

# Garmin G3X Touch

Electronic Flight Instrument System  
Part 23 AML STC Maintenance Manual  
Contains Instructions for Continued  
Airworthiness for STC SA01899WI



© Copyright 2019-2024  
Garmin Ltd. or its subsidiaries  
All Rights Reserved

Except as expressly provided herein, no part of this manual may be reproduced, copied, transmitted, disseminated, downloaded or stored in any storage medium, for any purpose without the express prior written consent of Garmin. Garmin hereby grants permission to download a single copy of this manual and of any revision to this manual onto a hard drive or other electronic storage medium to be viewed and to print one copy of this manual or of any revision hereto, provided that such electronic or printed copy of this manual or revision must contain the complete text of this copyright notice and provided further that any unauthorized commercial distribution of this manual or any revision hereto is strictly prohibited.

Garmin International, Inc.  
1200 E. 151<sup>st</sup> Street  
Olathe, KS 66062 USA  
Telephone: 913-397-8200  
[www.garmin.com](http://www.garmin.com)

Garmin (Europe) Ltd.  
Liberty House  
Bulls Copse Road  
Hounslow Business Park  
Southampton, SO40 9RB, UK  
Phone: +44 (0) 23 8052 4000  
Fax: +44 (0) 23 8052 4004

Garmin Würzburg GmbH  
Beethovenstrasse 1a  
97080 Würzburg, Germany

Garmin AT, Inc.  
2345 Turner Rd., SE  
Salem, OR 97302 USA  
Telephone: 503.581.8101

**RECORD OF REVISIONS**

<b>Revision</b>	<b>Revision Date</b>	<b>Description</b>
1	03/15/2019	Initial release
2	4/05/2019	Added interface to GPS 175 / GNX 375, limitations for GTS 8XX and non-Garmin autopilots
3	12/20/2019	Added installation and interface to GTR 20/200B, GMA 245R and GAP 26. Added interface to GNC 355(A), CO detector and wig-wag light functions.
4	02/12/2020	Added GI 275 Standby, updated GDU configurations, software loading information, CAN bus troubleshooting, and navigator config tables
5	04/08/2021	New fuel quantity interface and configuration for resistive fuel probes and other minor changes
6	12/29/2021	Updated for Phase 3 Smart Glide Integration
7	05/31/2022	Added GPT pressure transducers and other minor clarifications and improvements.
8	04/21/2023	Added interface between G3X and GI275 standby, TCW IBBS, and configuration updates for new software v9.15 functions
9	10/10/2023	Added GEA 24B and new GMA 245R part numbers, interface to SureFly TACH2, and other clarifications and improvements.
10	09/18/2024	Added GEA 24B Mod 1, Garmin Restrictor fitting, interface to new UMA 50" MAP sensor, GTR 205 / GNC 215 configuration, and other clarifications and improvements.

**INFORMATION SUBJECT TO EXPORT CONTROL LAWS**

This document may contain information which is subject to the Export Administration Regulations ("EAR") issued by the United States Department of Commerce (15 CFR, Chapter VII Subchapter C) and which may not be exported, released or disclosed to foreign nationals inside or outside the United States without first obtaining an export license. A violation of the EAR may be subject to a penalty of up to 10 years imprisonment and a fine of up to \$1,000,000 under section 2410 of the Export Administration Act of the 1979. The preceding statement is required to be included on any and all reproductions in whole or in part of this manual.

The information on this document is subject to change without notice. For updates and supplemental information regarding the operation of Garmin products visit [www.fly.garmin.com](http://www.fly.garmin.com).

**SOFTWARE LICENSE AGREEMENT FOR GARMIN AVIATION PRODUCTS**

BY USING THE DEVICE, COMPONENT OR SYSTEM MANUFACTURED OR SOLD BY GARMIN (“THE GARMIN PRODUCT”), YOU AGREE TO BE BOUND BY THE TERMS AND CONDITIONS OF THE FOLLOWING SOFTWARE LICENSE AGREEMENT. PLEASE READ THIS AGREEMENT CAREFULLY.

Garmin Ltd. and its subsidiaries (“Garmin”) grants you a limited license to use the software embedded in the Garmin Product (the “Software”) in binary executable form in the normal operation of the Garmin Product. Title, ownership rights, and intellectual property rights in and to the Software remain with Garmin and/or its third-party providers. You acknowledge that the Software is the property of Garmin and/or its third-party providers and is protected under the United States of America copyright laws and international copyright treaties. You further acknowledge that the structure, organization, and code of the Software are valuable trade secrets of Garmin and/or its third-party providers. You agree not to reproduce, decompile, disassemble, modify, reverse assemble, reverse engineer, or reduce to human readable form the Software or any part thereof or create any derivative works based on the Software. You agree not to export or re-export the Software to any country in violation of the export control laws of the United States of America.

## **WARNING, CAUTION, and NOTE DEFINITIONS**



### **WARNING**

*A warning is used to bring to the installer's immediate attention not only damage to the equipment, but personal injury may occur if the instruction is disregarded.*



### **CAUTION**

*A caution means damage to equipment is possible if procedural step is not followed.*



### **NOTE**

*A note provides additional information.*



### **WARNING**

*This product, its packaging, and its components contain chemicals known to the State of California to cause cancer, birth defects, or reproductive harm. This Notice is being provided in accordance with California's Proposition 65. If you have any questions or would like additional information, please refer to our web site at [www.garmin.com/prop65](http://www.garmin.com/prop65).*



### **WARNING**

*Perchlorate Material – special handling may apply. Refer to [www.dtsc.ca.gov/hazardouswaste/perchlorate](http://www.dtsc.ca.gov/hazardouswaste/perchlorate).*



### **WARNING**

*Failure to properly configure the EIS gauges per the POH/AFM and other approved data could result in serious injury, damage to equipment, or death.*



### **NOTE**

*All screen shots used in this document are current at the time of publication. Screen shots are intended to provide visual reference only. All information depicted in screen shots, including software file names, versions and part numbers, is subject to change and may not be up to date.*



### **NOTE**

*Ensure no dust or grit accumulates at the bottom of the display glass. The GDU 4X0 display uses invisible infrared beams for touch detection, this makes it very important to keep the screen clean, especially along the edges.*

**TABLE OF CONTENTS**

<b>SECTION</b>	<b>PAGE</b>
<b>1. INTRODUCTION</b>	<b>1</b>
1.1 Content, Scope, Purpose	1
1.2 Organization	2
1.3 Acronyms & Abbreviations	3
1.4 Publications	5
1.5 Revision and Distribution	5
<b>2. SYSTEM DESCRIPTION</b>	<b>6</b>
2.1 Equipment Descriptions	8
2.2 G3X Optional Interfaces	17
2.3 G3X Touch Architecture Example	18
2.4 Electrical Power Distribution	22
<b>3. G3X CONTROL &amp; OPERATION</b>	<b>23</b>
3.1 GDU 4X0 Softkeys/Features and Control	23
3.2 Display Modes	24
<b>4. INSTRUCTIONS FOR CONTINUED AIRWORTHINESS</b>	<b>31</b>
4.1 Airworthiness Limitations	31
4.2 Servicing Information	32
4.3 Maintenance Intervals	32
4.4 Visual Inspection	35
4.5 Electrical Bonding Test	35
4.6 GSU 25D Earth Magnetic Field Updates	36
4.7 Special Inspection Requirements	36
4.8 Pneumatic Line Drain Check (If installed)	37
<b>5. TROUBLESHOOTING</b>	<b>38</b>
5.1 General Troubleshooting	38
5.2 CAN Bus Network Troubleshooting	39
5.3 GDU 4X0	42
5.4 GSU 25D ADAHRS and GMU 11 Magnetometer Troubleshooting	44
5.5 Engine Indication Troubleshooting	52
5.6 Traffic Alert Messages	54
5.7 Transponder Alert Messages	54
5.8 Loss of Navigation Information (External Navigators)	55
5.9 Garmin GFC 500 Failure Messages	55
5.10 Loss of Non-Garmin Autopilot Heading and/or Course Datum	55
5.11 Miscellaneous Alerts	56
5.12 Aircraft Harness/LRU Connectors	56
<b>6. G3X EQUIPMENT REMOVAL &amp; REINSTALLATION</b>	<b>74</b>
6.1 GDU 4X0	74
6.2 GSU 25D ADAHRS	77
6.3 GMU 11 Magnetometer	79
6.4 GTP 59 Temperature Probe	79
6.5 GAD 27 Electronic Adapter Unit	80

6.6	GEA 24(B) Engine Indicating System .....	81
6.7	GAD 29B/29D ARINC 429 Adapter .....	88
6.8	GDL 5XR Datalink.....	89
6.9	GPS Antenna (P/N 011-04036-00 or 011-04036-10) .....	90
6.10	GTR 20 Remote-Mount VHF COM .....	92
6.11	GTR 200B VHF COM Radio .....	93
6.12	GMA 245R w/Marker Beacon Audio Panel.....	93
6.13	GAP 26 AOA Probe .....	94
6.14	EIS Annunciator Lights.....	96
<b>7.</b>	<b>G3X EQUIPMENT CONFIGURATION &amp; TESTING .....</b>	<b>98</b>
7.1	GDU 4X0 .....	98
7.2	GSU 25D ADAHRS and GMU 11 Magnetometer .....	98
7.3	GMU 11 Magnetometer.....	106
7.4	GTP 59 Temperature Probe .....	106
7.5	GAD 27.....	106
7.6	GEA 24(B) Engine and Airframe Unit .....	107
7.7	GAD 29B/29D .....	107
7.8	GDL 5XR.....	107
7.9	GTR 20 Remote-Mount VHF COM .....	108
7.10	GTR 200B VHF COM.....	108
7.11	GMA 245R Audio Panel.....	108
7.12	GAP 26 AOA Probe .....	108
7.13	G3X Software Information.....	109
7.14	Activation of GDL 51R/52R SiriusXM Radio and Weather .....	114
<b>8.</b>	<b>SYSTEM RETURN TO SERVICE PROCEDURE .....</b>	<b>115</b>
8.1	Recommended Test Equipment .....	115
8.2	Transponder Check.....	116
8.3	GPS Receiver Check .....	116
8.4	NAV Receiver Check .....	118
8.5	Audio Panel Interface Check .....	119
8.6	ADS-B Traffic Interface Check.....	121
8.7	TIS-A Traffic Interface Check.....	121
8.8	WX-500 Stormscope Interface Check.....	122
8.9	FIS-B Weather via ADS-B In.....	122
8.10	GDL 51R/52R SXM Weather Check.....	123
8.11	GDL 51R/52R SXM Audio Interface Check .....	123
8.12	EIS Check .....	123
8.13	ADAHRS and Magnetometer Ground Checks.....	126
8.14	GTR 20/200B Ground Checks .....	128
8.15	Garmin GFC 500 Autopilot.....	130
8.16	Non-Garmin Autopilot Interface .....	130
8.17	G5 Miscompare Check.....	133
8.18	GI 275 Miscompare Check .....	133
8.19	GAP 26 AOA Probe Checks .....	134

8.20 Wig-Wag Landing/Taxi Light Check (if configured) .....	135
8.21 CO Detector Display Check (if configured) .....	135
8.22 Weight and Balance (W&B) Update (as required) .....	135
8.23 EMI / RFI Check .....	136
<b>APPENDIX A            INSTALLATION SPECIFIC INFORMATION .....</b>	<b>A-1</b>
A.1 Maintenance Records .....	A-1
A.2 Equipment Locations.....	A-3
A.3 Wire Routing .....	A-3
A.4 Configuration File .....	A-5
<b>APPENDIX B            EXTERNAL INTERFACE CONFIGURATION .....</b>	<b>B-1</b>
B.1 GPS/VHF Nav Interfaces .....	B-1
B.2 GPS NAV Interface .....	B-5
B.3 VHF NAV/COM Interface .....	B-7
B.4 Traffic and Weather Source .....	B-8
B.5 Non-Garmin Autopilot Systems.....	B-11
B.6 Audio Panel.....	B-14
B.7 EIS Sensors .....	B-15
B.8 Antennas .....	B-19
B.9 ADS-B Antenna Interface.....	B-20
B.10 COM Antenna Interface .....	B-20
B.11 Marker Beacon Antenna Interface .....	B-21

**LIST OF ILLUSTRATIONS**

<b>FIGURE</b>	<b>PAGE</b>
Figure 2-1 – GDU 460 (Single PFD, with EIS Optional) .....	9
Figure 2-2 – GDU 470 (PFD) .....	10
Figure 2-3 – GSU 25D ADAHRS .....	11
Figure 2-4 – GMU 11 Magnetometer .....	11
Figure 2-5 – GTP 59 .....	12
Figure 2-6 – GAD 29B/29D (ARINC 429 Adapter) .....	12
Figure 2-7 – GAD 27 .....	13
Figure 2-8 – GEA 24(B) Engine and Airframe Unit.....	13
Figure 2-9 – GDL 52R Data Link .....	15
Figure 2-10 – GPS Antenna (011-04036-10 Shown).....	15
Figure 2-11 – GAP 26 AOA Probe .....	16
Figure 2-12 – GTR 20 COM Radio .....	16
Figure 2-13 – GTR 200B COM Radio.....	17
Figure 2-14 – GMA 245R Audio Panel .....	17
Figure 2-15 – Example G3X Architecture .....	18
Figure 2-16 – Example G3X Architecture – Standalone MFD .....	20
Figure 3-1 – GDU Features and Controls .....	24
Figure 3-2 – Split/Full Format Buttons - GDU 460.....	25
Figure 3-3 – Split/Full Format Buttons - GDU 470.....	25
Figure 3-4 – Normal Mode, Full Format – PFD w/ EIS (Example).....	25



Figure 3-5 – Normal Mode, Split Format – PFD W/ EIS (Example).....	26
Figure 3-6 – Normal Mode, Full – MFD with EIS (Example).....	27
Figure 3-7 – GDU Knob Function Example .....	28
Figure 3-8 – Data Entry Options (Examples).....	28
Figure 3-9 – Configuration Mode Pages .....	29
Figure 5-1 – Incorrect CAN Bus Topographies.....	40
Figure 5-2 – Correct CAN Bus Wiring Example and Node Connections .....	40
Figure 5-3 – Network Error Rate (Configuration/Diagnostic Mode).....	41
Figure 5-4 – Heading Failure Indication.....	46
Figure 5-5 – Attitude Failure Indication .....	47
Figure 5-6 – Magnetometer Interference Test On-screen Instructions.....	49
Figure 5-7 – Magnetometer Interference Test Progress.....	50
Figure 5-8 – Magnetometer Interference Test Status.....	50
Figure 5-9 – Engine/Airframe Failure Indications.....	52
Figure 5-10 – View of P4X01 Connector from back of GDU .....	57
Figure 5-11 – View of P4X02 Connector from back of GDU .....	57
Figure 5-12 – View of J251 Connector on the GSU 25D .....	59
Figure 5-13 – View of J252 Connector on the GSU 25D.....	59
Figure 5-14 – View of J111 Connector on the GMU 11 .....	60
Figure 5-15 – View of J271 Connector on the GAD 27 .....	61
Figure 5-16 – View of TB273 Terminal Block on GAD 27 .....	63
Figure 5-17 – View of J241 Connector on the GEA 24(B).....	63
Figure 5-18 – View of J242 Connector on the GEA 24(B).....	64
Figure 5-19 – View of J243Connector on the GEA 24(B).....	65
Figure 5-20 – View of J244 Connector on the GEA 24(B).....	66
Figure 5-21 – View of J291 Connector on the GAD 29B/29D .....	67
Figure 5-22 – View of J292 Connector on the GAD 29B/29D .....	68
Figure 5-23 – View of J5X1 Connector on the GDL 5XR .....	69
Figure 5-24 – View of J2001 Connector on GTR 20 or GTR 200B .....	69
Figure 5-25 – View of J2401 Connector on GMA 245R .....	70
Figure 5-26 – View of J2402 Connector on GMA 245R .....	72
Figure 6-1 – GDU 460 Shown, (GDU 470 Similar) .....	75
Figure 6-2 – Configuration Module (PFD).....	76
Figure 6-3 – GDU 460-Mounted GSU 25D (GDU 470 similar).....	77
Figure 6-4 – Remote mounted GSU 25D.....	78
Figure 6-5 – GMU 11 Magnetometer .....	79
Figure 6-6 – GTP 59 Temperature Probe .....	80
Figure 6-7 – GAD 27 .....	81
Figure 6-8 – GEA 24(B) .....	82
Figure 6-9 – Brass Pressure Sensor (Coupling Mount Example).....	84
Figure 6-10 – GPT Pressure Sensor (Housing & Coupling Mount Examples).....	85
Figure 6-11 – Carburetor Air Temperature Sensor Mounting.....	87
Figure 6-12 – Fuel Flow Transducer Installation Example .....	88
Figure 6-13 – GAD 29B/29D.....	89

Figure 6-14 – GDL 5XR (GDL 52R Shown).....	90
Figure 6-15 – GPS Antenna (Screw-mounted Installation Example) .....	91
Figure 6-16 – GPS Antenna (Hook and Loop Installation Example) .....	92
Figure 6-17 – GTR 20 VHF COM Radio .....	93
Figure 6-18 – GMA 245R Audio Panel .....	94
Figure 6-19 – GAP 26 Mechanical Splice Detail (14-volt Aircraft with 10 AWG Wire) .....	95
Figure 6-20 – GAP 26 AOA Probe Assembly .....	96
Figure 7-1 – Aircraft Level Attitude .....	100
Figure 7-2 – Pitch/Roll Offset Calibration in Progress .....	101
Figure 7-3 – Pitch/Roll Offset Completion Status .....	101
Figure 7-4 – Compass Rose Starting Position.....	102
Figure 7-5 – Magnetometer Calibration On-Screen Instructions .....	103
Figure 7-6 – Magnetometer Calibration Progress.....	103
Figure 7-7 – Static Pressure Calibration .....	104
Figure 7-8 – Static Pressure Calibration Warning.....	104
Figure 7-9 – Static Pressure Calibration Instructions .....	105
Figure 7-10 – Static Pressure Calibration in Progress.....	105
Figure 7-11 – Static Pressure Calibration Completion Status .....	105
Figure 7-12 – Update Software Window (Example) .....	112
Figure 7-13 – Data Link Page .....	114
Figure 8-1 – Transponder Setup Page (Normal Mode) .....	116
Figure 8-2 – Lightning Tab.....	122
Figure A-1– Generic Aircraft Figure .....	A-4

**LIST OF TABLES**

<b><u>TABLE</u></b>	<b><u>PAGE</u></b>
Table 1-1 – Required Documents .....	5
Table 2-1 – G3X Touch AML STC Installed Sensors .....	14
Table 2-2 – GDL 5XR Data Link Features and Functions .....	14
Table 2-3 – G3X Touch and Supporting Equipment.....	22
Table 2-4 – LRU Current Draw .....	22
Table 3-1 – LRU Status Indicator Symbols.....	29
Table 4-1 – Maintenance Intervals.....	33
Table 4-2 – Electrical Bonding Procedure .....	36
Table 5-1 – Status LED Indications .....	39
Table 5-2 – LED Indications Recommended Action .....	39
Table 5-3 – CAN Network Error Values (Configuration/Diagnostic Mode) .....	41
Table 5-4 – Unit Communication Error Messages (Dual GDU Installations).....	43
Table 5-5 – GDU Reboot During Engine Start.....	44
Table 5-6 – ADAHRS and Magnetometer Troubleshooting.....	45
Table 5-7 – Magnetometer Interference Test Sequence Example .....	51
Table 5-8 – EIS Gauges Troubleshooting.....	52
Table 5-9 – Traffic Alert Troubleshooting.....	54
Table 5-10 – Transponder Alert Troubleshooting .....	54

Table 5-11 – Loss of Navigation Information (External Navigators) .....	55
Table 5-12 – Miscellaneous Alerts .....	56
Table 5-13 – P4X01/J4X01 Pin Functions .....	57
Table 5-14 – P4X02/J4X02 Pin Functions .....	58
Table 5-15 – P251/J251 Pin Functions .....	59
Table 5-16 – P252/J252 Pin Functions .....	60
Table 5-17 – P111/J111 Pin Functions .....	60
Table 5-18 – GTP 59 Lead Wire Functions .....	61
Table 5-19 – P271/J271 Pin Functions .....	61
Table 5-20 – TB273 Terminal Functions .....	63
Table 5-21 – P241/J241 Pin Functions .....	63
Table 5-22 – P242/J242 Pin Functions .....	64
Table 5-23 – P243/J243 Pin Functions .....	65
Table 5-24 – P244/J244 Pin Functions .....	66
Table 5-25 – P291/J291 Pin Functions .....	67
Table 5-26 – P292/J292 Pin Functions .....	68
Table 5-27 – P5X1/J5X1 Pin Functions .....	69
Table 5-28 – P2001/J2001 Pin Functions .....	69
Table 5-29 – P2401/J2401 Pin Functions .....	71
Table 5-30 – P2402/J2402 Pin Functions .....	72
Table 5-31 – GMA 245R DIP Switch Configuration Settings .....	73
Table 6-1 – GDU Configuration Module Kit (P/N 010-12253-01) .....	76
Table 7-1 – GSU 25D/GMU 11 Recalibration Criteria .....	100
Table 8-1 – LRU Status Indicators .....	115
Table 8-2 – Airspeed Test Points .....	127
Table 8-3 – Heading Verification – ADAHRS Check .....	128
Table 8-4 – EMI Victim/Source Matrix .....	137
Table A-1 – G3X Post-Installation Log .....	A-2
Table A-2 – G3X Equipment Locations .....	A-3
Table B-1 – Compatible Equipment – GPS/VHF Nav Interfaces .....	B-1
Table B-2 – Compatible Equipment – GPS NAV .....	B-5
Table B-3 – Compatible Equipment – VHF NAV/COM .....	B-7
Table B-4 – Compatible Traffic and Weather Sources .....	B-8
Table B-5 – Compatible Equipment – Non-Garmin Autopilots .....	B-11
Table B-6 – Compatible Equipment – Audio Panel .....	B-14
Table B-7 – Compatible EIS Sensors .....	B-15
Table B-8 – Supported GPS & SXM Antennas .....	B-19
Table B-9 – GPS or GPS/WAAS Antenna Minimum Requirements .....	B-20
Table B-10 – SXM Satellite Radio Antenna Minimum Requirements .....	B-20

## 1. INTRODUCTION

### 1.1 Content, Scope, Purpose

This document provides Instructions for Continued Airworthiness (ICA) for the Garmin G3X Touch EFIS Part 23 AML STC as installed in Part 23 aircraft under Supplemental Type Certificate (STC) SA01899WI.

This document satisfies the requirements for continued airworthiness as defined by 14 CFR Part 23.1529 Appendix G. Information in this document is required to maintain the continued airworthiness of the G3X Touch EFIS systems.

#### 1.1.1 Applicability

This document applies to all aircraft with the G3X Touch system installed in accordance with AML STC SA01899WI.

Modification of an aircraft by this STC obligates the aircraft operator to include the maintenance information provided by this document in the operator's Aircraft Maintenance Manual and the operator's Aircraft Scheduled Maintenance Program.

## 1.2 Organization

This manual is structured as described below:

### Section 2: System Description

Provides an overview of the G3X Touch EFIS system equipment installed by this STC.

### Section 3: Control & Operation

Presents basic control and operation information specifically tailored to maintenance practices. Basic G3X Touch Configuration Mode operation is also described.

### Section 4: Instructions for Continued Airworthiness

Provides maintenance instructions for Continued Airworthiness of the G3X Touch EFIS system.

### Section 5: Troubleshooting

Provides troubleshooting information to aid in diagnosing and resolving potential problems with equipment and functions installed by this STC.

### Section 6: G3X Equipment Removal & Replacement

Gives instructions for the removal and replacement of G3X Touch EFIS equipment.

### Section 7: G3X Equipment Configuration & Testing

Gives instructions for loading software, configuring, and testing of G3X Touch EFIS equipment.

### Section 8: System Return to Service Procedure

Specifies return-to-service (checkout) procedures to be performed upon completion of maintenance of the G3X Touch EFIS system.

### Appendix A: Installation Specific Information

Provides a template to record aircraft-specific installation and configuration data for the G3X Touch EFIS system.

### 1.3 Acronyms & Abbreviations

<b>AC:</b>	Advisory Circular	<b>GFC:</b>	Garmin Automatic Flight Control System
<b>ADAHRS:</b>	Air data, Attitude and Heading Reference System.	<b>GMU:</b>	Garmin Magnetometer Unit
<b>ADI:</b>	Attitude Direction Indicator	<b>GNS:</b>	Garmin Navigation System
<b>ADS-B:</b>	Automatic Dependent Surveillance - Broadcast	<b>GNX:</b>	Garmin Navigator Transponder
<b>ADS-R:</b>	Automatic Dependent Surveillance - Rebroadcast	<b>GPS:</b>	Global Positioning System
<b>AFCS:</b>	Aircraft Flight Control System	<b>GPSS:</b>	GPS Roll Steering
<b>AFM:</b>	Airplane Flight Manual	<b>GSU:</b>	Garmin Sensor Unit
<b>AHRS:</b>	Attitude and Heading Reference System	<b>GTN:</b>	Garmin Touch Navigator
<b>ALT:</b>	Altitude Preselect	<b>GTP:</b>	Garmin Temperature Probe
<b>AML:</b>	Approved Model List	<b>GTR:</b>	Garmin Transmitter / Receiver
<b>AND:</b>	Logical AND	<b>GTS:</b>	Garmin Traffic System
<b>AOA:</b>	Angle of Attack	<b>GTX:</b>	Garmin Transponder
<b>ARINC:</b>	Aeronautical Radio, Incorporated	<b>HDG:</b>	Heading (mode)
<b>AS:</b>	Aerospace Standard	<b>HSDB:</b>	High Speed Data Bus
<b>ASI:</b>	Airspeed Indicator	<b>HSI:</b>	Horizontal Situation Indicator
<b>AWG:</b>	American Wire Gauge	<b>IAS:</b>	Indicated Air Speed
<b>BNC:</b>	Bayonet Neill-Concelman	<b>ICA:</b>	Instructions for Continued Airworthiness
<b>CAN:</b>	Controller Area Network	<b>ID:</b>	Identifier
<b>CDI:</b>	Course Deviation Indicator	<b>IFR:</b>	Instrument Flight Rules
<b>CDU:</b>	Control Display Unit	<b>IGRF:</b>	International Geomagnetic Reference Field
<b>CE:</b>	European Committee	<b>ILS:</b>	Instrument Landing System
<b>CFR:</b>	Code of Federal Regulations	<b>KTS:</b>	Knots
<b>CHT:</b>	Chart Processing	<b>LCD:</b>	Liquid Crystal display
<b>CI:</b>	Course to Intercept	<b>LED:</b>	Light Emitting Diode
<b>COM:</b>	Communication Radio	<b>LNAV:</b>	Lateral Navigation
<b>CRS:</b>	Course	<b>LOC:</b>	Localizer
<b>CS:</b>	Conducted Susceptibility	<b>LRU:</b>	Line-Replaceable Unit
<b>DC:</b>	Direct Current	<b>METAR:</b>	Meteorological Terminal Aviation Routine Weather Report
<b>DDM:</b>	Difference in Depth of Modulation	<b>MFD:</b>	Multi-Function Display
<b>DME:</b>	Distance Measuring Equipment	<b>MFR:</b>	Manufacturer
<b>DMM:</b>	Digital Multi Meter	<b>NEXRAD:</b>	Next-Generation Radar
<b>ECO:</b>	Engineering Change Order	<b>NMEA:</b>	National Marine Electronics Association
<b>EEPROM:</b>	Electrically Erasable Programmable Read-Only Memory	<b>OAT:</b>	Outside Air Temperature
<b>EFIS:</b>	Electronic Flight Instrument System	<b>OBS:</b>	Omni Bearing Selector
<b>EGT:</b>	Exhaust Gas Temperature	<b>OR:</b>	Logical OR
<b>EIS:</b>	Engine Indication System	<b>PFD:</b>	Primary Flight Display
<b>EMC:</b>	Electromagnetic Compatibility	<b>POH:</b>	Pilot's Operating Handbook
<b>EMI:</b>	ElectroMagnetic Interference	<b>RPM:</b>	Revolutions per Minute
<b>ES:</b>	Extended Squitter	<b>RTCA:</b>	Radio Technical Commission for Aeronautics
<b>FAA:</b>	Federal Aviation Administration	<b>RX:</b>	Receive
<b>FF:</b>	Fuel Flow	<b>SAS:</b>	Stability Augmentation System
<b>FIS-B:</b>	Flight Information Service Broadcast	<b>SD:</b>	SanDisk Memory
<b>GA:</b>	Go-Around	<b>STC:</b>	Supplemental Type Certificate
<b>GAD:</b>	Garmin Adapter	<b>SXM:</b>	Sirius XM
<b>GDL:</b>	Garmin Datalink LRU	<b>SYS:</b>	System
<b>GDU:</b>	Garmin Display Unit	<b>TAS:</b>	Traffic Advisory System
<b>GEA:</b>	Garmin Engine and Airframe Unit		OR True Airspeed

<b>TAWS:</b>	Terrain Awareness and Warning System	<b>UHF:</b>	Ultra High Frequency
<b>TCAS:</b>	Traffic Collision Avoidance System	<b>VDC:</b>	Volts of Direct Current
<b>TIS:</b>	Traffic Information Service	<b>VFR:</b>	Visual Flight Rules
<b>TIS-A:</b>	Traffic Information Service-A	<b>VHF:</b>	Very High Frequency
<b>TIS-B:</b>	Traffic Information Service - Broadcast	<b>VLOC:</b>	VOR/Localizer
<b>TIT:</b>	Turbine Inlet Temperature	<b>VNAV:</b>	Vertical Navigation
<b>TNC:</b>	Threaded Neill-Concelman	<b>VOR:</b>	VHF Omni Directional Radio Range
<b>TSO:</b>	Technical Standard Order	<b>WAAS:</b>	Wide Area Augmentation System
<b>TX:</b>	Transmit	<b>WPT:</b>	Waypoint
<b>UAT:</b>	Universal Access Transceiver	<b>XM:</b>	XM Satellite Radio

## 1.4 Publications

The following documents are required by this maintenance manual to perform maintenance. It is the responsibility of the owner / operator to ensure latest versions of these documents are used during operation, servicing or maintenance of the airplane.

**Table 1-1 – Required Documents**

Document Number	Garmin Document Title
190-02472-00	Garmin G3X Pilot's Guide for Certified Aircraft
190-02472-01	Garmin G3X Touch EFIS Part 23 AML STC Installation Manual

## 1.5 Revision and Distribution

This document is required for maintaining the continued airworthiness of the aircraft. When this document is revised, each page will also be revised to indicate the current revision level.

Garmin Dealers may obtain the latest revision of this document on the Garmin Dealer Resource Center website.

Owners/operators may obtain the latest revision of this document by one of the following methods:

- Visit <https://fly.garmin.com/support>
- Contact a Garmin dealer
- Contact Garmin Product Support at 913-397-8200, toll free 866-739-5687



## 2. SYSTEM DESCRIPTION

This section provides an overview of the line replaceable units (LRUs) installed by the G3X Touch EFIS Part 23 AML STC.

The Garmin G3X Touch EFIS replaces the standard pneumatic instruments (altimeter, airspeed indicator (ASI) and vacuum attitude gyro indicator) and combines primary flight instrumentation, aircraft systems instrumentation, and navigational information, all displayed on up to four color Garmin Display Units (GDU) 4X0. The following functionalities can be provided by the G3X Touch EFIS system:

- Multi-Function Display (MFD)
- Optional Primary Flight Display (PFD)
- Optional Engine Indicating System (EIS)
- Optional Traffic and Weather Receiver (ADS-B In)
- Optional SiriusXM Weather and Radio (subscription required)
- Optional Angle of Attack (AOA)
- Optional VHF COM (panel or remote mount)
- Optional Audio Panel (remote mount)
- Optional Landing and Taxi Light Wig-Wag

A G3X system installed per this STC may consist of one of the following display configurations for the Pilot-in-Command:

1. Single GDU 4X0 installed as a standalone MFD with no PFD no GSU 25D present, and optional EIS supported.
2. Single 7-inch GDU 470 (portrait orientation) PFD with the capability to be split into a PFD/MFD configuration but with no support for EIS.
3. Single 10.6-inch GDU 460 with PFD/MFD split capability and EIS supported.
4. Dual 7-inch GDU 470 (portrait orientation), one configured as PFD and the other as MFD, with EIS only supported on the MFD.
5. Single 7-inch GDU 470 (portrait orientation) as PFD and a single 10.6-inch GDU 460 as MFD with the EIS only supported on 10.6-inch MFD.
6. Single 10.6-inch GDU 460 as PFD and a single 7-inch GDU 470 (portrait orientation) as MFD, with the EIS supported in either the PFD or MFD.
7. Dual 10.6-inch GDU 460, one configured as PFD and the other as MFD, with EIS supported on either the PFD or MFD.

Additional displays for the Copilot may be installed on the right side of the panel in a side-by-side cockpit or second cockpit in a tandem aircraft. A maximum of three GDUs can be installed in a side-by-side aircraft and four GDUs in a tandem aircraft.

When at least two GDUs are installed, one as PFD and the other as an MFD, failure of one display unit will cause the system to automatically revert to a reversionary format. In the reversionary format, primary flight information, radio tuning information and EIS (if installed) are displayed on the remaining GDU. Additionally, a multi-function pane can be displayed if the “split” touchscreen button is selected.

Each of the above display configurations require the following LRUs and equipment as part of the installation:

- GSU 25D Air Data Computer, Aircraft Heading and Reference System (ADAHRS) (required for PFD)
- GMU 11 Magnetometer (required for PFD)
- GTP 59 Temperature Probe (required for PFD)
- GPS Antenna (required by all display configurations)

- GAD 27 Electronic Adaptor Unit (required for 14-volt aircraft with EIS unless a TCW IBBS is connected to the GDU, GSU 25D, and GEA 24(B) per AML STC #SA04400NY)

The GAD 27 Electronic Adapter Unit can provide stabilized power output during low voltage events and is required for 14-volt aircraft with EIS unless a TCW IBBS is connected to the GDU, GSU 25D, and GEA 24(B) per AML STC #SA04400NY. The GAD 27 may optionally be installed on both 14 and 28 -volt aircraft to provide the ability to flash the landing and/or taxi lights in an alternating fashion, otherwise known as “Wig Wag”.

Standby attitude, airspeed, and altitude instruments are required if a G3X display unit is installed as the primary flight display (PFD) in IFR installations. The standby instruments may be a Garmin G5, GI 275, or existing pneumatic instruments. IFR installations which include Copilot displays must use the G5 or GI 275.

The G3X system is composed of several sub-units or Line Replaceable Units (LRUs). The LRUs have a modular design and can be installed directly behind the instrument panel or mounted directly on the panel in the case of a GDU, or in a separate location. Each LRU has a particular function, or set of functions, as described in their applicable sections.

A GPS antenna is required for G3X installations. The GDU contains an internal WAAS GPS receiver which supports VFR navigation only. IFR navigation requires a compatible certified navigator that can interface to the G3X system and display flight plan and guidance on the GDU. Alternatively, navigation equipment that is not compatible with G3X can retain their separate external indicator to maintain IFR capability. The external indicator installation is outside the scope of this STC.

G3X systems using optional SiriusXM (SXM) or ADS-B receivers require dedicated antennas which are not installed under this STC.

### **Standalone MFD Installation**

The G3X Touch AML STC approves the installation of either a GDU 470 or 460 as a standalone MFD (no PFD and no GSU 25D installed). Compared to fully featured G3X Touch system where an MFD is installed with a PFD, the standalone MFD supports most of the same MFD functions and interfaces including:

- Moving map, charts, terrain, VFR flight planning, and EIS
- Weather and traffic from GDL 5XR, GTX 345(R), GNX 375, GTS 8XX
- Interface to Garmin COM & NAV radios with frequency tuning and display
- Control and display of GTR 20 and GMA 245R
- Analog audio output of G3X aural alerts including altitude, terrain, traffic, GFC 500, and EIS
- Interface to external Garmin GPS navigators with ability to select between display of internal VFR flight plan or external navigator flight plan
- Interface to one or two G5s which can display lateral and vertical deviation from the MFD’s built-in VFR navigation and VNAV functions
- Interface to the GFC 500 autopilot (requires a G5) which allows the autopilot to follow the MFD’s built-in VFR flight plan and VNAV descent profile
- Interface to the non-Garmin autopilots approved under this STC (requires a G5 and GAD 29B/29D) which allows the autopilot to follow the MFD’s built-in VFR flight plan using GPSS mode on the G5
- Interface to a GAD 13 OAT (when installed with a G5 ADI) which supports the Glide Range Ring function on the MFD
- Interface to a GMU 11 (when installed with a G5) which allows the MFD to send heading data to WX-500 lightning detector or GTS 8XX traffic systems
- Interface to GAD 27 (optional for wig-wag function; required for 14v installations with EIS unless a TCW IBBS is connected to the GDU and GEA 24(B) per AML STC #SA04400NY)

The standalone MFD does not support altitude encoder function or remote control of any transponder.

## 2.1 Equipment Descriptions

### 2.1.1 GDU 460

The Garmin Display Unit (GDU) 460 provides a central display and user interface for the G3X Touch EFIS Touch system. GDU 460 is a 10.6-inch landscape-oriented, panel mounted control and display unit with a GPS receiver. The GDU features a high-resolution infrared touchscreen user interface augmented by a set of dual-concentric knobs and dedicated buttons for commonly used functions. The GDU 460 is mounted flush to the aircraft instrument panel. Below is a list of some of the functions provided by the GDU 460.

Many of the listed functions depend on optional equipment interfaces and/or subscription services.

#### *PFD Functions*

- Primary attitude, heading, and air data information
- Slip/skid and rate-of-turn indication
- Synthetic Vision including Pathways and Flight Path Marker
- Horizontal Situation Indicator (HSI)
- Flight Director display with GFC500 autopilot modes and alerts
- Clock and timer

#### *MFD Functions*

- Moving map with VFR flight planning function
- Charts and SafeTaxi
- Traffic display and alerting
- Terrain and obstacle display and alerting
- Datalink weather
- Display of flight plan and navigation from an external Garmin GPS navigator
- Display of navigation from an external VOR/ILS NAV radio
- Control and display of Transponder (not supported in Standalone MFD)
- Control and display of COM and NAV radios

#### *System Interfaces*

- Display engine parameters when configured and interfaced with a Garmin Engine Adapter, GEA 24(B).
- Wireless Bluetooth transceiver that can communicate with tablet computers and other Garmin devices that support Connex interface protocol. Refer to *G3X Touch Pilot's Guide for Certified Aircraft* (190-02472-00) for guidance in using Connex Bluetooth connections.
- CAN and RS-232 interfaces to communicate with Garmin LRUs and other devices. Refer to the appropriate sections in *G3X Touch EFIS Part 23 AML STC Installation Manual* (190-02472-01) for interconnect and configuration information.
- BNC connector for GPS antenna interface.

The GDU 460 may be installed in various configurations as described in Section 2 (System Description). Figure 2-1 example shows a GDU 460 installed as PFD/MFD split functionality with EIS supported.



Figure 2-1 – GDU 460 (Single PFD, with EIS Optional)

## 2.1.2 GDU 470

The Garmin Display Unit (GDU) 470 provides a central display and user interface for the G3X Touch EFIS Touch system. The Garmin Display Unit (GDU) 470 is a 7-inch LCD portrait-oriented panel mounted control and display unit with a GPS receiver. The GDU features a high-resolution infrared touchscreen user interface augmented by a set of dual-concentric knobs and dedicated buttons for commonly used functions. The GDU 470 is mounted flush to the aircraft instrument panel. Below is a list of some of the functions provided by the GDU 470.

Many of the listed functions depend on optional equipment interfaces and/or subscription services.

### *PFD Functions*

- Primary attitude, heading, and air data information
- Slip/skid and rate-of-turn indication
- Synthetic Vision including Pathways and Flight Path Marker
- Horizontal Situation Indicator (HSI)
- Flight Director display with GFC500 autopilot modes and alerts
- Clock and timer

### *MFD Functions*

- Moving map with VFR flight planning function
- Charts and SafeTaxi
- Traffic display and alerting
- Terrain and obstacle display and alerting
- Datalink weather
- Display of flight plan and navigation from an external Garmin GPS navigator
- Display of navigation from an external VOR/ILS NAV radio
- Control and display of Transponder (not supported in Standalone MFD)

- Control and display of COM and NAV radios

*System Interfaces*

- Display engine parameters when configured and interfaced with a Garmin Engine Adapter, GEA 24(B).
- Wireless Bluetooth transceiver that can communicate with tablet computers and other Garmin devices that support Connex interface protocol. Refer to *G3X Touch Pilot's Guide for Certified Aircraft* (190-02472-00) for guidance in using Connex Bluetooth connections.
- CAN and RS-232 interfaces to communicate with Garmin LRUs and other devices. Refer to the appropriate sections in the *G3X Touch EFIS Part 23 AML STC Installation Manual* (190-02472-01) for interconnect and configuration information.
- BNC connector for GPS antenna interface.

The GDU 470 may be installed in various configurations as described in Section 2 (System Description). Figure 2-2 example shows a GDU 470 installed as a PFD. EIS is only supported on a GDU 470 when configured as an MFD.

The display on a 7" GDU when configured as an MFD (in a multiple display configuration) does not have split format functionality in normal mode but is available in reversionary mode if the PFD fails.



**NOTE**

*EIS is not supported in a single GDU 470 installation.*



**Figure 2-2 – GDU 470 (PFD)**

### 2.1.3 GSU 25D ADAHRS

The GSU 25D is an LRU that provides Air Data Computer and Attitude Heading Reference System (ADAHRS) information. The GSU 25D interfaces to a remote mounted GMU 11 magnetometer for heading information, and computes OAT and TAS from inputs provided by the GTP 59. The GSU 25D is connected to existing primary pitot/static system. Only one GSU 25D is approved for installation and interface by this STC.

When a GAP 26 probe is installed, the GSU 25D also computes AOA from inputs provided by the GAP 26 as well as the aircraft's pitot/static system, and is subsequently displayed by the G3X PFD.



**Figure 2-3 – GSU 25D ADAHRS**

### 2.1.4 GMU 11 Magnetometer

The Garmin GMU 11 Magnetometer is a remote mounted device that provides magnetic field measurements to the GSU 25D to support computation of flight attitude and heading data.



**Figure 2-4 – GMU 11 Magnetometer**

### 2.1.5 GTP 59 Temperature Probe

The Garmin GTP 59 is an externally mounted temperature probe that provides raw outside air temperature data. The device is a three-wire temperature probe interface.



**Figure 2-5 – GTP 59**

### **2.1.6 GAD 29B/29D ARINC 429 Adapter (Optional)**

The GAD 29B/29D allows the G3X system to interface to IFR GPS navigators such as the Garmin GPS 175, GNX 375, GNC 355(A), GNS and GTN series. It also allows for interface to some non-Garmin autopilots.



**Figure 2-6 – GAD 29B/29D (ARINC 429 Adapter)**

### **2.1.7 GAD 27 Electronic Adapter Unit**

The GAD 27 provides a stabilized 12V power output to keep EIS online during engine start when battery voltage drops. It is installed on airplanes with a 14-volt electrical system that install the G3X EIS option unless a TCW IBBS is connected to the GDU, GSU 25D, and GEA 24(B) per AML STC #SA04400NY. It may be installed on aircraft with a 14-volt electrical system that do not have EIS to prevent reboot during temporary low battery voltage levels. Refer to Appendix A.1 for installed equipment.

If a GAD 27 is not installed on 14-Volt aircraft and a PFD/MFD reboot is observed, troubleshoot the aircraft per guidance in Section 5.3.5.

The GAD 27 may optionally be installed on both 14 and 28-volt aircraft to provide the ability to flash the landing and/or taxi lights of the airplane in an alternating fashion, otherwise known as “Wig Wag”. This is the only approved GAD 27 function for 28-volt aircraft.



Figure 2-7 – GAD 27

### 2.1.8 GEA 24(B) Engine/Airframe Unit

The Garmin Engine and Airframe GEA 24(B) is an input/output system used to monitor and power engine and airframe sensors. The GEA 24(B) is used to monitor and display engine data for single engine aircraft with up to 6 cylinders.



Figure 2-8 – GEA 24(B) Engine and Airframe Unit



**NOTE**

*For most interfaces the GEA 24 and GEA 24B are interchangeable with the same wiring and configuration settings, however the GEA 24 interface to resistive fuel probes must use a pair of 2.2kΩ resistors and be configured as 'Voltage' interfaces (refer to Garmin SB 2134 and Installation Manual Rev.9 or later). If a GEA 24 is replaced by a GEA 24B, any fuel quantity interfaces to resistive probes must be recalibrated regardless of whether the 2.2kΩ resistors in the harness are retained or removed. For new installations with a GEA 24B, the resistors are not required, reference the STC Installation Manual Rev 14 (or later).*

#### 2.1.8.1 EIS Functionality

If a GEA 24(B) is installed, configured engine data and airframe parameters are displayed on the GDU. This manual only provides information for the EIS sensors that were installed by the *G3X Touch EFIS Part 23 AML STC*.

Table 2-1 lists the sensors that are maintained in this manual. Refer to the applicable maintenance data and/or TSO manual for other sensors that are interfaced to the EIS.



**Table 2-1 – G3X Touch AML STC Installed Sensors**

Function	Description	Garmin Part Number
<b>Oil Pressure</b>	Garmin 150 PSIG Pressure, Brass	011-04202-30
	Garmin GPT 150 PSIG Pressure, S.S.	011-05783-30
<b>Oil Temperature</b>	UMA T3B3-2.5G (K Type Probe)	494-70009-00
<b>Manifold Pressure</b>	Garmin 30 PSIA Pressure, Brass	011-04202-00
	Garmin GPT 30 PSIA Pressure, S.S.	011-05783-00
	Garmin Restrictor, AN3 to 1/8 MNPT	117-02083-00*
<b>Carb Air Temperature</b>	UMA T3B10-SG (K Type Probe)	494-70010-00
<b>Fuel Pressure</b>	Garmin 75 PSIG Pressure, Brass	011-04202-20
	Garmin GPT 75 PSIG Pressure, S.S.	011-05783-20
	Garmin 15 PSIG Pressure, Brass	011-04202-10
	Garmin GPT 15 PSIG Pressure, S.S.	011-05783-10
<b>Fuel Flow &amp; Return FF</b>	EI FT-60	494-10001-00
	EI FT-90	494-10001-01

\*The Garmin Restrictor may have been installed to reduce jitter on the manifold pressure gauge. It is similar to an AN816-3D fitting with 1/8-27 NPT and AN3-style threads except it features an orifice, silver color, and it is marked "R.016".

### 2.1.9 GDL 5XR Data Link

GDL 5XR provides the data and functions shown in Table 2-2 via Bluetooth® wireless technology and/or over wired connections.

Note: Approved software for PMA GDL 5XR units can only be loaded via the G3X GDU (reference Software Loading Procedure, Section 7.13). The ability to update GDL 5XR software via Bluetooth connections has been disabled for PMA GDL 5XR units.

**Table 2-2 – GDL 5XR Data Link Features and Functions**

GDL 50R	GDL 51R	GDL 52R
ADS-B Receiver (Traffic and Weather)	Sirius XM Receiver (Weather/audio)	ADS-B Receiver (Traffic and Weather) and Sirius XM Receiver (Weather/audio)

The GDL 5XR are remote mounted and require external antennas and power connections. No battery is provided.

The GDL 50R/52R receives Traffic (ADS-B/ADS-R and TIS-B) on both Universal Access Transceiver (UAT) and 1090 ES (Extended Squitter) frequency bands. When in range of a ground station, these units will receive FIS-B weather over the UAT link.

The GDL 5XR products provide information to G3X Touch displays via RS-232 and to devices running Garmin Pilot™ via a Connex® data connection (via Bluetooth®). Please see additional information in the *G3X Touch Pilot's Guide for Certified Aircraft* (190-02472-00).



Figure 2-9 – GDL 52R Data Link

### 2.1.10 Antennas

The optional glareshield-mounted GPS antenna (Garmin part number 011-04036-10 or 011-04036-00) feeds a GPS receiver inside the GDU which provides position, velocity, and time data to support various display functions. The GPS data is also passed on to the GSU 25D to provide improved AHRS performance.

A GPS antenna must be connected to the PFD or the Standalone MFD. In a multiple display G3X installation the PFD will pass GPS data to the other displays. A second GPS antenna is not required but may optionally be installed and connected to the MFD for redundancy.

There are other GPS antennas which are compatible with the GDUs, reference Table B-8 for more information.



**NOTE**

*If using GPS antenna 011-04036-00, which has a TNC connector, a TNC/BNC Adapter (p/n 330-01754-00) is required to connect the GPS antenna to the GDU.*

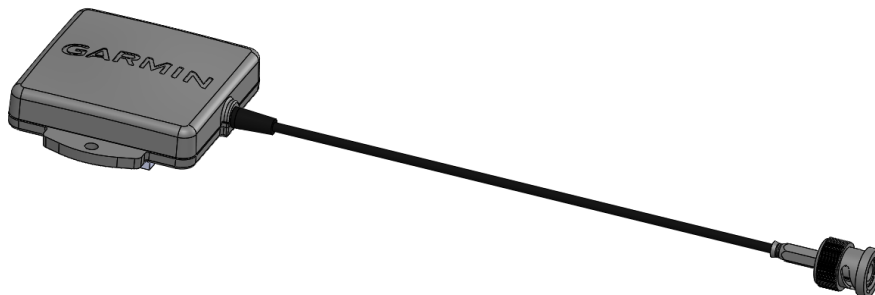

Figure 2-10 – GPS Antenna (011-04036-10 Shown)

### 2.1.11 GAP 26 AOA Probe

The GAP 26 AOA (Angle of Attack) probe is a heated air data probe intended to be used as part of the G3X system.

When installed by this STC, the GAP 26 AOA pressure port is plumbed to the GSU 25D ADAHRS to provide AOA pressure. The GSU 25D will use the pressure from the GAP 26 probe and the pitot/static pressures it already receives from the existing aircraft pitot/static system to determine AOA and subsequently, display it on the G3X PFD.

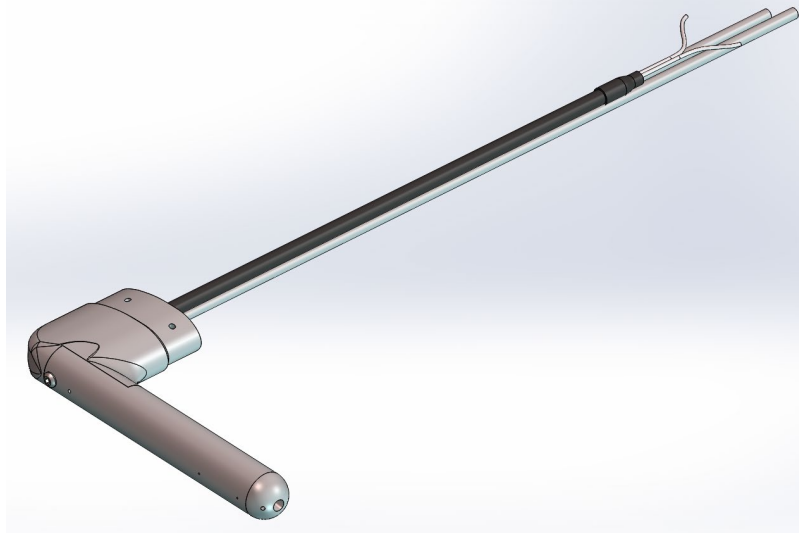

Figure 2-11 – GAP 26 AOA Probe

### 2.1.12 GTR 20 VHF COM Radio

The GTR 20 is a remote VHF COM transceiver that operates in the 118.000 to 136.975 MHz frequency range with a 25 kHz channel spacing. The GTR 20 features a built-in two-place stereo intercom with alert audio, 3D audio, and stereo music inputs.

As installed by this STC, the GTR 20 is a remote mounted COM radio that is entirely controlled by the G3X Touch display with no front-panel interface. Use of the intercom function is optional.



Figure 2-12 – GTR 20 COM Radio

### 2.1.13 GTR 200B VHF COM Radio

The GTR 200B is a VHF COM transceiver that operates in the 118.000 to 136.975 MHz frequency range with a 25 kHz channel spacing. The GTR 200B features a built-in two-place stereo intercom with alert audio, 3D audio, stereo music inputs, and Bluetooth functionality.

As installed by this STC, GTR 200B COM radio can be controlled either by the G3X Touch displays or by its own front-panel controls. Use of the intercom function is optional.



**Figure 2-13 – GTR 200B COM Radio**

**2.1.14 GMA 245R Audio Panel with Marker Beacon**

The GMA 245R is a remote mounted high-fidelity digital audio panel that collects, processes, and distributes audio signals to the pilot and passengers and is fully controlled by G3X Touch displays. It interfaces to dual NAV and COM radios and features a 6-place stereo intercom with 3D audio and Bluetooth capability.

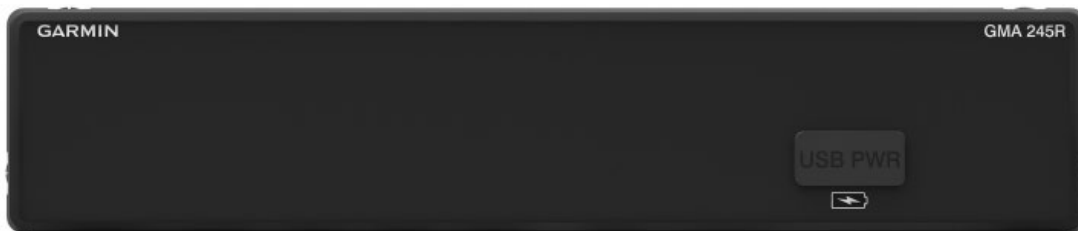
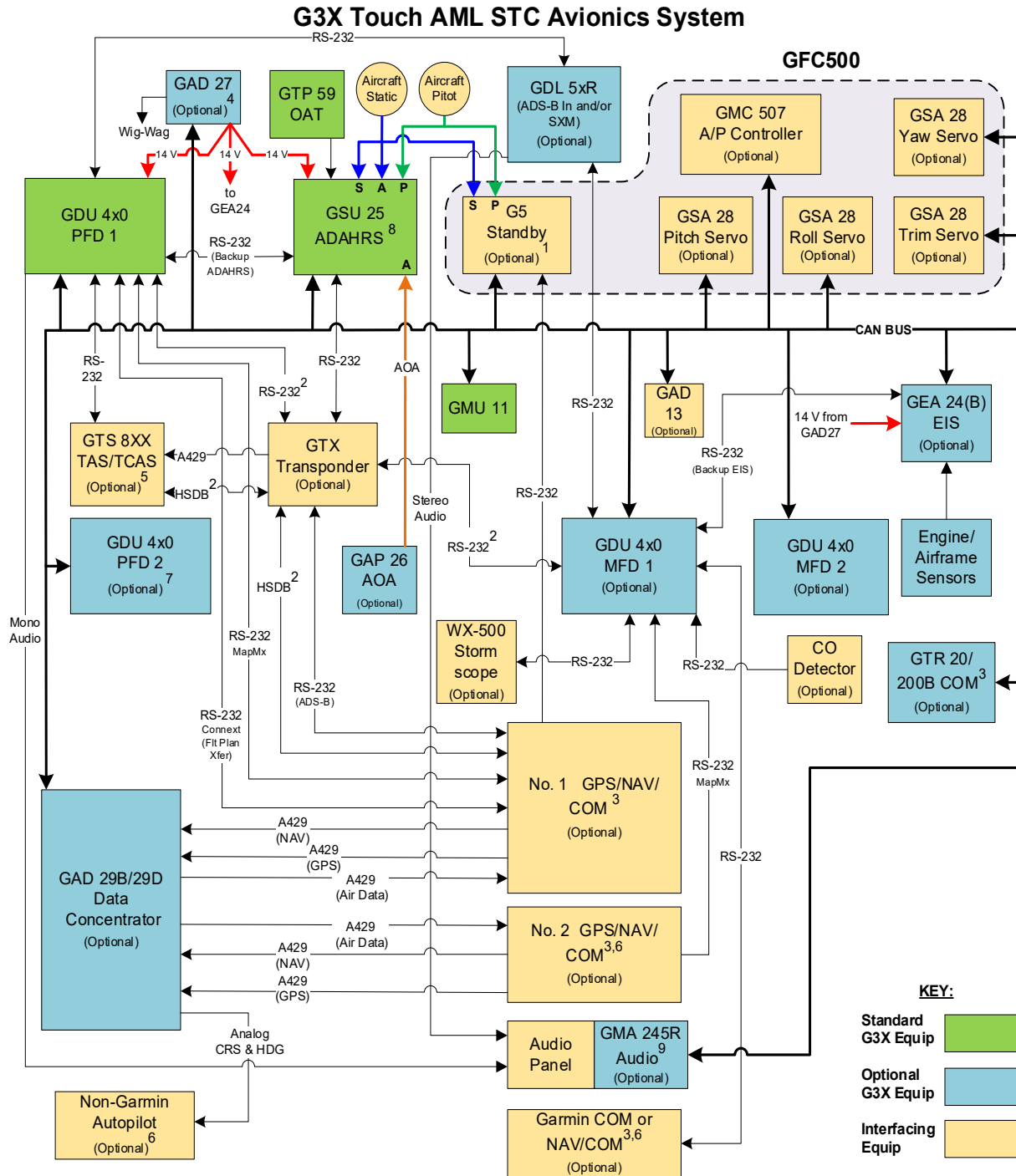

**Figure 2-14 – GMA 245R Audio Panel**

**2.2 G3X Optional Interfaces**

See APPENDIX B for equipment that may be connected to and interfaced with a G3X Touch system.

**2.3 G3X Touch Architecture Example**



**Notes:**

- (1) Standby instrument requirements for G3X PFD installations include the following:
  - a G5 or GI 275 standby instrument is required if Copilot displays are installed in an IFR aircraft
  - a G5 standby instrument is required if a GFC500 autopilot is installed without a Sonalert
  - a GI 275 standby instrument cannot be interfaced directly to a GFC500 autopilot (the GFC500 interfaces only to G3X when using a GI 275 as the standby).
- (2) HSDB & RS232 Connex interfaces are only applicable with GNX 375 or GTX 345() to support FIS-B weather & TIS-B traffic display on GTN & GDUs.
- (3) G3X interfaces to a maximum of two external navigation sources. Supported external navigation sources include IFR GPS, VHF NAV, or combination GPS/NAV receivers. In addition, two COM radios can be selected for display and control on G3X, these can be either standalone COM radios or integrated into one or more of the navigators.
- (4) GAD 27 or TCW IBBS (ref AML STC #SA04400NY) is required for 14v airframes with EIS. GAD 27 may optionally be connected to PFD and GSU 25D in 14v airframes without EIS. GAD 27 may optionally be installed on both 14 and 28 -volt aircraft to enable the landing and/or taxi light “wig wag” feature.
- (5) A GTS 8XX traffic system cannot be interfaced to the GDU if a GNX 375 is installed.
- (6) If a non-Garmin autopilot is installed, only one external navigator (GPS and/or VHF) can be connected to G3X. A second navigator, if installed, must use a dedicated CDI and cannot interface to G3X.
- (7) PFD 2 installation is only allowed on the second panel of a tandem aircraft.
- (8) The AOA port on the GSU 25D is connected to a GAP 26 AOA port, if installed. If a GAP 26 is not installed the AOA port on the GSU is connected to the aircraft’s static line.
- (9) The CAN bus interface to the audio panel is only applicable for a GMA 245R.

**GDU 232 Ports:**

GDUs have six RS-232 ports. Except as noted below, the ports can be connected to any compatible LRU and if multiple GDUs are installed they will share the data between them on the CAN bus. The RS-232 architecture shown above is only an example configuration.

The port on the P4x01 connector is only compatible with the GSU 25D or GEA24(B). The five ports on P4x02 can be configured for any supported interface (including GSU 25D and GEA 24(B)).

When two external navigators are connected, the #1 Nav must be connected to a lower numbered RS-232 port on the PFD, and the #2 Nav connected to either a higher numbered port on the PFD or any 232 port on the MFD.

GTN Connex interface must be connected to PFD1.

Weather data is not shared between GDUs, therefore the traffic/weather receiver (GNX 375, GTX 345() or GDL 5xR) should be connected via RS-232 to each GDU. If both SXM and ADS-B In are desired in a fully optioned single GDU installation (PFD, EIS, and dual Garmin navigators), a GDL 52R should be used for 232 port availability considerations (the 52R sends both SXM and FIS-B/TIS-B on one RS-232 bus). Note however that the GDL 5xR is not compatible with the GTN, so if ADS-B traffic & weather display is desired on both G3X and GTN it must be sourced from a GNX 375 or GTX 345() per Note 2 (alternatively, the GTN could use GDL 88 or GDL 69, but these are incompatible with G3X).

The PFD interfaces to the GI 275 standby instrument via RS-232, so a fully optioned single GDU installation may need to use a G5 standby (with CAN bus interface) to support all desired 232 interfaces. Also, two of the three RS-232 ports on the GI 275 are used for the G3X interface, so the GI 275 standby cannot interface to dual navigators which use RS-232 (e.g. GNS series).

**GTX 335(D)/345(D)R:**

RS-232 port 1 on the GTX335(D)/345(D)R must be used to connect to the GSU 25D.

**G3X Touch AML STC Avionics System – Standalone MFD**

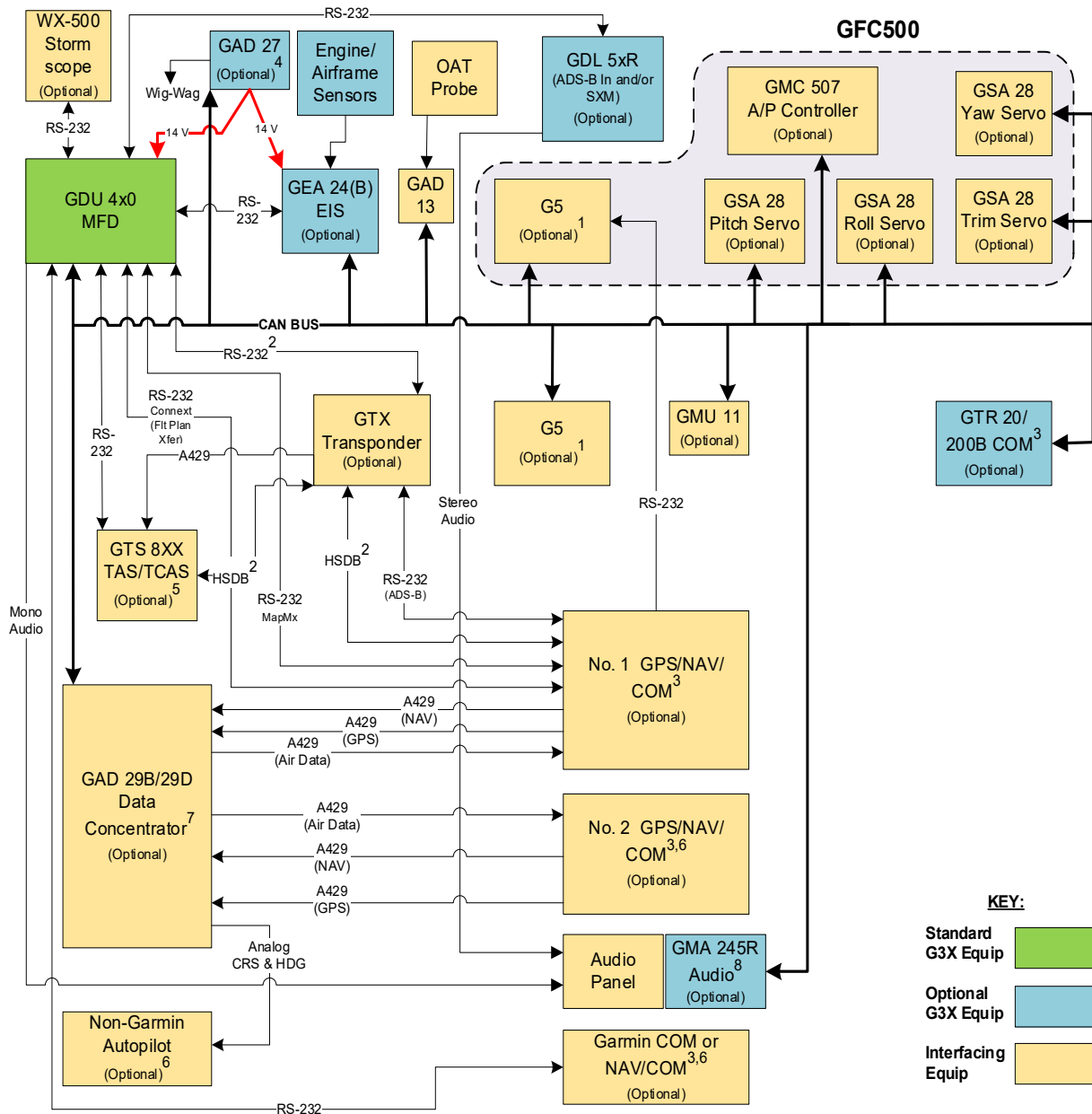

**Figure 2-16 – Example G3X Architecture – Standalone MFD**

**Notes:**

- (1) *If GFC500 is installed with a G3X Standalone MFD, a G5 is required. A second G5 may be installed per the G5 AML STC.*
- (2) *HSDB & RS232 Connex interfaces only applicable with GNX 375 or GTX 345() to support FIS-B weather & TIS-B traffic display on GTN & GDU.*
- (3) *G3X interfaces to a maximum of two external navigation sources. Supported external navigation sources include IFR GPS, VHF NAV, or combination GPS/NAV receivers. In addition, two COM radios can be selected for display and control on G3X, these can be either standalone COM radios or integrated into one or more of the navigators.*
- (4) *GAD 27 or TCW IBBS (ref AML STC #SA04400NY) is required for 14v airframes with EIS. GAD 27 may optionally be installed on both 14 and 28 -volt aircraft to enable the landing and/or taxi light "wig wag" feature.*
- (5) *A GTS 8XX traffic system cannot be interfaced to the GDU if a GNX 375 is installed.*
- (6) *If a non-Garmin autopilot is installed, only one external navigator (GPS and/or VHF) can be connected to G3X. A second navigator, if installed, must use a dedicated CDI and cannot interface to G3X.*
- (7) *The GAD 29B/29D is only required when the standalone MFD is installed with a G5 and GPS navigator. If no G5 is installed, the MFD and GPS navigator communicate only via RS-232.*
- (8) *The CAN bus interface to the audio panel is only applicable for a GMA 245R.*

**GDU 232 Ports:**

*GDUs have six RS-232 ports. Except as noted below, the ports can be connected to any compatible LRU. The 232-architecture shown above is only an example configuration.*

*The port on the P4x01 connector is only compatible with the GEA 24(B). The five ports on P4x02 can be configured for any supported interface.*

*When two external navigators are connected, the #1 Nav must be connected to a lower numbered RS-232 port on the MFD, and the #2 Nav connected to a higher numbered port on the MFD.*

*If both SXM and ADS-B In are desired in a fully optioned standalone MFD installation (MFD, EIS, and dual Garmin navigators), a GDL 52R should be used for 232 port availability considerations (the 52R sends both SXM and FIS-B/TIS-B on one RS-232 bus). Note however that the GDL 5xR is not compatible with the GTN, so if ADS-B traffic & weather display is desired on both G3X and GTN it must be sourced from a GNX 375 or GTX 345() per Note 2 (alternatively, the GTN could use GDL 88 or GDL 69, but these are incompatible with G3X).*



**Table 2-3 – G3X Touch and Supporting Equipment**

EQUIPMENT	SUPPLIER	QTY	STANDARD/ OPTIONAL
GDU 4X0	Garmin	1, 2, 3 or 4	Standard
GSU 25D	Garmin	1	Standard (PFD installations)
GMU 11	Garmin	1	Standard (PFD installations)
GTP 59	Garmin	1	Standard (PFD installations)
GAD 27	Garmin	1	Standard/Optional*
GPS Antenna (011-04036-00 or -10)	Garmin	1	Optional
GAD 29B/29D	Garmin	1	Optional
GDL 5XR	Garmin	1	Optional
GEA 24(B)	Garmin	1	Optional
GTR 20	Garmin	1 or 2	Optional
GTR 200B	Garmin	1 or 2	Optional
GMA 245R	Garmin	1	Optional
GAP 26	Garmin	1	Optional

\*Reference Section 2.1.7 for applicability.

## 2.4 Electrical Power Distribution

Electrical load information for the G3X Touch EFIS system LRUs is provided below in Table 2-4. Appendix A of this document contains details specific to the load changes for the specific aircraft installation.

**Table 2-4 – LRU Current Draw**

LRU	Current Draw – Maximum Amps			
	14V System		28V System	
	Typical	Max	Typical	Max
GAD 27	0.1A	0.1A	N/A	N/A
GAD 29B/29D	0.1A	0.2A	0.1A	0.1A
GDL 50R	0.1A	0.3A	0.1A	0.1A
GDL 51R	0.1A	0.2A	0.1A	0.1A
GDL 52R	0.2A	0.3A	0.1A	0.2A
GDU 460	1.0A	2.0A	0.5A	1.0A
GDU 470	0.6A	1.3A	0.4A	0.7A
GEA 24(B)	0.2A	0.4A	0.1A	0.2A
GSU 25D, GMU11, GTP 59	0.25A	0.35A	0.125A	0.175A
GTR 20	3.0A	7.5A	1.4A	3.75A
GTR 200B	3.0A	7.5A	1.4A	3.75A
GMA 245R	0.32A	1.11A	0.18A	0.87A
GAP 26	8.5A	12.0A	4.25A	6.0A

### 3. G3X CONTROL & OPERATION

The Garmin G3X Touch EFIS is intended for Part 23 aircraft covered by the AML STC # SA01899WI.

The following is an overview of G3X Touch panel-mounted units and display features that are provided by the G3X Touch EFIS.

#### 3.1 GDU 4X0 Softkeys/Features and Control

The GDU 4X0 does not have a power button and will turn ON when power is applied to the aircraft. G3X Touch remote-mounted LRUs also do not have dedicated power buttons but will turn ON when battery power is applied to the aircraft or the dedicated bus power (avionics power) is applied. The G3X GDU has the following controls as shown in Figure 3-1:

- **Dual Concentric Knobs** – Control knobs that can be used to scroll and select through various options on the display. Pressing the knob acts as an enter or selection of the currently highlighted information. The function of each knob on the lower bezel is context sensitive and is identified on the screen just above the associated knob. Reference Section 3.2.2.1 for using the GDU knob in configuration mode.
- **Menu Button** – Used to enter configuration or configuration/diagnostic mode. Reference *Garmin G3X Touch EFIS Part 23 AML STC Installation Manual (190-02472-01)* for specific functions covered in various pages in configuration mode. In normal mode, pressing the MENU button once brings up the “PFD options” and twice will bring up the “Main Menu”.
- **Back Button** – Used to return to a previous section/page.
- **Direct to** – Not used in configuration mode.
- **NRST Button** – Used in conjunction with the MENU button to enter diagnostic mode or with MENU and BACK buttons to reboot the GDU. No other functions in configuration mode.
- **Photocell** – The photocell may be configured to be used by the display to automatically adjust the display backlighting in reference to ambient light conditions.
- **SD Card Slot** – A card slot in the display that accepts standard SD cards. The following list shows the tasks that can be performed via the SD card slot with an SD card installed:
  - Update databases
  - Software updates
  - Datalogging
  - Screenshots
  - Back up Configuration Files

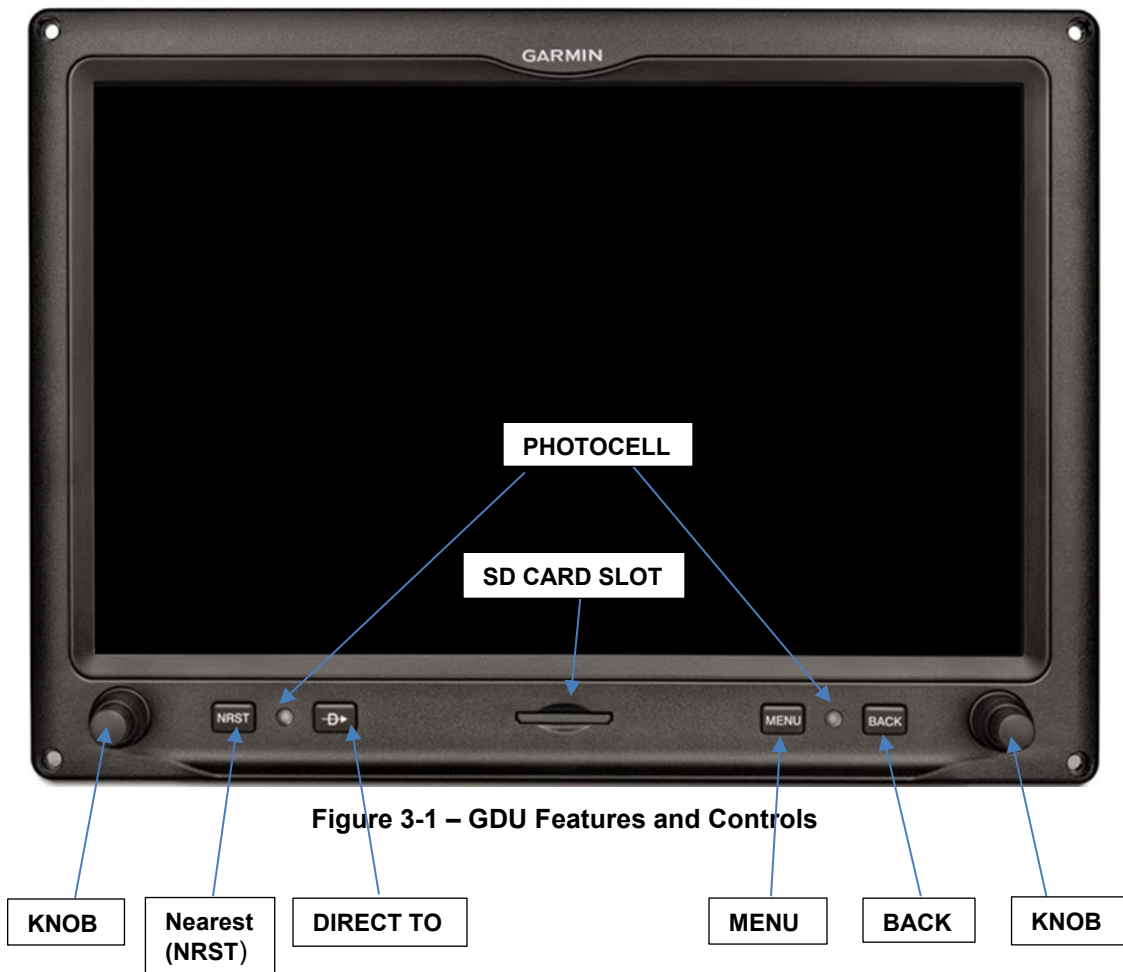

Figure 3-1 – GDU Features and Controls

### 3.1.1 GDU Reboot

- To reboot GDU without turning off aircraft power, simultaneously and momentarily press the BACK, MENU and NRST buttons. If the GDU is in configuration mode, it will reboot to normal mode.
- In configuration mode the GDU may be rebooted back to normal mode by selecting the “Save and Reboot” page.

## 3.2 Display Modes

### 3.2.1 Normal Display Mode

**PFD:** Two PFD display formats are available in normal mode and controlled by the split/full touch field on the upper portion of the display. Refer to Figure 3-2 and Figure 3-3:

- Full display – occupies the entire width of the display
- Split format – 50/50 percent display of PFD instrumentation and a Multi-function pane/window, or a 20/40/40 percent display when the engine bar is present.

The location of the split/full button and the format to be displayed at power up are configured in the Display Configuration page.



Figure 3-2 – Split/Full Format Buttons - GDU 460



Figure 3-3 – Split/Full Format Buttons - GDU 470

The location of the split/full button and the format to be displayed at start up, are configured in the Display Configuration page.



Figure 3-4 – Normal Mode, Full Format – PFD w/ EIS (Example)

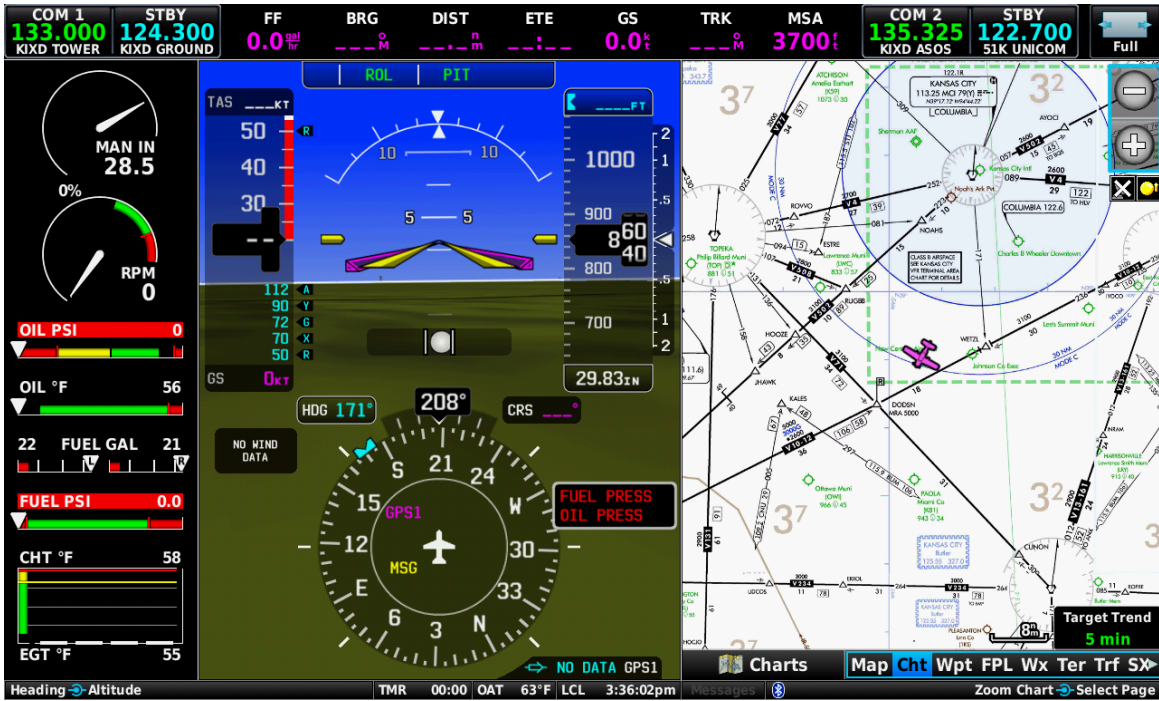

Figure 3-5 – Normal Mode, Split Format – PFD W/ EIS (Example)

**MFD:** provides a multi-function area with various pages and EIS if configured. The display on a 7" GDU 470 when configured as an MFD does not have split format functionality in normal mode but is available in reversionary mode if the PFD fails. In its place the button is used to toggle between MFD and backup PFD functionality.

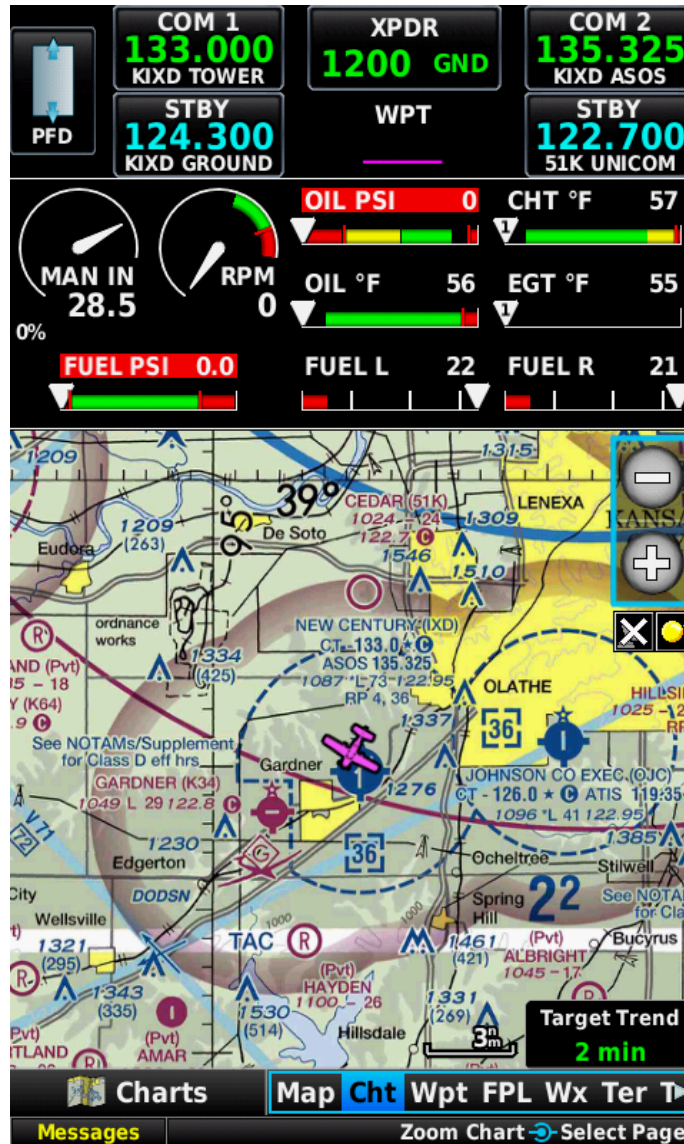

Figure 3-6 – Normal Mode, Full – MFD with EIS (Example)

### 3.2.1.1 Reversionary Mode

In a multiple display installation, a reversionary display mode is supported in the event of GDU failure. When at least two GDUs are installed, one as PFD and the other as an MFD, the system will automatically revert the functioning GDU to a reversionary format in the event of a GDU failure. In the reversionary mode, primary flight information, radio tuning information and EIS (if installed) are displayed on the remaining GDU.

### 3.2.2 Configuration Mode Overview

Throughout this document, references are made to the GDUs being in configuration mode. The configuration mode exists to provide the avionics technician with a means of configuring, checking, and calibrating various G3X Touch system.

To enter configuration mode:

1. Hold down the “MENU” key on the GDU 4X0 while applying power to the aircraft, until the display shows “Configuration Mode” text.

2. Use the “Move Selector” knob or by touching the display panel to make selections and changes.
3. After all configuration changes have been made, use the “Save & Reboot” page to save all changes and return to normal mode.



**NOTE**

*For a complete description and breakdown of each Configuration Mode page, refer to the [G3X Touch EFIS Part 23 AML STC Installation Manual \(190-02472-01\)](#).*

**3.2.2.1 GDU Knob**

The GDU knob has dual concentric knobs; a small inner and a larger outer. GDU 460 has two knobs, one on each side of the lower section, while GDU 470 has one on the right side of the lower section of the GDU. The function of each knob on the lower bezel is context sensitive and is identified on the screen just above the associated knob. If both inner and outer knobs have the same function, the function will be displayed on the screen above the knob; for example, “Move Selector”, “Scroll List”, etc. may be displayed. If the inner and outer knobs have the different functions that would be displayed on the screen. As shown below in Figure 3-7, the outer knob is used to select a tab and the inner knob is used to scroll down a list.



**Figure 3-7 – GDU Knob Function Example**

To cycle through different configuration pages:

To scroll to a particular page: Rotate either the large outer or small inner knob or use the touch panel.

To select a page: Press/push the inner knob or touch the page on the display.

To navigate between different tabs on a page: Rotate the large outer knob or use the touch panel.

To scroll down a list/data field in a tab: Rotate the inner knob or use the touch panel.

To select a data field: Press/push the inner knob or use the touch panel.

**3.2.2.2 Configuration Data Entry**

To change the contents of a highlighted data field, use the either the pop-up keyboard, pop-up keypad, pop-up slider bar or touch panel as applicable.





**Figure 3-8 – Data Entry Options (Examples)**

### 3.2.2.3 System Status Indicators

The “System Information” page in the configuration mode of the GDU 4X0 PFD has a “Devices Online” tab that reports the status of installed LRU’s and their currently installed software part numbers and versions. The icon/checkbox next to each LRU reports a green checkmark, a ‘red x’ or blank checkbox to indicate the status of each LRU as described in Table 3-1.

**Table 3-1 – LRU Status Indicator Symbols**

INDICATION	LRU CONDITION
	The LRU is online and reports the item located next to the indicator box is communicating.
	The LRU is online, and reports the item located next to the indicator box is not communicating, a fault, warning, or error has been detected.
	The LRU is not online.

### 3.2.2.4 Configuration Mode Navigation

Using the PFD knob and data entry options as described in Sections 3.2.2.1 and 3.2.2.2 a user can navigate through different pages and page groups in the Configuration Mode. Reference the *Garmin G3X Touch EFIS Part 23 AML STC Installation Manual (190-02472-01)* on how to make configuration changes.



**NOTE**

*Some configuration pages appear only when certain optional LRUs are installed and configured.*



**Figure 3-9 – Configuration Mode Pages**



### 3.2.3 Configuration/Diagnostic Mode

Troubleshooting and diagnostic information for CAN bus can be viewed in Configuration/Diagnostic mode. For CAN troubleshooting information, reference section 5.2.

To enter configuration/diagnostic mode:

1. Simultaneously hold down the “MENU” and “NRST” key on the GDU 4X0 while applying power to the aircraft, until the “Configuration/diagnostic Mode” text is displayed on the screen.
2. Use the “Move Selector” knob or touch panel to make selections as necessary.
3. After all configuration changes have been made, use the “Save & Reboot” page to save all changes and return to normal mode.

**4. INSTRUCTIONS FOR CONTINUED AIRWORTHINESS**

**4.1 Airworthiness Limitations**

The G3X Touch EFIS is airworthy when installed, configured, and maintained in accordance with this section.

There are no new (or additional) airworthiness limitations associated with this equipment and/or installation.

The Airworthiness Limitations section is FAA-approved and specifies maintenance required under §§ 43.16 and 91.403 of Title 14 of the Code of Federal Regulations, unless an alternative program has been FAA-approved.

FAA APPROVED

*Paul Mast*

Paul Mast  
STC Unit Administrator  
ODA-240087-CE

*9-18-2024*

Date

## 4.2 Servicing Information

G3X Touch EFIS LRUs maintenance is 'on condition' only. No component-level overhaul is required for the G3X Touch EFIS Part 23 AML STC installation. See section 6 for equipment removal and installation.

### 4.2.1 On-condition Servicing

'On Condition' replacement and/or servicing should occur when an item exhibits conditions, symptoms, and/or abnormalities defined in Section 5 of this manual. Replacement and/or servicing should be made only after the technician troubleshoots the system to the extent determined necessary by using the guidance in this manual along with common avionics maintenance practices.



#### NOTE

*It is impossible to provide guidance for every conceivable failure scenario within the scope of this manual. Every effort has been made to provide comprehensive guidance for possible failures. The information in this document should always be combined with sound aviation maintenance practices and a thorough knowledge of the system. Use sound avionics maintenance practices when working around or on G3X equipment.*



#### NOTE

*After replacing or servicing electrical components near the GMU 11 magnetometer, the Magnetometer Interference Test (reference Section 5) and Magnetometer Calibration Procedure (reference Section 7) must be performed.*

The remainder of this document is organized in the following fashion:

- Section 4.3 lists maintenance requirements related to the G3X system.
- Section 5 provides troubleshooting guidance
- Section 6 gives instructions regarding the removal and replacement of physical G3X Touch EFIS equipment and parts.
- Section 7 gives configuration and testing instructions to be accomplished if G3X Touch EFIS equipment or parts are removed or replaced.
- Section 8 specifies system return-to-service procedure.

### 4.2.2 Required Tools

The following tools are needed to perform maintenance tasks on G3X equipment:

- SanDisk brand SD card, 8GB or smaller
- Calibrated Milliohm meter with Kelvin probes or equivalent
- Calibrated digital level
- Calibrated air data test set (pitot/static ramp tester)
- Calibrated VHF NAV/COM/ILS ramp tester or equivalent
- Outdoor line-of-site to GPS satellite signals or GPS indoor repeater
- Headset/microphone
- Ground Power Unit
- Calibrated torque wrench
- Standard sockets & wrenches
- 3/32" Hex tool

## 4.3 Maintenance Intervals

Table 4-1 shows systems and items installed by this STC, which must undergo tests or checks at specific intervals.

**Table 4-1 – Maintenance Intervals**

Item	Description/Procedure	Manual Section No.	Interval
G3X Touch System Visual Inspections	Complete Visual Inspection of all installed G3X system LRUs and wiring harnesses must be performed to ensure continued integrity of the installation.	4.4	12 Calendar Months (During annual inspection)
Electrical Bonding Check	Perform an electrical bonding check of the G3X Touch system LRUs in accordance with Section 4.5.	4.5	Every 2000 flight hours or 10 years, whichever comes first
Pneumatic Drain Check	Perform a pneumatic line drain check if applicable	4.8	12 Calendar Months (During annual inspection)
GDU 4X0 (Qty. 1, 2, 3 or 4)	Removal & Replacement	6.1	On Condition
GSU 25D (ADAHRS)	Removal & Replacement	6.2	On Condition
	AHRS Magnetic Field Model Update	4.6	When available (5-year update cycle)
GMU 11	Removal & Replacement	6.3	On Condition
GTP 59	Removal & Replacement	6.4	On Condition
	Special Inspection Requirements	4.7	On Condition
GAD 27	Removal & Replacement	6.5	On Condition
GEA 24(B)	Removal & Replacement	6.6	On Condition
GAD 29B/29D	Removal & Replacement	6.7	On Condition
GDL 5XR	Removal & Replacement	6.8	On Condition
GTR 20	Removal & Replacement	6.10	On Condition
GTR 200B	Removal & Replacement	6.11	On Condition
GMA 245R	Removal & Replacement	6.12	On Condition
GAP 26	Removal & Replacement	6.13	On Condition
EIS Annunciators	Removal & Replacement	6.14	On Condition
	Lamp Check (If installed)	8.12.4	On Condition
G3X Alerts	Check for and troubleshoot any alerts provided in the alert window per the referenced manual section	5	On Condition
GPS Antenna	Removal & Replacement	6.9	On Condition
<b>G3X Accessories</b>			
GDU Configuration Module (Qty 1)	Removal & Replacement	6.1.1	On Condition
<b>G3X Lightning Protection</b>			
Lightning Strike to Antenna Actual or Suspected	Inspect the GTP 59 and surrounding installation	4.7	On Condition

Item	Description/Procedure	Manual Section No.	Interval
<b>Engine/Airframe Sensors</b>			
Oil Pressure	Removal & Replacement	6.6.1	On Condition
Oil Temperature			
Manifold Pressure			
Carb Air Temp			
Fuel Pressure			
Fuel Flow			
Garmin Restrictor fitting	The 0.016-inch orifice in the Restrictor fitting may become plugged and require cleaning.	6.6.1.1.1	On Condition

#### 4.4 Visual Inspection

Operation of the G3X Touch system is not permitted unless a visual inspection, as described in this section, has been completed within the preceding 12 calendar months. Check for corrosion, damage, or other defects for each of the G3X Touch LRUs. Replace any damaged parts as required. Inspection may require the temporary removal of a unit or units to gain access to connectors. Follow guidance in Section 6 for equipment removal and replacement.

Conduct the following visual inspection of the G3X Touch EFIS system LRUs and associated wiring harnesses to ensure installation integrity:

1. Inspect all units for security of attachment, including visual inspection of brackets and other supporting structure attaching all units to the airframe.
2. Inspect all switches, annunciators, knobs, and buttons for legibility.
3. Inspect displays for legibility and acceptable brightness. Reference Section 5.3.1.
4. Visually inspect each unit's wiring (including electrical bonding straps), overbraid, and connectors for chafing, deterioration, damage, or wear.
5. Visually check for any signs of corrosion.

##### 4.4.1 Aluminum Foil Tape (Non-metallic Aircraft Only)

Any aluminum foil tape if used in the G3X Touch installation for grounding of a GSU 25D, GEA 24(B), GAD 29B/29D or GAD 27, (refer to Appendix A of this document) must be inspected every 12 calendar months.

The inspection must verify that the foil tape is not torn, damaged, or showing signs of corrosion. If any of these conditions are found, the tape must be replaced in accordance with Section 4 of *G3X Touch EFIS Part 23 AML STC Installation Manual*.

#### 4.5 Electrical Bonding Test

G3X Touch EFIS LRU electrical bonding must be checked every 2,000 flight hours or 10 years, whichever occurs first.

##### 4.5.1 Requirements

- Disconnect any cables and connectors normally attached to the LRU.
- Resistance must be measured from a bare metal portion of the LRU to an airframe grounding location.

The airframe grounding location should be as close to the LRU as possible, unless otherwise noted in Table 4-2.

##### 4.5.2 Test Equipment

Calibrated 4 wire Milliohm meter and Kelvin probes are required for this test.

##### 4.5.3 Electrical Bonding Test Procedures.

- Using a calibrated milliohm meter and Kelvin probes, measure the resistance of each G3X Touch LRU between the locations noted in
- Table 4-2, and record the result of each installed LRU. Some equipment on the list are optional and may not be installed.
- Ensure the resistance does not exceed 10 milliohms for equipment in Table 4-2 except GAP 26 which should not exceed 20 milliohms.
- If the measured resistance is greater than allowed, bonding must be improved to meet applicable requirements for a new installation in accordance with Section 4 of *G3X Touch EFIS Part 23 AML STC Installation Manual* (190-02472-01).

**Table 4-2 – Electrical Bonding Procedure**

Unit	Measurement Location (3)	Result (milliohm)
GDU 4X0 (PFD)	J4X02 backshell to ground stud (2)	mΩ
GDU 4X0 (MFD) (if installed)	J4X02 backshell to ground stud (2)	mΩ
GSU 25D (1)	Chassis mounting screw to adjacent aircraft ground	mΩ
	P251 backshell to ground stud (2)	mΩ
GMU 11	P111 backshell to ground stud (2)	mΩ
GAD 29B/29D	Chassis mounting screw to adjacent aircraft ground	mΩ
GAD 27	Chassis mounting screw to adjacent aircraft ground	mΩ
GEA 24(B)	Chassis mounting screw to adjacent aircraft ground	mΩ
GDL 5XR	P5X1 backshell to ground stud (2)	mΩ
GTR 20	Chassis mounting screw to adjacent aircraft ground	mΩ
GTR 200B Rack	Rack/chassis mounting screw to adjacent aircraft ground	mΩ
GMA 245R	Chassis mounting screw to adjacent aircraft ground	mΩ
GAP 26	Mount tube bracket screw to adjacent aircraft ground	mΩ

**Notes:**

- (1) For remote mounted – it is bonded via the chassis mounting to aircraft ground.  
For GDU-mounted – it is bonded via bonding strap to a ground stud
- (2) This is the ground stud that the LRU bonding strap is connected to.
- (3) For remote LRUs bonded to the back of the instrument panel via an installed aluminum foil ground plane, the bonding measurement must be taken between the remote LRU and the instrument panel.

**4.6 GSU 25D Earth Magnetic Field Updates**

The GSU 25D utilizes an Earth magnetic field model which is updated once every five years. The IGRF (International Geomagnetic Reference Field) update is expected to be available from Garmin in July 2020 and every five years thereafter, as long as the GSU 25D remains a Garmin-supported product.

The IGRF model is automatically updated with the navigation database for G3X software versions 9.15 and later. The G3X system alerts the operator that the magnetic field database is out of date by issuing the message "AHRS IGRF data out of date".

**4.7 Special Inspection Requirements**

After a suspected lightning strike, the following actions must be performed for the specific LRU.

**GTP 59 Temperature Probe**

Inspect the GTP 59 temperature probe for signs of lightning damage. Check the self-sealing washer (P/N 212-00026-00) used on the probe tip outside of the aircraft for any evidence of melting or lack of seal. Replace the washer if damaged. If there is evidence of lightning strike to the GTP 59 temperature probe or any lightning damage, replace the probe.

Tube-and-fabric aircraft must replace the GTP 59 bond strap (if installed) in accordance with Section 4 of the *G3X Touch EFIS Part 23 AML STC Installation Manual* (190-02472-01).

**G3X Equipment**

All G3X equipment should be checked per Section 7. If equipment is not functioning correctly, troubleshoot using information in Section 5. Contact Garmin Product Support before replacing G3X LRUs to verify all troubleshooting options were exhausted.

#### **4.8 Pneumatic Line Drain Check (If installed)**

Check of the pneumatic line drain to verify positive drainage must be performed every twelve months or during annual inspection, whichever comes first.

- Locate the pitot/static/AOA line drain if installed. Refer to the location information recorded in APPENDIX A of this document and maintained with the aircraft records.
- Open the drain plug to empty any moisture in the system.
- Reinstall the drain plug.
- Perform applicable checkout procedures in Section 8 (8.13.1 and 8.19.2).



## 5. TROUBLESHOOTING

This section provides instructions and guidance for G3X Touch EFIS troubleshooting.

Troubleshoot the G3X Touch EFIS by first identifying, then isolating the specific failure to the responsible LRU. There are several indications the G3X Touch EFIS presents to the pilot or technician, showing overall system condition. A course of action should be determined based on the information presented on the display. This section shows possible scenarios likely to be encountered during normal operation and provides troubleshooting guidance to the technician to resolve problems. Reference the interconnect diagrams on the *G3X Touch EFIS Part 23 AML STC Installation Manual* (190-02472-01) and retained with aircraft permanent records while troubleshooting the G3X system.

In this manual, the term 'Red-X' refers to a red "X" that appears on different areas of the display to indicate the failure of that specific function.



### IMPORTANT

*Sections 6, 7 and 8 provide detailed instructions on equipment removal, replacement, configuration, and return-to-service testing. Anytime a G3X Touch component or LRU is removed, swapped, or replaced, the technician must follow the procedures given in Sections 6, 7, and 8 to ensure proper operation of the system.*

Refer to the *G3X Touch Pilot's Guide for Certified Aircraft* (190-02472-00) for a complete listing of System Status Messages.

For additional assistance, contact a G3X Touch Dealer, or Garmin Aviation Product Support at US Toll Free Number 1-888-606-5482, or US 1-913-397-8200.



### NOTE

*Any warning message indicated on the "Messages" field or anywhere on the display while on-ground should be investigated and resolved before flight.*



### NOTE

*The information in this section is for troubleshooting use only and does not supersede any approved Maintenance or Installation Manual instructions.*

### 5.1 General Troubleshooting

1. Review the airframe logbook to verify if any G3X Touch EFIS or other avionics/electrical maintenance had been performed recently that may have contributed to the failure.
2. Check for loose wire terminals on the circuit breaker connections on the power wire(s) causing intermittent power connections. Also, check for intermittent circuit breakers.
3. Connect an auxiliary ground power unit and apply power to the aircraft.
4. Turn ON the G3X Touch EFIS and record the system software level on the GDU start up page.
5. After the system is initialized, note any Red-X's on the displays, ALERT messages and Red-X's on the GDU.

If the failure cannot be verified, proceed to the following physical inspection.

1. Turn off the G3X Touch EFIS and remove the interior panels (as required) to gain access to the ADAHRS. Inspect the physical installation of the affected LRU.
2. Check that the connectors are fully seated, and that the jack screw connectors are fully tightened on both sides of the affected LRU's connector.
3. Check for a loose wire harness that could move around during flight. This condition may cause the wire to pull on or vibrate the connector, creating intermittent connections.
4. Ensure the affected LRU is mounted securely. Check the tightness of the mounting hardware.

5. Look in the vicinity of the affected LRU for any heavy objects that may not be securely fastened to the structure, inducing vibration in the ADAHRS.
6. Look for evidence of water or fluid contamination in the area around the affected LRU.
7. Disconnect the affected LRU's connector(s) and check for bent pins.
8. Inspect the wire harness clamp on the rear of the connector to verify that it is not too tight and smashing/shorting the wires. If the wire clamp is installed upside down, it has sharp edges that can cut into the wires. Verify the presence of protective wire wrap between the wires and the clamp.

If the condition is not resolved by following the preceding instructions, use data in this section before contacting Garmin Product Support for additional assistance. A Garmin Field Service Engineer may ask the technician to download the fault logs via an SD card and email the logs back to Garmin to help determine the root cause.

## 5.2 CAN Bus Network Troubleshooting

If communication problems between LRUs are suspected, the CAN bus wiring and arrangement of devices on the network should be examined.

1. Review the status LED of devices on the CAN bus. The GAD 29B/29D, GEA 24(B), GSU 25D, GAD 27, GTR 20 and GSA 28 (if GFC 500 is installed) have an LED on their outer cases that indicates the LRU's current status. The status indications are shown in Table 5-1:

**Table 5-1 – Status LED Indications**

LED Indication	Description
No light	No power
Steady Green	ON, but not communicating via the CAN Bus
Flashing Green	ON, and communicating via CAN Bus
Red	Hardware Fault
Alternating Green/Red	CAN Bus network error, two similar devices are configured with the same unit ID

2. Use the guidance in Table 5-2 to troubleshoot LED indications.

**Table 5-2 – LED Indications Recommended Action**

LED Indication	Description	Recommended Action
No light	No power	Verify the circuit breaker, power and ground wiring between the circuit breaker and the affected unit. Replace the unit if power is available to the unit. <i>Contact Garmin Product Support before replacing unit to determine all troubleshooting options have been completed.</i>
Steady Green	ON, but not communicating via the CAN Bus	Inspect and verify the CAN Bus wiring between the G3X Touch and the unit
Flashing Green	ON, and communicating via CAN Bus	None.
Red	Hardware Fault	Contact Garmin Product Support (unit may need to be replaced)
Alternating Green/Red	CAN Bus network error, two similar devices are configured with the same unit ID	verify the Unit ID strapping on the G3X units. Reference the <i>G3X Touch EFIS Part 23 AML STC Installation Manual</i> (190-02472-01) wiring diagrams for strapping details

3. Ensure proper installation of the CAN bus and that the following guidance was adhered to during installation:
  - The CAN bus backbone must be a single linear path with exactly two distinct ends. CAN bus connections must be “daisy-chained” from device to device. Avoid “star” and “Y” topologies, and do not use a hub device. Reference Figure 5-1.

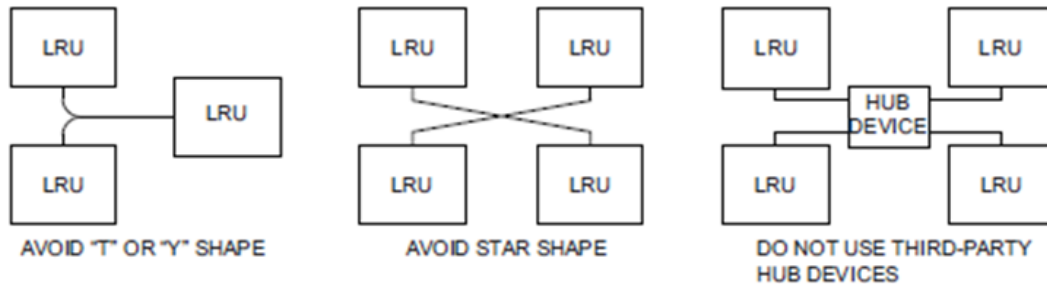

**Figure 5-1 – Incorrect CAN Bus Topographies**

- The overall length of the bus must not exceed 100 feet.
    - Ensure any existing part number M27500 wire if retained for the CAN bus wiring does not exceed 60 feet in overall length. Approved CAN wiring P/N GF120-24CANB-1/GF120T-24CANB (GigaFlight Connectivity) and P/N CAN24TST120(CIT) (Carlisle IT) may have lengths in excess of sixty feet.
  - Do not connect more than one device to the CAN bus backbone at the same point. Instead, daisy-chain the CAN bus backbone from one device to the next.
  - Observe proper wiring, shielding, and grounding requirements as described above.
  - Terminate the CAN bus at the two extreme ends of the bus, as described above.
  - When adding a new device to the CAN bus, evaluate proposed modifications to the CAN bus wiring connections to ensure compliance with all above requirements and the *G3X Touch EFIS Part 23 AML STC Installation Manual (190-02472-01)*.
4. Ensure the CAN bus is terminated in only two locations, and only at the extreme ends of the CAN bus.

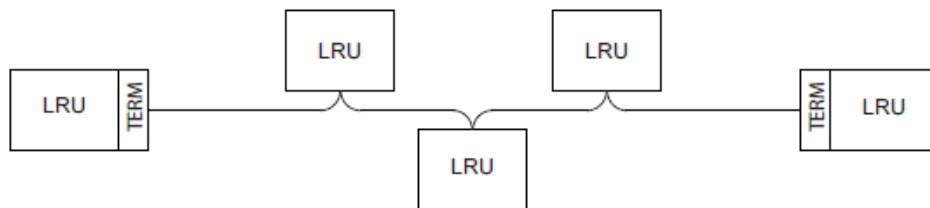

**Figure 5-2 – Correct CAN Bus Wiring Example and Node Connections**

5. Ensure the 15 ohm resistors on the CAN bus inputs to the G5 are correctly installed. If the G5 is also at one end of the CAN bus, verify that the 120 ohm terminator resistor is correctly installed in relation to the 15 ohm resistors. Reference the CAN Bus Termination section of the *Garmin G5 Electronic Flight Instrument Part 23 AML STC Installation Manual (190-01112-10)* for more information.
6. With power removed, remove a connector from one of the devices that is not located at either of the extreme ends of the CAN bus.



**NOTE**

*Do not perform this test on the G5 (if installed as a standby flight display).*

- a. Using an ohm meter, verify that the resistance between the CAN HI and CAN LO pins on the connector is 60 ohms. This will verify that the CAN backbone is properly terminated at each end (two 120 ohm terminating resistors in parallel).
  - b. A resistance of 120 ohms indicates that one of the two required CAN terminations is missing.
  - c. A resistance of 40 ohms or less indicates that too many terminations are installed.
  - d. Verify that the CAN HI and CAN LO signals are not shorted to ground (this can happen when shielded wire is installed incorrectly).
  - e. Measure the resistance between CAN HI and shield ground, and CAN LO and shield ground. Verify resistance is several hundred kilohms (KΩ) or greater.
7. Verify that the CAN HI and CAN LO signals are not swapped or open-circuited at any LRU connector.
  8. Power the G3X system and with GDUs in configuration/diagnostic mode, reference section 3.2.3.
    - Using Touch Panel or a Move Selector Knob to select and view the System Information Page.
    - Scroll the Device List box and the select each device and verify the value displayed for Network Error Rate is a steady 0% (Figure 5-3). Also verify the other network counts values listed on Table 5-3.

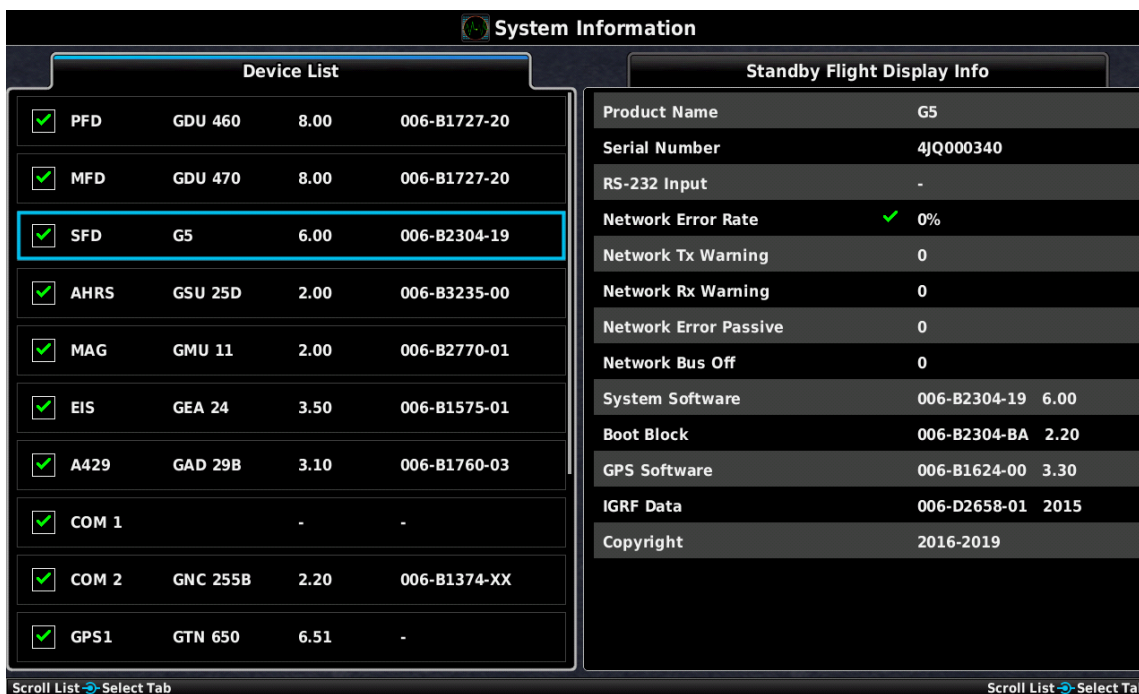

Figure 5-3 – Network Error Rate (Configuration/Diagnostic Mode)



**NOTE**

CAN issue might not be with the unit reporting CAN errors but could be anywhere in the CAN bus system. Table 5-3 is used as a guidance for determining if CAN bus is causing errors while troubleshooting unit or system errors.

Table 5-3 – CAN Network Error Values (Configuration/Diagnostic Mode)

CAN INFO DESCRIPTION	VALUE	POSSIBLE CAUSE	ACTION
Network Error Rate	> 0%	CAN bus wiring problem	Troubleshoot wiring and connection issues that might create CAN errors

CAN INFO DESCRIPTION	VALUE	POSSIBLE CAUSE	ACTION
Network Tx Warning	Increasing $\geq 1$ per minute	CAN bus wiring problem	Troubleshoot wiring and connection issues that might create CAN errors
Network Rx Warning	Increasing $\geq 1$ per minute	CAN bus wiring problem	Troubleshoot wiring and connection issues that might create CAN errors
Network Error Passive	$\geq 2$	CAN bus wiring problem	Troubleshoot wiring and connection issues that might create CAN errors
Network Pass Off	$\geq 2$	CAN bus wiring problem	Troubleshoot wiring and connection issues that might create CAN errors

- Power up only the PFD display and one CAN device at a time and verify the connection quality for each device. Sometimes a device will only communicate with PFD when it is the only powered device on the CAN bus, if one or more of the above issues is present. Evaluating each CAN device in turn can help narrow down a problem.

### 5.3 GDU 4X0

#### 5.3.1 Display Legibility

Degradation of the GDU 4X0 LCD or backlight may reduce legibility. Backlight brightness may also be adversely affected by issues with an external lighting bus or the photocells in the GDU bezel. If display elements are not easily legible under all lighting conditions encountered in the cockpit including direct sunlight, verify that the backlight can be adjusted to an acceptable brightness level via the manual dimming control in the PFD menu. If manual dimming adjustment results in acceptable legibility, troubleshoot the external lighting bus input for incorrect input voltage levels. Verify photocell lenses are clean and unobstructed. Backlight dimming configuration for lighting bus or photocell should be verified in Configuration Mode and may be adjusted as needed. Reference the *G3X Touch EFIS Part 23 AML STC Installation Manual* (190-02472-01) for further detail.

If the above steps do not result in acceptable display legibility the GDU may need to be replaced. Contact Garmin Product Support for more information.

#### 5.3.2 SD Card Slot

A stuck or sticking SD card issue can sometimes be caused by the card thickness variability (especially if there is more than one label on the card). This is usually caused by the card sticking in the overlay opening, not by the card sticking to the socket inside the unit. Try another card (without a label if possible) to confirm the problem before returning. If the second card sticks, the SD socket board inside the unit may be misaligned with the overlay and the GDU will require repair. If the thickness of the card was the cause, see if more than one label was on the card. If the labels weren't the cause, determine what brand of SD card was being used (Garmin recommends using SanDisk® brand cards with a maximum capacity of 8 GB).

Replace any corrupted SD card that might be causing an issue.

#### 5.3.3 Data Logging

Data logging on the G3X Touch GDU may be used to help troubleshoot issues. Operational data is gathered from the G3X Touch during flight or on ground and is stored in \*.csv log files on the SD card (if installed and enabled).

#### 5.3.4 Unit Communication Error Messages (Dual GDU Installations)

Error messages occur if there is a mismatch in GDU software versions. If this occurs, the GDU's will not communicate with each other, and a software mismatch message will be reported on the "Messages" page.

Use the touch panel to select the yellow “Messages” field  or select Main Menu > Tools > Messages, to view the error messages. Ensure both displays are running the same software version to clear the issue. Unit communication error related messages and recommended actions are shown on Table 5-4.

**Table 5-4 – Unit Communication Error Messages (Dual GDU Installations)**

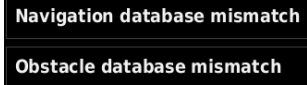
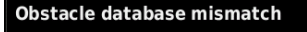
Failure Message	Possible Cause	Recommended Action
GDU software version mismatch	The two GDU displays are using incompatible software versions	Update software to latest on the GDU with incorrect software version
“[UNIT]” network address changed”	State of a GDU's mode pins was detected to have changed.	Check for loose connections and reference the <i>G3X Touch EFIS Part 23 AML STC Installation Manual</i> (190-02472-01) for information on GDU mode pin connections
“GDU COMM ERROR – CHECK GDU WIRING” 	Indicates that more than one GDU is configured to be the same unit type (e.g. two displays are configured as PFD)	Verify and correct GDU mode pin connections per the <i>G3X Touch EFIS Part 23 AML STC Installation Manual</i> (190-02472-01)
[Navigation/Terrain/Obstacle] Database Missing	Indicates that a required database is missing on the specified GDU display.	Update databases as required.
[Navigation/Terrain/Obstacle] Database Mismatch  	Indicates that the GDU displays have different versions of the specified database.	Update the databases in all GDU displays to the same cycle number.

### 5.3.5 GDU Reboot During Engine Start in a 14-volt Aircraft

If the GDU display inadvertently reboots during engine start, troubleshoot aircraft electrical system for anything that might result in low bus voltage during engine start, reference Table 5-5 for recommended actions.



**NOTE**

*Flickering and dimming during engine start are not considered rebooting. The display has to turn off and initialize again (generally requiring 20-30 seconds) to be considered a reboot.*

**Table 5-5 – GDU Reboot During Engine Start**

Symptom	Possible Cause	Recommended Action
GDU display reboots during engine start (14-volt aircraft only)	Low bus voltage	Troubleshoot aircraft electrical system for: <ul style="list-style-type: none"> <li>✓ insufficient battery capacity</li> <li>✓ poor starter performance</li> <li>✓ insufficient wire gauge in starter circuit</li> <li>✓ high resistance through wire connections, circuit breakers, or solenoids</li> <li>✓ other issues in the starter circuit and primary power distribution system</li> </ul>
		Verify that the Electrical Load Analysis and Battery Capacity Analysis have been performed with satisfactory results per the <i>G3X Touch EFIS Part 23 AML STC Installation Manual</i> (190-02472-01) Sections 3.6.1 and 3.6.2.
		Install a GAD 27 or TCW IBBS  If troubleshooting does not reveal any anomalies in the aircraft's battery or electrical system, a GAD 27 or TCW IBBS may be optionally installed per the <i>G3X Touch EFIS Part 23 AML STC Installation Manual</i> (190-02472-01) to address the issue

## 5.4 GSU 25D ADAHRS and GMU 11 Magnetometer Troubleshooting

### 5.4.1 Air Data Troubleshooting

Under normal operating conditions, the ADAHRS provides the following air data information:

- Total Air Temperature is measured
- Outside Air Temperature (OAT) – A valid OAT will display a number
- Indicated Airspeed (IAS)
- True Airspeed (TAS) – A valid OAT value is required to calculate TAS
- Barometric Altitude
- Density Altitude
- Pressure Altitude
- Static Pressure
- Differential Pressure





#### NOTE

*TAS information can only be displayed at speeds greater than 20 Knots (TAS is invalid when the aircraft is sitting still, or if no OAT probe is connected).*

Reference Table 5-6 for troubleshooting guidance.

**Table 5-6 – ADAHRS and Magnetometer Troubleshooting**

Symptom or Failure Message	Possible Cause	Recommended Action
Heading failure (Red X'd intermittently or steady) 	Improper installation of the GMU 11 and/or GSU 25D	Verify GMU 11 and GSU 25D mounting locations are in accordance with the <i>G3X Touch EFIS Part 23 AML STC Installation Manual</i> (190-02472-01)
	Excessive magnetic interference ( <i>determine if any new equipment has been installed on the aircraft near the magnetometer</i> )	Perform the magnetic interference test in Section 5.4.4
	Magnetic anomaly ( <i>If detected, and the aircraft is determined to be stationary, the value of the heading output is frozen. When either the aircraft is determined to be no longer stationary or the magnetic anomaly ceases, heading will be unfrozen and determined as useable. In this context, the aircraft is considered to be stationary when its yaw rate is less than 1.0 degrees/second and all other angular rate and acceleration values are sufficiently small. (moving or shaking the wings or tail for example can cause a Red-X to be displayed).</i> )	If this error shows up repeatedly, conduct the magnetic interference check in Section 5.4.4
Magnetic heading not present	Communication lost between GSU 25D and GMU 11	Inspect GMU 11 wiring Ensure the GMU 11 installation is in accordance with the <i>G3X Touch EFIS Part 23 AML STC Installation Manual</i> (190-02472-01)
AHRS not receiving magnetometer data	Communication lost between GSU 25D and GMU 11	Inspect GMU 11 wiring Ensure the GMU 11 installation is in accordance with the <i>G3X Touch EFIS Part 23 AML STC Installation Manual</i> (190-02472-01)
Attitude failure (Red X'd intermittently or steady) 	ADAHRS and/or Magnetometer not calibrated	Perform pitch/roll compensation offset and magnetometer calibration as per Section 7
	ADAHRS unable to compute valid attitude data due to insufficient or invalid sensor information	Replace GSU 25D  <i>Contact Garmin Product Support before replacing unit to determine all troubleshooting options have been completed.</i>
Both OAT and TAS failure 	OAT is unavailable	<ul style="list-style-type: none"> <li>✓ Inspect GTP 59 OAT probe wiring and connection for faults.</li> <li>✓ Replace the GTP 59 OAT probe.</li> <li>✓ Inspect GSU 25D wiring and connections for faults</li> </ul>

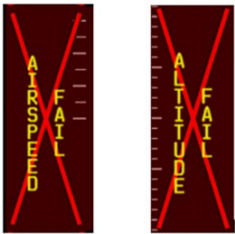
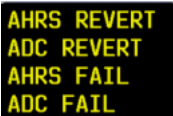

Symptom or Failure Message	Possible Cause	Recommended Action
		<ul style="list-style-type: none"> <li>✓ If the problem persists, replace the GSU 25D with a known good unit</li> </ul>
TAS has a dashed-out value 	True airspeed being measured is too low to be of value (e.g. when the aircraft is on the ground). If the TAS indication remains dashed out at speeds greater than 20 knots and/or the OAT indication is Red -X'd continue with recommended action above for OAT and TAS failure.	None
Airspeed and/or Altitude failure 	Pressure sensor is out of range (possibly due to improper plumbing such as pitot and static lines reversed)	<ul style="list-style-type: none"> <li>✓ Inspect ADAHRS pitot/static plumbing integrity.</li> <li>✓ Inspect pitot/static ports and associated equipment.</li> <li>✓ If a periodic altimeter test, performed with properly calibrated static system test set, indicates that the ADAHRS static pressure sensor needs to be re-calibrated, follow the procedures described in Section 7.2.1.3.</li> <li>✓ If the problem persists, replace the GSU 25D with a known good unit</li> </ul>
	No power to GSU 25D (if Heading, Attitude and OAT are also red-x'd)	<ul style="list-style-type: none"> <li>✓ Ensure GSU 25D circuit breaker is not open.</li> <li>✓ Inspect wiring and electrical connections</li> <li>✓ If problem persists, replace the GSU 25D with a known good unit.</li> </ul>
AOA visual or aural indications are incorrect	Pressure sensor is out of range, leakage in pneumatic lines	<ul style="list-style-type: none"> <li>✓ Inspect ADAHRS pitot/static/AOA plumbing integrity.</li> <li>✓ Inspect pitot/static/AOA ports and associated equipment.</li> <li>✓ Perform the pitot/static/AOA leak checks in sections 7.2.1 and 8.19.2.</li> <li>✓ If the problem persists, replace the GSU 25D with a known good unit.</li> </ul>
	GSU 25D has failed (installed with a G5 or GI 275 standby).	<ul style="list-style-type: none"> <li>✓ Ensure GSU 25D circuit breaker is not open.</li> <li>✓ Inspect wiring and electrical connections</li> <li>✓ If problem persists, replace the GSU 25D with a known good unit.</li> </ul>

### 5.4.2 Heading Red-X



Figure 5-4 – Heading Failure Indication

If a Red-X (steady or intermittent) or a yellow (degraded) is displayed on the heading (Figure 5-4), use guidance in Table 5-6 and check the following while the aircraft is on the ground:

1. When taxiing without reliable GPS information, heading performance is susceptible to the presence of magnetic anomalies (metal buildings, underground steel culverts, steel grates in the ramp, rebar). Localized sources of interference on the ground may consistently cause a Red-X to be displayed on the heading in the same spot while taxiing, this is not caused by a failure of the GMU or its calibration.
2. When the aircraft is taxiing on the ground with a yaw rate of less than 2.5 degrees/second (i.e., taxiing essentially in a straight line) GPS track information is used to update heading information. This logic is applied regardless of magnetic anomaly detection.

### 5.4.3 Attitude/Heading Failure Troubleshooting

The ADAHRS may not be able to provide valid heading/pitch/roll data for the following reasons:

1. If an "ADAHRS not Calibrated" message is displayed, the external installation configuration parameters are not calibrated and the ADAHRS pitch/roll compensation offset (Section 7.2.1.1) and/or Magnetometer calibration (Section 7.2.1) need to be performed. If either of these is not calibrated, the ADAHRS heading, pitch, and roll may all be flagged as invalid. Calibrate the unit to the installation.
2. The ADAHRS is unable to compute valid attitude information due to insufficient or invalid sensor information being provided.



**Figure 5-5 – Attitude Failure Indication**

If the attitude is failed and shows a Red-X condition, follow the troubleshooting steps in the Section 5.1. If this does not resolve the issue, use guidance in Table 5-6, before gathering answers to the following questions. This information may be helpful to the customer, the avionics dealer, or to Garmin Aviation Product Support in troubleshooting the failure:

1. What specifically was the nature of the failure? Was it a Red-X of only heading, only pitch/roll, or both?
2. If there was a Red-X of pitch or roll information, did the PFD display the "ADAHRS Align: Keep Wings Level" message (which is indicative of an ADAHRS reset), or the "Attitude Fail" message (which is indicative of either ADAHRS invalidating its output, or a communication path failure)?
3. What exactly was the aircraft doing in the two minutes that preceded the failure (taxiing on the ground, flying straight-and-level flight, turning, climbing, etc.)? If the problem occurred on the ground, was it within 100 feet of a hangar using GPS repeaters?
4. How long did the failure last? Was it brief or sustained? Was it repetitive in nature? If it was repetitive, about how many times did it happen? Did it happen on more than one day?
5. Was the problem correlated with a specific maneuver or a specific geographic area?
6. Can the problem be repeated reliably?
7. Were any of the following message advisory alerts observed on the display or messages field within an hour of the occurrence of the problem?

- ADAHRS not receiving airspeed
  - ADAHRS not receiving any GPS information
  - ADAHRS magnetic-field model out of date
  - ADAHRS extended operation in no-GPS mode
8. Did the onset of the problem occur shortly after a software upload to the G3X Touch system, or shortly after a repeat of the magnetometer calibration procedure? Were there any GPS Alert messages or loss of position lock?

### 5.4.4 Magnetometer Interference Test



**NOTE**

The Magnetic Interference Test is only required for initial installation verification. This test should also be repeated to verify all subsequent electrical changes associated with devices within 10 feet of the GMU magnetometer. Such changes include, but are not limited to, wiring, shielding, or grounding changes to any light, strobe, beacon, or other electrical device located in the vicinity of the GMU magnetometer unit. Likewise, this test should also be repeated to verify all subsequent changes to materials within 10 feet of the GMU magnetometer. Such changes include but are not limited to addition, removal, or modification of ferrous or electrically conductive materials located in the same wing as a GMU magnetometer unit. This procedure validates that no electronic device is interfering with the operation of the GMU magnetometer which directly impacts the determination of attitude and heading by the GSU 25D. The ADAHRS Unit Orientation and Pitch/Roll Offset Compensation are not required prior to this execution of this procedure. A sequence of activities to be performed during a magnetometer interference test is shown in Table 5-7 below. This is an example to help guide a technician through an aircraft's functions that may create interference with an installed GMU 11 magnetometer.



**CAUTION**

The real time readout displayed during the interference test is only valid for the location of the GMU when the test was initiated. If using this procedure to evaluate multiple mounting locations, the test must be started over for each location, failure to do so could provide incorrect test results.

1. Power on PFD in configuration mode (Section 3.2.2).
2. Select the Magnetometer Calibration Page.
3. Select Magnetic Interference Test.
4. Ensure that the aircraft has been properly prepared per the on-screen instructions. See Table 5-7 for a sample test sequence. Press the Start button to begin the test.

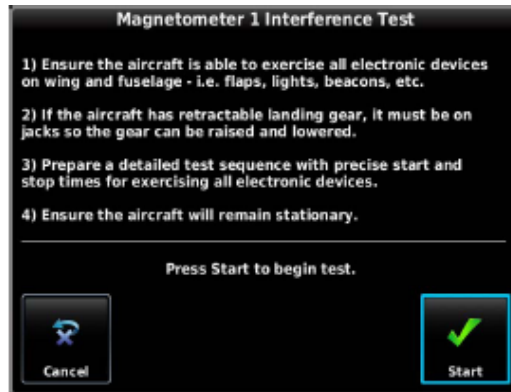

**Figure 5-6 – Magnetometer Interference Test On-screen Instructions**

5. The actions must be carried out as called for in the prepared test sequence. During calibration, a real-time value is displayed that represents the current magnetic field strength as a percentage of the maximum limit.

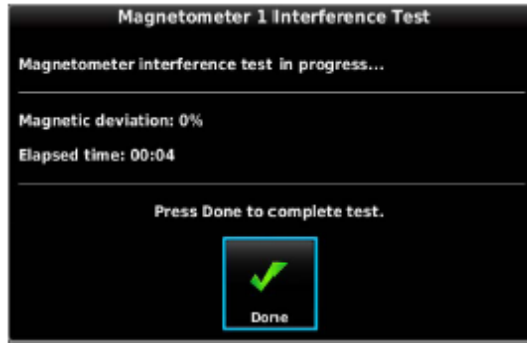

Figure 5-7 – Magnetometer Interference Test Progress



**NOTE**

*It is important that all actions are carried out in the order and at the precise elapsed time as specified in the prepared test sequence.*

6. After completing the prepared test sequence, press the Done softkey. Ensure that a PASSED message appears on the display. The magnetic deviation value is displayed to indicate the pass or fail margin of the test. Press the Done softkey to return to the Magnetometer Page.

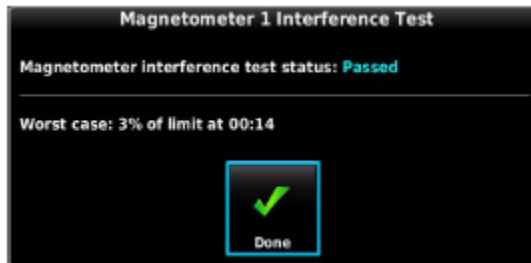

Figure 5-8 – Magnetometer Interference Test Status

**Table 5-7 – Magnetometer Interference Test Sequence Example**

<b>Elapsed Time (From Start of Test) (min:secs)</b>	<b>Action</b>
0:00	Test Begins
0:10	Aileron Full Right
0:20	Aileron Full Left
0:30	Aileron Level
0:40	Elevator Up
0:50	Elevator Down
1:00	Elevator Level
1:20	Rudder Left
1:40	Rudder Right
1:50	Rudder Center
2:00	Flaps Down
2:10	Flaps Up
2:20	Autopilot On
2:30	Autopilot Off
2:40	Electric Trim (GFC 500)
2:50	Landing Gear Up
3:00	Landing Gear Down
3:10	Speed Brake Up
3:20	Speed Brake Down
3:30	Navigation Lights On
3:40	Navigation Lights Off
3:50	Landing Lights On
4:00	Landing Lights Off
4:10	Taxi Lights On
4:20	Taxi Lights Off
4:30	Landing + Taxi Lights On
4:40	Landing + Taxi Lights Off
4:50	Strobes On
5:00	Strobes Off
5:10	Recognition Lights On
5:20	Recognition Lights Off
5:30	All Wing-Tip Lights On (simultaneous)
5:40	All Wing-Tip Lights Off (simultaneous)
5:50	Beacon On
6:00	Beacon Off
6:10	Pitot Heat On
6:20	Pitot Heat Off
6:30	Test Complete

If the magnetic interference test fails, the installation should be considered unreliable until the source of magnetic interference is identified and remedied. The magnetometer interference test must be repeated until passed. When the magnetometer interference test fails, record the magnetometer maximum deviation values, and the corresponding timestamps. A maximum deviation value greater than 100% of the total limit in any axis indicates a problem that must be resolved. Compare the corresponding timestamps with the prepared test sequence to identify which action produced the problem. Contact Garmin for assistance in resolving the problem.



**NOTE**

*Common reasons for a failed magnetometer interference test are:*

- *new equipment is installed in close proximity to the GMU magnetometer or*
- *An existing or new electronic device has become grounded through the aircraft structure instead of by proper ground wire in a twisted shielded pair, or*
- *Use of magnetized tools in close proximity to the GMU 11.*

**5.5 Engine Indication Troubleshooting**

EIS indication failures may be presented as red x's on the gauges as shown in Figure 5-9, or as operation anomalies. Reference Table 5-8 below for troubleshooting guidance.

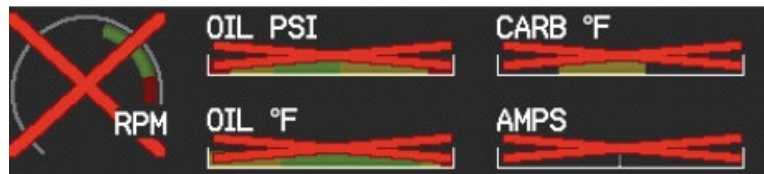

**Figure 5-9 – Engine/Airframe Failure Indications**

**Table 5-8 – EIS Gauges Troubleshooting**

Symptom or Failure Message	Possible Cause	Recommended Action
<b>EIS FAIL</b>	Power removed from GEA 24(B). Defective or failed GEA 24(B).	Ensure GEA 24(B) circuit breaker is not open. Inspect wiring and electrical connections. If problem persists, replace the GEA 24(B) with a known good unit.
Engine Indications Red X'd	Power interrupted during initialization.	Cycle power and permit time for initialization.
	Software and configuration load error.	Reload software.
EGT/CHT only Red X'd	Transient voltage (for example while cranking engine) on CHT 5 & 6 inputs, applicable only to GEA 24B Mod 0 installation with 6-cylinder engines.	Cycle GEA 24B circuit breaker and verify gauges return to normal. Problem may be resolved by reducing transient voltages, for example service the engine bonding strap connections and verify the engine start solenoid 'fly-back' diode is operational. If problem persists, replace GEA 24B Mod 0 with a GEA 24B Mod 1 (or later mod level).
	Temperature probe is shorted ( <i>typically where the bayonet is crimped</i> ).	Inspect temperature probe(s) and wiring.

Symptom or Failure Message	Possible Cause	Recommended Action
EGT temperature slowly drift up and eventually flag	Electrical open in the probe or wiring.	Inspect EGT probes and wiring.
Unstable RPM	Resistor failure.	Disconnect P-Lead signal wires at both ends. Verify wire is more than 400 KΩ. <ul style="list-style-type: none"> <li>Replace wire and parallel resistors if less than 400 KΩ</li> </ul>
	Poor connection.	Verify wiring and connections.
	Interference.	Route signal wires away from spark plug leads and power wires.
Unstable RPM during magneto check	Resistor failure.	Disconnect P-Lead signal wires at both ends. Verify wire is more than 400 KΩ. <ul style="list-style-type: none"> <li>Replace wire and parallel resistors if less than 400 KΩ.</li> </ul>
	Poor connection.	Verify wiring and connections.
RPM is erratic during engine start/cranking	Starting vibrator is installed. Normal operation with p-lead RPM input.	None.
Fuel quantity gauge is inaccurate	Poor connection.	Verify wiring and connections.
	Fuel probe malfunction.	Replace fuel probe.
	Probe out of calibration.	Recalibrate fuel tank probes
	Incorrect resistors installed in harness between GEA 24 and resistive fuel probe.	Comply with Garmin Service Bulletin 2134.
	Incorrect configuration setting for resistive fuel probe.	Verify correct configuration setting (reference section B.7 and G3X Installation Manual Rev. 14 or later).
	GEA 24 replaced by GEA 24B.	Verify configuration settings (reference section B.7 and G3X STC Installation Manual Rev. 14 or later) and recalibrate fuel tank probes.
Fuel totalizer inaccurate	Fuel flow requires calibration	Calibrate fuel flow. (1) Replace fuel flow transducer
Fuel flow indication is unstable	Poor connection.	Verify wiring and connections
	Air/contamination in the sensor.	Purge fuel lines of air, verify sensor orientation and clean the sensor.
	Interference.	Route wires away from spark plug leads and power wires. Install EMI shield. <ul style="list-style-type: none"> <li>Replace fuel flow transducer if symptoms persist</li> </ul>



Symptom or Failure Message	Possible Cause	Recommended Action
Manifold pressure unstable	Pressure line drain plugged.	Verify manifold pressure line vent (if installed) is clear. Verify fuel is not trapped in the manifold pressure line.
	Sensor failure.	Replace manifold pressure sensor.
	Pressure pulses from opening and closing valves in the intake manifold.	Install Garmin Restrictor p/n 117-02083-00 in accordance with G3X Touch AML STC Installation Manual 190-02472-01.
Manifold pressure inaccurate	Pressure line blocked.	Verify manifold pressure line and Garmin Restrictor (if installed) are clear of obstructions. Refer to Section 6.6.1.1.1 for cleaning procedure.
	Sensor failure.	Replace pressure manifold sensor.
Engine Interface configuration error	The GEA 24(B) has a configuration error.	Check GEA 24(B) configuration, calibration, and wiring. Verify compliance with Garmin Service Bulletin 2134.

**Notes:**

(1) Reference the G3X Touch EFIS Part 23 AML STC Installation Manual (190-02472-01)



**5.6 Traffic Alert Messages**

**Table 5-9 – Traffic Alert Troubleshooting**

Failure Message	Possible Cause	Recommended Action
	• Interface to the G3X has failed	Inspect unit wiring and connections for faults
	• Traffic device has failed	Troubleshoot the device failure in accordance with the LRU maintenance manual

**5.7 Transponder Alert Messages**

**Table 5-10 – Transponder Alert Troubleshooting**

Failure Message	Possible Cause	Recommended Action
	GPS data connection from external navigator lost	Verify ADS-B sourced GPS receiver has a GPS signal Verify external navigator has power and is functioning properly
"Red X'd" XPDR 	Transponder failure	Verify the transponder is powered on and functional.
	Communication lost between transponder and GSU 25D	Verify the GSU 25D is powered on and functional (the transponder communicates to G3X via the GSU).
XPDR Fault	Hardware fault	Contact Garmin Product Support
XPDR CONFIG ERROR	Transponder configuration fault	Check transponder configuration

Failure Message	Possible Cause	Recommended Action
NO ID	Flight ID is not defined correctly.	<ul style="list-style-type: none"> <li>✓ if “Set by Pilot” is configured, ensure the flight ID is an alpha numeric with eight or less characters.</li> <li>✓ If the flight ID was entered via GTX tool, correct it.</li> </ul>

### 5.8 Loss of Navigation Information (External Navigators)

If VHF/GPS Navigation information is removed from the G3X Touch GDU and “GPS” (in magenta) and “VFR” and “REV” (both in yellow) are displayed on the PFD HSI:

**Table 5-11 – Loss of Navigation Information (External Navigators)**

Failure Message	Possible Cause	Recommended Action
	Communication with external GPS lost. PFD automatically reverted to internal GPS	<ul style="list-style-type: none"> <li>• Complete troubleshooting as directed and applicable in Sections 5.1 (General Troubleshooting) and 5.2 (CAN bus troubleshooting).</li> <li>• Inspect and verify the ARINC 429 wiring between GPS navigator and GAD 29B/29D.</li> <li>• Verify the G3X Touch and GPS navigator configurations have not changed. Reference APPENDIX B</li> <li>• Verify navigator is functioning properly. Reference the navigator manufacturer’s troubleshooting procedures.</li> <li>• If problem persists, replace the GAD 29B or navigator as applicable with a known good unit.</li> </ul> <p><i>Contact Garmin Product Support before replacing unit to determine all troubleshooting options have been accomplished.</i></p>

### 5.9 Garmin GFC 500 Failure Messages

During operation of the GFC 500 AFCS, the G3X Touch GDU may annunciate a failure or fault that is specific to the GFC 500 Autopilot system. Refer to the *GFC 500 Autopilot with Electronic Stability Protection Part 23 AML STC Maintenance Manual with Instructions for Continued Airworthiness* (190-02291-01), for assistance in troubleshooting the problem.

### 5.10 Loss of Non-Garmin Autopilot Heading and/or Course Datum





If a Non-Garmin autopilot loses the capability to couple and track Heading and/or Course Datum:

1. Complete troubleshooting as directed and applicable in Sections 5.1, 5.2 (CAN bus troubleshooting), 5.4.2 (for loss of heading datum) and 5.10 (for loss of course and GPSS datum).
2. Inspect and verify the ARINC 429 wiring between GPS navigator, GAD 29B/29D and the autopilot computer.
3. Inspect the analog wiring between the GAD29B and the autopilot computer.

4. Verify the G3X Touch and GPS navigator configurations have not changed. Reference APPENDIX B
5. Verify autopilot computer is functioning properly. Reference the autopilot manufacturer's troubleshooting procedures.
6. If problem persists, replace the GAD 29B/29D with a known good unit.

### 5.11 Miscellaneous Alerts

**Table 5-12 – Miscellaneous Alerts**

Alert/Failure Message	Possible Cause	Recommended Action
TAWS FAIL	Database error Loss of GPS position	Verify databases are up to date Verify GPS signal is available
<b>ECS FAIL</b>	Power removed from GAD 27 Defective or failed GAD 27 Electrical Control System tab is configured as "Enabled" and the GAD 27 is powered off or failed.	Ensure GAD 27 circuit breaker is not open. Inspect wiring and electrical connections. If problem persists, replace the GAD 27 with a known good unit.
<b>CO FAIL</b>	Power lost from the CO detector Defective or failed CO detector.	Inspect CO detector wiring and electrical connections. Consult the CO detector manufacturer's data for troubleshooting guidance.
"Red X'd" COM or NAV 	Power removed from the COM or NAV radio Defective wiring or failed COM or NAV radio.	Ensure COM or NAV circuit breaker is not open. Inspect wiring and electrical connections.
"Red X'd" Audio Panel 	Power removed from the audio panel Defective wiring or failed Audio panel.	Ensure AUDIO circuit breaker is not open. Inspect wiring and electrical connections.
	GDU 470 display is in split screen mode and CAUTION annunciations are not displayed.	<ul style="list-style-type: none"> <li>✓ Select full screen format to view messages</li> <li>✓ Select <b>Messages</b> on the lower section of the display</li> </ul>
	GDU 470 display is in split screen mode and WARNING annunciations are not displayed.	

### 5.12 Aircraft Harness/LRU Connectors

This section describes the aircraft harness connectors and associated LRU connectors. The pin arrangement for each LRU connector is shown and the LRU connector arrangement for units with more than one connector will be shown in the following sections. LRU connector arrangements will show the aircraft harness connector designations. Reference the *G3X Touch EFIS Part 23 AML STC Installation Manual (190-02472-01)* for further detail.

### 5.12.1 GDU 4X0 Aircraft Harness/LRU Connectors

This section describes the GDU 4X0 aircraft harness and interface connectors on the GDU. The GDU connector designation is P4X01 and P4X02 and the aircraft harness connectors are designated as J4X01 and J4X02 respectively. GDU connector P4X03 is not used. The GDU connectors are clearly marked on the back of the GDU as P4601, P4602 and P4603 for GDU 460 and P4701, P4702, and P4703 for GDU 470.

#### 5.12.1.1 Aircraft Harness Connector J4X01

The aircraft harness connector J4X01 is a 9-socket D-sub plug connector and interfaces to the GDU P4X01 connector. A pinout arrangement of P4X01 is shown in Figure 5-10. Connector pin functions are shown in Table 5-13.

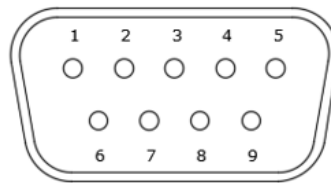

**Figure 5-10 – View of P4X01 Connector from back of GDU**

**Table 5-13 – P4X01/J4X01 Pin Functions**

PIN	PIN NAME	I/O
1	RESERVED	--
2	RESERVED	--
3	RESERVED	--
4	RS-232 TX	OUT
5	RS-232 RX	IN
6	RESERVED	--
7	RESERVED	--
8	RESERVED	--
9	RS-232 GROUND	--

#### 5.12.1.2 Aircraft Harness Connector J4X02

The aircraft harness connector J4X02 is a 50-pin D-sub plug connector and interfaces to the GDU P4X02 connector. A pinout arrangement of P4X02 is shown in Figure 5-11 and connector pin functions are shown in Table 5-14

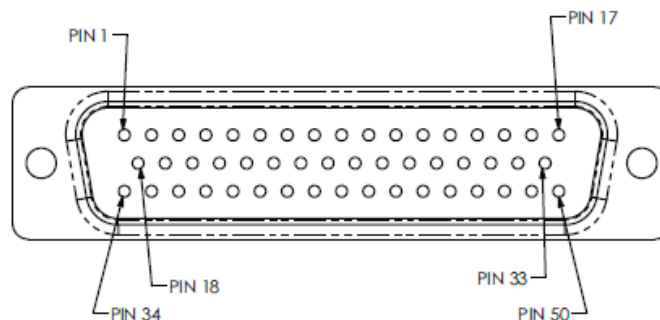

**Figure 5-11 – View of P4X02 Connector from back of GDU**

**Table 5-14 – P4X02/J4X02 Pin Functions**

PIN	PIN NAME	I/O
1	ALERT AUDIO OUT HI	OUT
2	RESERVED	--
3	RESERVED	--
4	RESERVED	--
5	RESERVED	--
6	RESERVED	--
7	RESERVED	--
8	RESERVED	--
9	CDU SYSTEM ID PROGRAM 2	--
10	CDU SYSTEM ID PROGRAM 1	--
11	RESERVED	--
12	RESERVED	--
13	RS-232 TX 3	OUT
14	RS-232 RX 2	IN
15	RESERVED	--
16	POWER GROUND 1	--
17	CONFIG MODULE POWER OUT	OUT
18	ALERT AUDIO OUT LO	OUT
19	RESERVED	--
20	RESERVED	--
21	RESERVED	--
22	RESERVED	--
23	RS-232 RX 4	IN
24	RS-232 RX 5	IN
25	RESERVED	--
26	28V LIGHTING BUS HI	IN
27	SYSTEM PROGRAM GROUND	--
28	CAN BUS TERMINATION	--
29	RS-232 RX 3	IN
30	RS-232 TX 2	OUT
31	AIRCRAFT POWER 2	--
32	AIRCRAFT POWER 1	--
33	CONFIG MODULE CLOCK	I/O
34	RS-232 GROUND 1	--
35	RS-232 GROUND 2	--
36	RS-232 GROUND 3	--
37	RS-232 GROUND 4	--
38	RESERVED	--
39	RESERVED	--
40	RS-232 TX 4	OUT
41	RS-232 TX 5	OUT
42	RESERVED	--
43	14V LIGHTING BUS HI	IN
44	RS-232 GROUND 5	--
45	CAN-L	I/O
46	CAN-H	I/O
47	RS-232 RX 1	IN
48	RS-232 TX 1	OUT
49	CONFIG MODULE GROUND	--
50	CONFIG MODULE DATA	I/O

**5.12.2 GSU 25D Aircraft Harness/LRU Connectors**

This section describes the GSU 25D aircraft harness and interface connectors on the GSU. The GSU connector designation is J251 and J252 and the aircraft harness connectors are designated as P251 and P252 respectively.

**5.12.2.1 Aircraft Harness Connector P251**

The aircraft harness connector P251 is a 9-socket D-sub plug connector and interfaces to the J251 connector on the GSU. A pinout arrangement of J251 is shown in Figure 5-12 and connector pin functions are shown in Table 5-15.

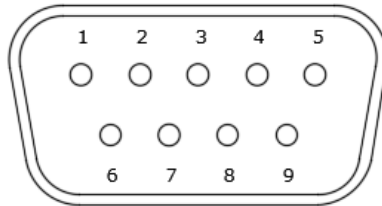

**Figure 5-12 – View of J251 Connector on the GSU 25D**

**Table 5-15 – P251/J251 Pin Functions**

Pin	Pin Name	I/O
1	CAN-H	I/O
2	CAN-L	I/O
3	RESERVED	--
4	RS-232 RX 1	IN
5	RS-232 TX 1	OUT
6	POWER GROUND	--
7	AIRCRAFT POWER 1	IN
8	AIRCRAFT POWER 2	IN
9	RS-232 GROUND	--

**5.12.2.2 Aircraft Harness Connector P252**

The aircraft harness connector P251 is a 15-socket D-sub plug connector and interfaces to the J251 connector on the GSU. A pinout arrangement of J251 is shown in Figure 5-13 and connector pin functions are shown in Table 5-16.

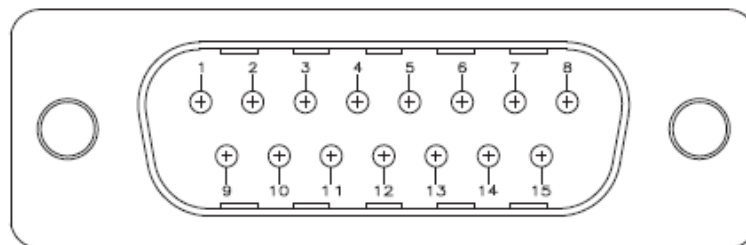

**Figure 5-13 – View of J252 Connector on the GSU 25D**

**Table 5-16 – P252/J252 Pin Functions**

PIN	PIN NAME	I/O
1	TEMP PROBE POWER OUT	OUT
2	TEMP PROBE IN HI	IN
3	TEMP PROBE IN LO	IN
4	RESERVED	--
5	RESERVED	--
6	RESERVED	--
7	RESERVED	--
8	RESERVED	--
9	RS-232 TX 3	OUT
10	RS-232 RX 3	IN
11	RS-232 GROUND 3	--
12	RESERVED	--
13	RESERVED	--
14	RS-232 GROUND 2	--
15	RS-232 TX 2	OUT

**5.12.3 GMU 11 Aircraft Harness/LRU Connector**

This section describes the GMU 11 aircraft harness and interface connector. The GMU LRU connector designation is J111 and the aircraft harness connector is designated as P111.

The aircraft harness connector P111 is a 9-socket D-sub plug connector and interfaces to the J111 connector on the GMU. A pinout arrangement of J111 is shown in Figure 5-14 and connector pin functions are shown in Table 5-17.

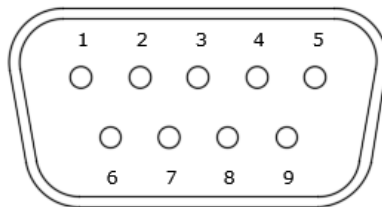

**Figure 5-14 – View of J111 Connector on the GMU 11**

**Table 5-17 – P111/J111 Pin Functions**

Pin	Pin Name	I/O
1	CAN-H	I/O
2	CAN-L	I/O
3	RESERVED	--
4	RESERVED	--
5	RESERVED	--
6	RESERVED	--
7	AIRCRAFT POWER 1	IN
8	AIRCRAFT POWER 2	IN
9	POWER GROUND	--

**5.12.4 GTP 59 Harness**

The GTP59 is an OAT sensing device. The connection to this LRU is made via pre-installed lead wires and it is acceptable to use crimp splices to extend the lead wire harness to the GSU. The pre-installed lead wires are ten feet in length. Reference Table 5-18 for lead wire functions. For specific wiring information refer to *G3X Touch EFIS Part 23 AML STC Installation Manual (190-02472-01)*.

**Table 5-18 – GTP 59 Lead Wire Functions**

PIN	WIRE	I/O
WHITE	TEMP PROBE POWER IN	IN
BLUE	TEMP PROBE OUT HI	OUT
ORANGE	TEMP PROBE OUT LO	OUT

**5.12.5 GAD 27 Aircraft Harness/LRU Connectors**

This section describes the GAD 27 aircraft harness and the interface connectors on the GAD 27. The GAD 27 connector designation is J271 and the aircraft harness connector is designated as P271. GAD 27 connector J272 is not used. GAD 27 also has a terminal block TB273.

**5.12.5.1 Aircraft Harness Connector P271**

The aircraft harness connector P271 is a 50-socket D-sub plug connector and interfaces to the GAD 27 connector J271. A pinout arrangement of J271 is shown in Figure 5-15 and connector pin functions are shown in Table 5-19.

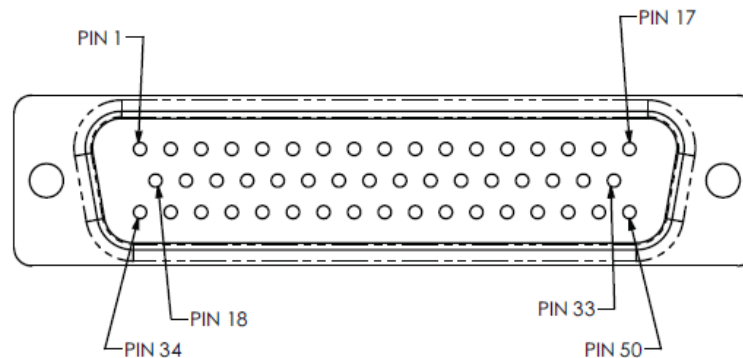

**Figure 5-15 – View of J271 Connector on the GAD 27**

**Table 5-19 – P271/J271 Pin Functions**

PIN	PIN NAME/FUNCTION	I/O
1	CAN HI	I/O
2	CAN LO	I/O
3	CAN BUS TERM	--
4	GAD 27 POWER GND	--
5	RESERVED	--
6	RESERVED	--
7	GAD 27 POWER	IN
8	GAD 27 POWER GROUND	--
9	RESERVED	--
10	RESERVED	--
11	RESERVED	--
12	RESERVED	--



PIN	PIN NAME/FUNCTION	I/O
13	RESERVED	--
14	RESERVED	--
15	RESERVED	--
16	RESERVED	--
17	RESERVED	--
18	RESERVED	--
19	RESERVED	--
20	RESERVED	--
21	RESERVED	--
22	RESERVED	--
23	RESERVED	--
24	RESERVED	--
25	RESERVED	--
26	RESERVED	--
27	RESERVED	--
28	RESERVED	--
29	RESERVED	--
30	RESERVED	--
31	RESERVED	--
32	RESERVED	--
33	RESERVED	--
34	LIGHT 1 SWITCH	IN
35	LIGHT 2 SWITCH	IN
36	ALTERNATING FLASH ON	IN
37	RESERVED	--
38	GAD 27 POWER GROUND	--
39	RESERVED	--
40	RESERVED	--
41	RESERVED	--
42	RESERVED	--
43	RESERVED	--
44	RESERVED	--
45	RESERVED	--
46	RESERVED	--
47	RESERVED	--
48	RESERVED	--
49	RESERVED	--
50	RESERVED	--

**5.12.5.2 Terminal Block TB273**

This connection is only required for 14 VDC aircraft using p/n 235-00094-00 ring terminal. A terminal arrangement of TB273 is shown in Figure 5-16 and connector terminal functions are shown in Table 5-20

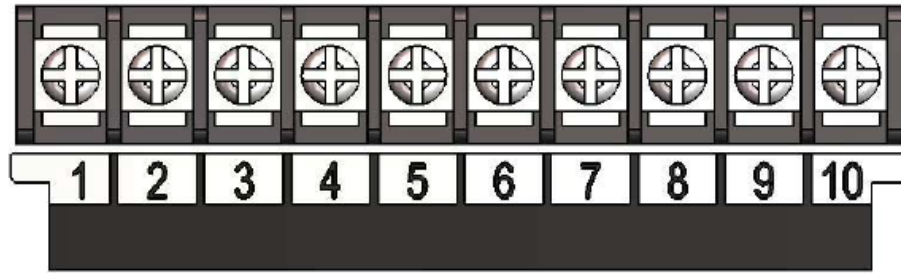

Figure 5-16 – View of TB273 Terminal Block on GAD 27

Table 5-20 – TB273 Terminal Functions

TERMINAL	TERMINAL NAME/FUNCTION	I/O
1	KEEP ALIVE POWER IN	IN
2	KEEP ALIVE POWER V OUT	OUT
3	LIGHT 1 POWER IN	IN
4	LIGHT 2 POWER IN	IN
5	RESERVED	--
6	RESERVED	--
7	RESERVED	--
8	RESERVED	--
9	LIGHT 1 POWER OUT	OUT
10	LIGHT 2 POWER OUT	OUT

### 5.12.6 GEA 24(B) Aircraft Harness/LRU Connectors

This section describes the GEA 24(B) aircraft harness and LRU interface connectors. The GEA connector designations are J241, J242, J243 and J244 and the aircraft harness connectors are designated as P241, P242, P243 and P244 respectively.

#### 5.12.6.1 Aircraft Harness Connectors P241

The aircraft harness connector P241 is a 9-socket D-sub plug connector and interfaces to the J241 connector on the GEA. A pinout arrangement of J241 is shown in Figure 5-17 and connector pin functions are shown in Table 5-21.

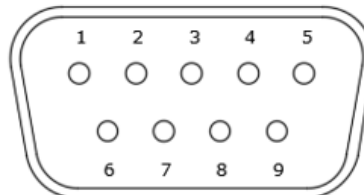

Figure 5-17 – View of J241 Connector on the GEA 24(B)

Table 5-21 – P241/J241 Pin Functions

PIN	PIN NAME	I/O
1	CAN HI	I/O
2	CAN LO	I/O
3	RESERVED	--

PIN	PIN NAME	I/O
4	RS-232 RX 1	IN
5	RS-232 TX 1	OUT
6	POWER GROUND	--
7	AIRCRAFT POWER 1	--
8	AIRCRAFT POWER 2	--
9	RS-232 GROUND	--

### 5.12.6.2 Aircraft Harness Connectors P242

The aircraft harness connector P242 is a 25-pin D-sub plug connector and interfaces to the J242 connector on the GEA. A pinout arrangement of J242 is shown in Figure 5-18 and connector pin functions are shown in Table 5-22

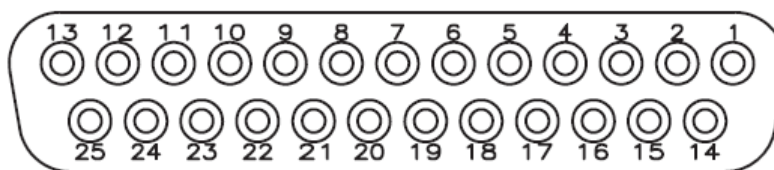

Figure 5-18 – View of J242 Connector on the GEA 24(B)

Table 5-22 – P242/J242 Pin Functions

PIN	PIN NAME	I/O
1	RESERVED	--
2	CHT CYL 6 LO	IN
3	EGT CYL 6 LO	IN
4	CHT CYL 5 LO	IN
5	EGT CYL 5 LO	IN
6	CHT CYL 4 LO	IN
7	EGT CYL 4 LO	IN
8	CHT CYL 3 LO	IN
9	EGT CYL 3 LO	IN
10	CHT CYL 2 LO	IN
11	EGT CYL 2 LO	IN
12	CHT CYL 1 LO	IN
13	EGT CYL 1 LO	IN
14	CHT CYL 6 HI	OUT
15	EGT CYL 6 HI	OUT
16	CHT CYL 5 HI	OUT
17	EGT CYL 5 HI	OUT
18	CHT CYL 4 HI	OUT
19	EGT CYL 4 HI	OUT
20	CHT CYL 3 HI	OUT
21	EGT CYL 3 HI	OUT
22	CHT CYL 2 HI	OUT
23	EGT CYL 2 HI	OUT
24	CHT CYL 1 HI	OUT
25	EGT CYL 1 HI	OUT

**5.12.6.3 Aircraft Harness Connector P243**

The aircraft harness connector P243 is a 37-socket D-sub plug connector and interfaces to the J243 connector on the GEA. A pinout arrangement of J243 is shown in Figure 5-19 and connector pin functions are shown in Table 5-23.

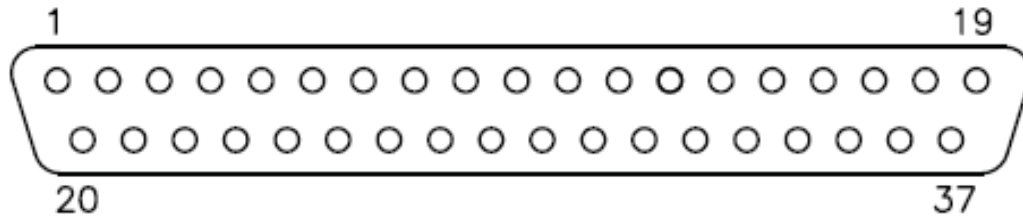

**Figure 5-19 – View of J243 Connector on the GEA 24(B)**

**Table 5-23 – P243/J243 Pin Functions**

PIN	PIN NAME	I/O
1	FUEL PRESS GND	--
2	FUEL PRESS RX	IN
3	FUEL PRESS XDCR +12V	OUT
4	FUEL PRESS XDCR +5V	OUT
5	RPM 2 GND	--
6	RPM 2	IN
7	RPM 1 GND	--
8	RPM 1	IN
9	RPM 1 +12V	OUT
10	RPM 2 +12V	OUT
11	RESERVED	--
12	MANIFOLD PRESS GND	--
13	MANIFOLD PRESS RX	IN
14	MANIFOLD PRESS XDCR +12V	OUT
15	MANIFOLD PRESS XDCR +5V	OUT
16	OIL PRESS GND	--
17	OIL PRESS RX	IN
18	OIL PRESS XDCR +12V	OUT
19	OIL PRESS XDCR +5V	OUT
20	FUEL FLOW 1 GND	--
21	FUEL FLOW 2 RX	IN
22	FUEL FLOW 2 GND	--
23	FUEL FLOW 1 RX	IN
24	FUEL FLOW 1 XDCR +12V	OUT
25	FUEL FLOW 2 XDCR +12V	OUT
26	RESERVED	--
27	RESERVED	--
28	TIT 2 LO	IN
29	TIT 2 HI	IN
30	TIT 1 LO or CARBURETOR TEMP LO	IN
31	TIT 1 HI or CARBURETOR TEMP HI	IN
32	OIL TEMP LO	IN
33	OIL TEMP HI	IN
34	BUS 2 AMPS LO	IN
35	BUS 2 AMPS HI	IN
36	BUS 1 AMPS LO	IN
37	BUS 1 AMPS HI	IN

### 5.12.6.4 Aircraft Harness Connector P244

The aircraft harness connector P244 is a 50-socket D-sub plug connector and interfaces to the J244 connector on the GEA. A pinout arrangement of J244 is shown in Figure 5-20 and connector pin functions are shown in Table 5-24

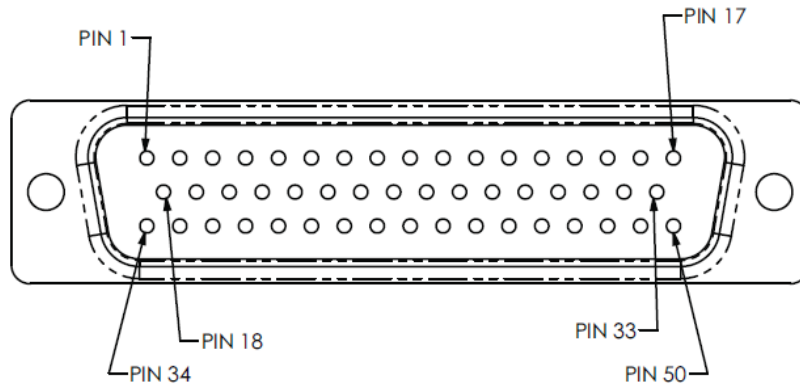

Figure 5-20 – View of J244 Connector on the GEA 24(B)

Table 5-24 – P244/J244 Pin Functions

PIN	PIN NAME	I/O
1	RESERVED	--
2	RESERVED	--
3	RESERVED	--
4	RESERVED	--
5	RESERVED	--
6	FUEL QTY 1	IN
7	RESERVED	--
8	RESERVED	--
9	FUEL QTY 2	IN
10	RESERVED	--
11	RESERVED	--
12	FUEL QTY 3	IN
13	RESERVED	--
14	RESERVED	--
15	FUEL QTY 4	IN
16	RESERVED	--
17	RESERVED	--
18	RESERVED	--
19	RESERVED	--
20	RESERVED	--
21	RESERVED	--
22	RESERVED	--
23	RESERVED	--
24	RESERVED	--
25	VOLTS 1	IN
26	RESERVED	--
27	RESERVED	--
28	VOLTS 2	IN
29	RESERVED	--
30	RESERVED	--
31	RESERVED	--

PIN	PIN NAME	I/O
32	RESERVED	--
33	RESERVED	--
34	FUEL QUANTITY 1 XDCR +12V	OUT
35	FUEL QUANTITY 2 XDCR +12V	OUT
36	RESERVED	--
37	RESERVED	--
38	RESERVED	--
39	RESERVED	--
40	RESERVED	--
41	RESERVED	--
42	RESERVED	--
43	RESERVED	--
44	MASTER WARNING	IN
45	MASTER CAUTION	IN
46	RESERVED	--
47	RESERVED	--
48	RESERVED	--
49	RESERVED	--
50	FUEL QUANTITY 3 & 4 XDCR +12V	OUT

### 5.12.7 GAD 29B/29D Aircraft Harness/LRU Connectors

This section describes the GAD 29B/29D aircraft harness and LRU interface connectors. The GAD 29 connector designations are J291 and J292 and the aircraft harness connectors are designated as P291 and P292 respectively.

#### 5.12.7.1 Aircraft Harness Connector P291

The aircraft harness connector P291 is a 9-socket D-sub plug connector and interfaces to the J291 connector on the GAD29B. A pinout arrangement of J291 is shown in Figure 5-21 and connector pin functions are shown in Table 5-25.

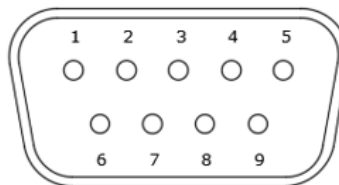

Figure 5-21 – View of J291 Connector on the GAD 29B/29D

Table 5-25 – P291/J291 Pin Functions

PIN	PIN NAME	I/O
1	CAN-H	I/O
2	CAN-L	I/O
3	RESERVED	--
4	RESERVED	--
5	RESERVED	--
6	POWER GROUND	--
7	AIRCRAFT POWER 1	IN
8	AIRCRAFT POWER 2	IN
9	GROUND	--

**5.12.7.2 Aircraft Harness Connector P292**

The aircraft harness connector P292 is a 25-pin D-sub plug connector and interfaces to the J291 connector on the GAD29B. A pinout arrangement of J292 is shown in Figure 5-22 and connector pin functions are shown in Table 5-26.

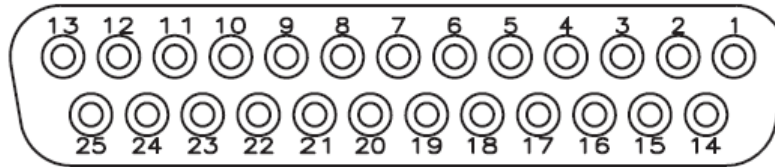

**Figure 5-22 – View of J292 Connector on the GAD 29B/29D**

**Table 5-26 – P292/J292 Pin Functions**

PIN	PIN NAME	I/O
1	AC REFERENCE HI	IN
2	AC REFERENCE LO	IN
3	HDG/CRS VALID	OUT
4	ARINC 429 RX 4B	IN
5	ARINC 429 RX 3B	IN
6	ARINC 429 TX 2B	OUT
7	ARINC 429 TX 2B	OUT
8	HEADING ERROR HI	OUT
9	CAN TERM 1	--
10	ARINC 429 RX 2B	IN
11	ARINC 429 RX 1B	IN
12	ARINC 429 TX 1B	OUT
13	ARINC 429 TX 1B	OUT
14	HEADING ERROR LO	IN
15	COURSE ERROR HI	OUT
16	ARINC 429 RX 4A	IN
17	ARINC 429 RX 3A	IN
18	ARINC 429 TX 2A	OUT
19	ARINC 429 TX 2A	OUT
20	COURSE ERROR LO	IN
21	CAN TERM 2	--
22	ARINC 429 RX 2A	IN
23	ARINC 429 RX 1A	IN
24	ARINC 429 TX 1A	OUT
25	ARINC 429 TX 1A	OUT

**5.12.8 GDL 5XR Aircraft Harness/LRU Connectors**

This section describes the GDL 5XR aircraft harness and interface connector. The GDL LRU connector designation is J5X1 and the aircraft harness connector is designated as P5X1.

The aircraft harness connector P5X1 is a 15-socket D-sub plug connector and interfaces to the J5X1 connector on the GMU. A pinout arrangement of J5X1 is shown in Figure 5-23 and connector pin functions are shown in Table 5-27.

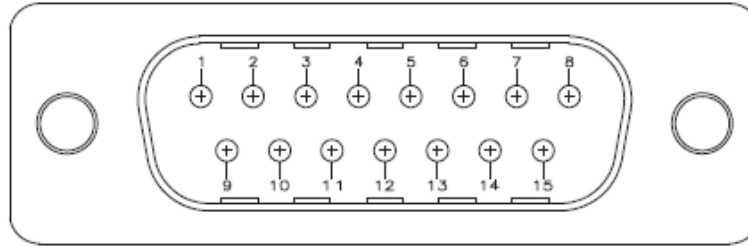

Figure 5-23 – View of J5X1 Connector on the GDL 5XR

Table 5-27 – P5X1/J5X1 Pin Functions

PIN	PIN NAME	I/O
1	RESERVED	--
2	RESERVED	--
3	RESERVED	--
4	RESERVED	--
5	RS-232 TX 2	OUT
6	RS-232 RX 2	IN
7	RS-232 TX 1	OUT
8	RS-232 RX 1	IN
9	POWER GROUND	--
10	AIRCRAFT POWER	IN
11	RS-232 GROUND 1	--
12	RS-232 GROUND 2	--
13	MUSIC OUT LEFT	OUT
14	AUDIO COMMON	--
15	MUSIC OUT RIGHT	OUT

### 5.12.9 GTR 20/200B Aircraft Harness/LRU Connector

This section describes the GTR 20 or GTR 200B aircraft harness and LRU interface connectors. The GTR connector designation is J2001 and the aircraft harness connector is designated as P2001.

The aircraft harness connector P2001 is a 37 socket D-sub plug connector and interfaces to the J2001 connector on the GTR 20 or GTR 200B. A pinout arrangement of J2001 is shown in Figure 5-24 and connector pin functions are shown in Table 5-28.

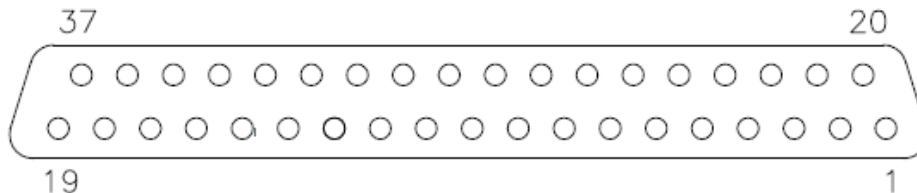

Figure 5-24 – View of J2001 Connector on GTR 20 or GTR 200B

Table 5-28 – P2001/J2001 Pin Functions

PIN	PIN NAME	I/O
1	AIRCRAFT POWER	IN
2	RESERVED	--
3	LIGHTING BUS	IN



PIN	PIN NAME	I/O
4	TRANSMIT INTERLOCK OUT*	OUT
5	TRANSMIT INTERLOCK IN*	IN
6	CAN-L	I/O
7	CAN-H	I/O
8	ID IN	--
9	AUX 2 AUDIO IN HI	IN
10	SUMMED AUDIO OUT HI	OUT
11	COPILOT HEADSET RIGHT	OUT
12	COPILOT HEADSET LEFT	OUT
13	PILOT HEADSET RIGHT	OUT
14	PILOT HEADSET LEFT	OUT
15	COPILOT PTT IN*	--
16	COPILOT MIC AUDIO IN HI	IN
17	PILOT MIC AUDIO IN HI	OUT
18	MUSIC 1 IN RIGHT	IN
19	MUSIC 1 IN LEFT	IN
20	AIRCRAFT GROUND	--
21	RESERVED	--
22	RESERVED	--
23	RESERVED	--
24	RESERVED	--
25	CAN TERM 2	--
26	CAN TERM 1	--
27	ID LO	--
28	AUX 2 AUDIO IN LO	--
29	SUMMED AUDIO OUT LO	OUT
30	COPILOT HEADSET LO	--
31	AUX 1 AUDIO IN LO	IN
32	AUX 1 AUDIO IN HI	IN
33	PILOT HEADSET LO	--
34	COPILOT MIC AUDIO IN LO	IN
35	PILOT PTT IN*	IN
36	PILOT MIC AUDIO IN LO	IN
37	MUSIC IN LO	--

### 5.12.10 GMA 245R Aircraft Harness/LRU Connectors

This section describes the GMA 245R with Marker Beacon aircraft harness and LRU interface connectors. The GMA connector designations are J2401 and J2402 and the aircraft harness connectors are designated as P2401 and P2402 respectively.

#### 5.12.10.1 Aircraft Harness Connector P2401

The aircraft harness connector P2401 is a 44-pin D-sub plug connector and interfaces to the J2401 connector on the GMA 245R. A pinout arrangement of J2401 is shown in Figure 5-25 and connector pin functions are shown in Table 5-29.

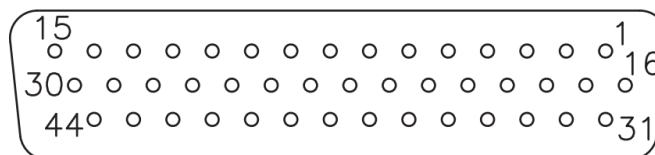

Figure 5-25 – View of J2401 Connector on GMA 245R

**Table 5-29 – P2401/J2401 Pin Functions**

PIN	PIN NAME	I/O
1	MARKER ANTENNA HI	IN
2	MARKER ANTENNA LO	IN
3	TEL AUDIO IN HI	IN
4	TEL AUDIO LO	--
5	TEL MIC AUDIO OUT HI	OUT
6	RESERVED	--
7	AUX 2 AUDIO IN HI	IN
8	AUX 2 AUDIO IN LO	--
9	COM 1 AUDIO IN HI	IN
10	COM 1 AUDIO LO	--
11	COM 1 MIC AUDIO OUT HI	OUT
12	COM 1 MIC KEY OUT	OUT
13	COM 2 AUDIO IN HI	IN
14	COM 2 AUDIO LO	--
15	COM 2 MIC AUDIO OUT HI	OUT
16	PILOT ICS KEY IN*	IN
17	NAV 1 AUDIO IN HI	IN
18	NAV 1 AUDIO IN LO	IN
19	NAV 2 AUDIO IN HI	IN
20	NAV 2 AUDIO IN LO	IN
21	AUX 1 AUDIO IN HI	IN
22	AUX 1 AUDIO IN LO	IN
23	AUX 3 AUDIO IN HI	IN
24	COM ACTIVE OUT*	OUT
25	RESERVED	--
26	RESERVED	--
27	RESERVED	--
28	RESERVED	--
29	ALERT 3 AUDIO IN HI	IN
30	COM 2 MIC KEY OUT*	OUT
31	ALERT 1 AUDIO IN HI	IN
32	ALERT 1 AUDIO IN LO	IN
33	PILOT MIC AUDIO IN HI	IN
34	PILOT MIC KEY IN*	IN
35	PILOT MIC AUDIO IN LO	IN
36	CAN-H	I/O
37	CAN-L	I/O
38	RESERVED	--
39	RESERVED	--
40	PASS HEADSET LEFT	OUT
41	PASS HEADSET RIGHT	OUT
42	PASS HEADSET LO	--
43	AUX 3, ALERT 3, 4 AUDIO LO	--
44	ALERT 4 AUDIO IN HI	IN

**5.12.10.2 Aircraft Harness Connector P2402**

The aircraft harness connector P2401 is a 44-pin D-sub plug connector and interfaces to the J2402 connector on the GMA 245R. A pinout arrangement of J2402 is shown in Figure 5-26 and connector pin functions are shown in Table 5-30.

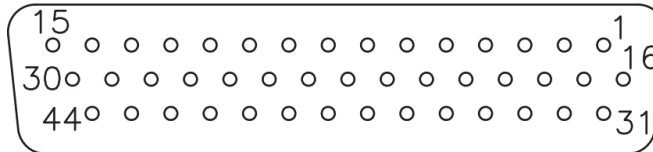

Figure 5-26 – View of J2402 Connector on GMA 245R

Table 5-30 – P2402/J2402 Pin Functions

PIN	PIN NAME	I/O
1	PILOT HEADSET LO	--
2	COPILOT HEADSET LO	--
3	COPILOT HEADSET LEFT	OUT
4	COPILOT HEADSET RIGHT	OUT
5	RESERVED	--
6	RESERVED	--
7	RESERVED	--
8	AIRCRAFT POWER 1	IN
9	RESERVED	--
10	POWER GROUND	--
11	RESERVED	--
12	RESERVED	--
13	PASSENGER ICS KEY IN*	IN
14	ALERT 2, FAILSAFE AUDIO LO	--
15	ALERT 2 AUDIO IN HI	IN
16	PILOT HEADSET LEFT	OUT
17	RESERVED	--
18	RESERVED	--
19	RESERVED	--
20	COM SWAP IN*	IN
21	RESERVED	--
22	PLAY KEY IN*	IN
23	MUSIC 1 IN LEFT	IN
24	MUSIC 1 IN RIGHT	IN
25	MUSIC 1 IN LO	--
26	MUSIC 2 IN LEFT	IN
27	MUSIC 2 IN RIGHT	IN
28	MUSIC 2 IN LO	--
29	FAILSAFE WARN AUDIO IN HI	IN
30	COPILOT ICS KEY IN*	IN
31	PILOT HEADSET RIGHT	OUT
32	COPILOT MIC AUDIO IN HI	IN
33	COPILOT MIC KEY IN*	IN
34	COPILOT MIC AUDIO IN LO	IN
35	PASS 1 MIC AUDIO IN HI	IN
36	PASS 1 MIC AUDIO IN LO	IN
37	PASS 2 MIC AUDIO IN HI	IN
38	PASS 2 MIC AUDIO IN LO	IN
39	PASS 3 MIC AUDIO IN HI	IN
40	PASS 3 MIC AUDIO IN LO	IN
41	PASS 4 MIC AUDIO IN HI	IN
42	PASS 4 MIC AUDIO IN LO	IN
43	CABIN SPEAKER OUT HI	OUT

PIN	PIN NAME	I/O
44	CABIN SPEAKER OUT LO	--

### 5.12.10.3 GMA 245R Dip Switch Configuration Settings

**Table 5-31 – GMA 245R DIP Switch Configuration Settings**

Switch	Function	Description
1	ENABLED KEYED ICS	When set to ON, the intercom system (ICS) will only allow intercom MIC audio to be heard when the corresponding ICS KEY for the MIC position is pressed. When set to ON, auto squelch will NOT be active.
2	PILOT IN RIGHT SEAT	This setting is for intercom 3D audio. Normally the Pilot will be positioned to the left in the Copilot's headset, and the Copilot will be positioned to the right in the Pilot's headset. When set to ON, this setting reverses that so the Pilot is positioned to the right in the Copilot's headset, and the Copilot is positioned to the left in the Pilot's headset.
3	MUTE ON COM TX	When set to ON, the monitored COM radio is muted during mic-selected COM transmission (mic-selected COM is still heard, but not the monitored COM radio).
4	RESERVED	LEAVE SWITCH IN OFF POSITION
5	RESERVED	LEAVE SWITCH IN OFF POSITION
6	RESERVED	LEAVE SWITCH IN OFF POSITION
7	RESERVED	LEAVE SWITCH IN OFF POSITION
8	CONFIGURATION LOCKOUT	LEAVE SWITCH IN OFF POSITION

### 5.12.11 GAP 26 Harness

The GAP 26 is an Angle of Attack (AOA) probe. The connection to this LRU is made via pre-installed lead wires to an AOA switch and aircraft ground.

## 6. G3X EQUIPMENT REMOVAL & REINSTALLATION

This section contains basic procedures for removing and reinstalling G3X LRUs.

The G3X Touch EFIS equipment part numbers approved by STC SA01899WI are in the *G3X Touch EFIS Part 23 AML STC Installation Manual* (190-02472-01).



### NOTE

*Once an LRU is replaced, software loading, and testing is required. See Section 7 for the software loading and testing procedures for a replacement LRU.*



### CAUTION

*Always ensure aircraft power is off or LRU circuit breaker is open when removing and/or replacing an LRU. Unplug any auxiliary power supplies*



### NOTE

*Ensure all LRU mounting hardware removed is retained for reinstallation. If hardware needs to be replaced, reference *G3X Touch EFIS Part 23 AML STC Installation Manual* (190-02472-01) appropriate hardware part numbers.*

### 6.1 GDU 4X0

#### Removal:

1. Power OFF the aircraft to remove power from the GDU and other LRUs.
2. Using a 3/32" hex tool, rotate all four fasteners counter-clockwise to remove them.
3. Carefully remove the display from the panel.
4. While supporting the display, disconnect all connectors and the GSU 25D without disconnecting the pitot/static/AOA lines (if installed on back of GDU, as defined in Section 6.2).

#### Reinstallation:

1. Inspect the connector and pins (on the unit) for signs of damage.
2. While supporting the display, connect the connectors to the rear of the unit and GSU 25D if installed on the back of GDU (as defined in Section 6.2).
3. Carefully insert the display into the panel cutout and align fasteners with the corresponding holes. Do not use excessive force while inserting the display.
4. Using a 3/32" hex tool, insert screws and rotate clockwise to tighten and torque to 8 ±1 in-lbs. to secure display to the instrument panel.
5. Continue to section 7.1 for configuration and checkout procedures.

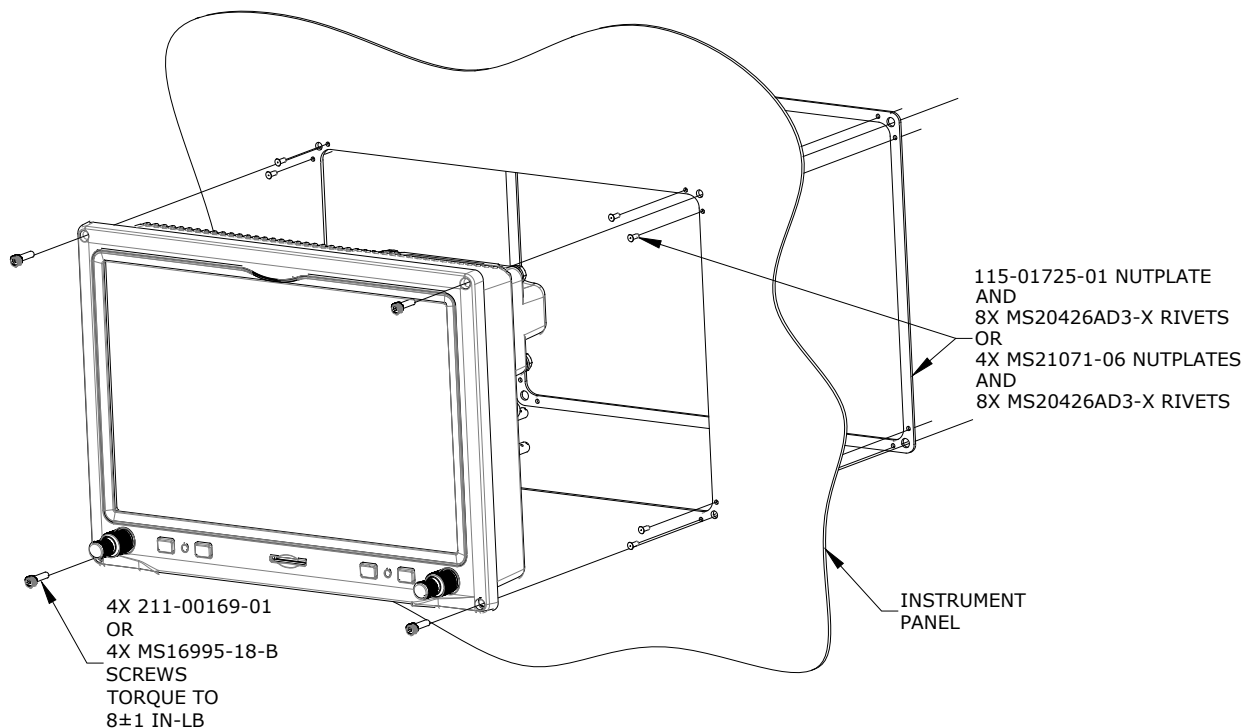

Figure 6-1 – GDU 460 Shown, (GDU 470 Similar)

### 6.1.1 PFD Configuration Module

The GDU 4X0 PFD display uses a configuration module designated as the master system configuration module. The master system configuration module stores configuration data identical to the PFD configuration data stored in the PFD memory. The PFD cross-checks the configuration module data against internal PFD memory and self-configures to match the master system configuration module. The PFD also maintains control of other LRUs' configuration and calibration settings such as the GSU 25D. This allows critical data to be retained with the airframe even if the PFD display is replaced.



**NOTE**

All item numbers (in parenthesis) in this procedure reference Figure 6-2.

**Removal:**

1. Remove the PFD in accordance with Section 6.1 to gain access to connector J4X02.
2. Remove the backshell cover (8) from connector J4X02 by removing the two screws (7).
3. Remove the screw (4) securing the configuration module (1) to the backshell (6).
4. Lift the configuration module (1) out of the backshell (6) and disconnect the wiring harness (3) from the module.
5. Inspect the wiring harness (3) and connector pins (2) for damage, loose wiring, or corrosion. Repair any defects or replace components as necessary.

**Reinstallation:**

1. Inspect the connectors to ensure there are no bent or damaged pins. Repair any damage.
2. Connect the wiring harness (3) to the new configuration module (1).
3. Install the new configuration module in the connector backshell (6) and secure with screw (4)
4. Reinstall the backshell cover (8) using the two screws (7).
5. Reconnect the J4X02 connector on the back of the GDU.
6. Reinstall the PFD in accordance with Section 6.1.

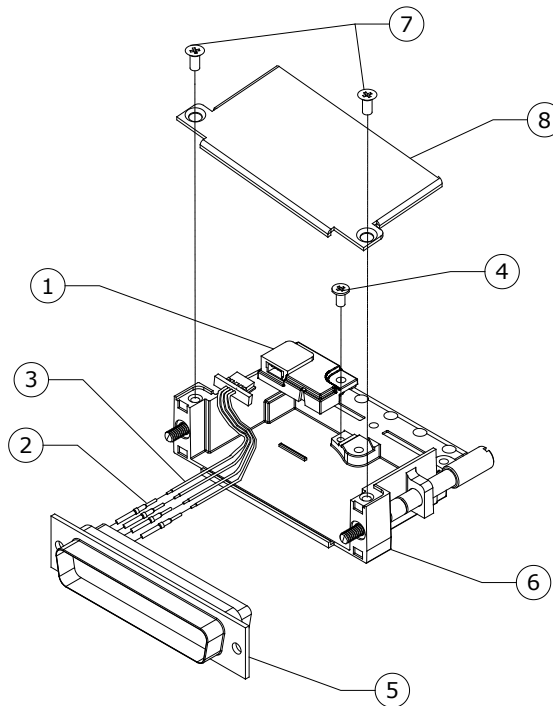

**Figure 6-2 – Configuration Module (PFD)**

**Table 6-1 – GDU Configuration Module Kit (P/N 010-12253-01)**

Item	Description	Qty. Required	Part Number
1	Potted Module (w/EEPROM)	1	011-03702-00
2	Contact, Socket, Size 20, 26-30 AWG	4	336-00022-01
3	4 conductor Config. Module harness	1	325-00122-00
4	Pan head screw	1	211-60232-07



**NOTE**

*System configuration will be automatically copied to the module by the PFD upon the first power ON after replacement. If the PFD was also replaced in conjunction with the module, system configuration and calibration will be required.*

**6.2 GSU 25D ADAHRS**

**Removal:**

**GDU-mounted GSU 25D:**

1. Remove the GDU in accordance with Section 6.1.
2. Disconnect the GSU 25D electrical connectors.
3. Disconnect the pitot, static, and AOA lines as required and install plugs or covers to protect the system.
4. While supporting the GSU 25D, remove the four bolts that attach the GSU 25D to the back of the GDU.

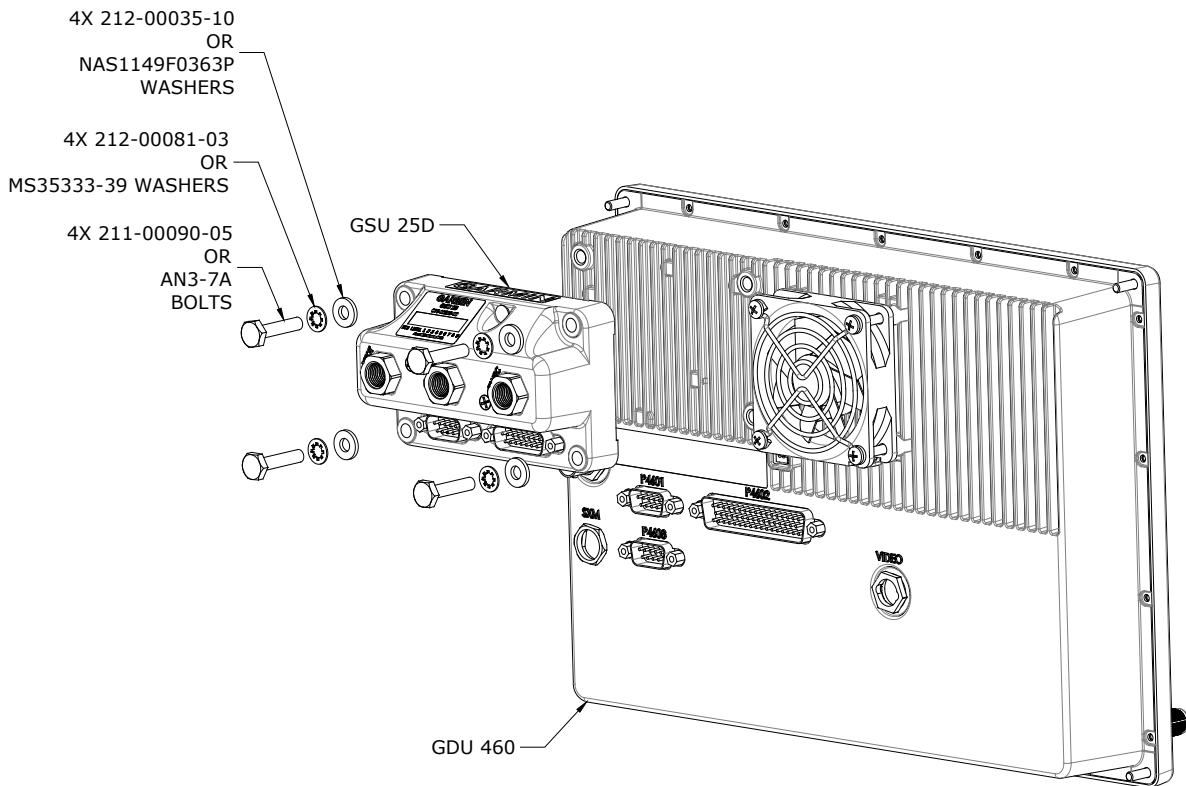
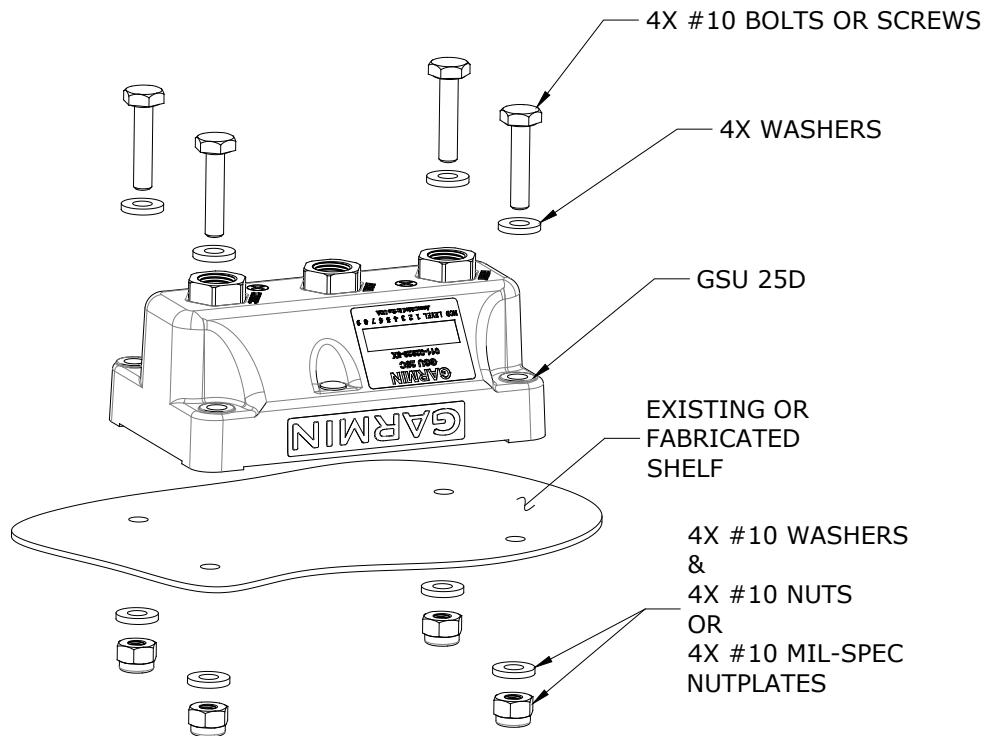

**Figure 6-3 – GDU 460-Mounted GSU 25D (GDU 470 similar)**

**Remote mounted GSU 25D:**

1. Gain access to the GSU 25D. Refer to the location information recorded in APPENDIX A of this document and maintained with the aircraft records.
2. Disconnect the GSU 25D electrical connectors.
3. Disconnect the pitot, static, and AOA lines as required and install plugs or covers to protect the system.
4. Unscrew the four bolts or screws that secure the GSU 25D to the mounting location. Note the mounting orientation for reinstallation.
5. Lift the GSU 25D off the mounting location.





**Figure 6-4 – Remote mounted GSU 25D**

**Reinstallation:**

**GDU-mounted GSU 25D:**

1. Place the GSU 25D on the back of the GDU in the same mounting orientation as it was when removed. Align GSU holes with the mounting holes on the back of the GDU.
2. Insert the four mounting bolts and secure the GSU 25D on the back of the GDU.
3. Connect the pitot, static, and AOA lines.
4. Inspect the electrical connector to ensure there are no bent or damaged pins. Repair any damage.
5. Connect the electrical connectors to the GSU 25D.
6. Reinstall the GDU as noted in Section 6.1.
7. Continue to section 7.2 for configuration and checkout procedures.

**Remote mounted GSU 25D:**

1. Place the GSU 25D on the mounting location in the same mounting orientation as it was when removed. Align GSU holes with the holes on the mounting location. Connect the electrical connectors to the GSU 25D.
2. Insert the four mounting bolts or screws and secure the GSU 25D to the mounting location with washers and nuts (as applicable).
3. Connect the pitot, static, and AOA lines.
4. Inspect the electrical connector to ensure there are no bent or damaged pins. Repair any damage.
5. Connect the electrical connectors to the GSU 25D.
6. Continue to section 7.2 for configuration and checkout procedures.

### 6.3 GMU 11 Magnetometer

Removal:

1. Gain access to the GMU 11. Refer to the location information recorded in APPENDIX A of this document and maintained with the aircraft records.
2. Disconnect the electrical connector.
3. Remove the 4 fasteners that secure the GMU 11 to the mounting location.
4. Lift the GMU 11 off the mounting location.

Reinstallation:

1. Place the GMU 11 in its mounting location and align its holes with the mounting holes.
2. Insert the four mounting screws and secure the GMU 11 in place with washers and nuts. Tighten screws until snug, plus 1/4 turn.
3. Inspect the electrical connector to ensure there are no bent or damaged pins. Repair any damage.
4. Connect the electrical connector to the GMU 11.
5. Continue to section 7.2 for configuration/calibration and checkout procedures.

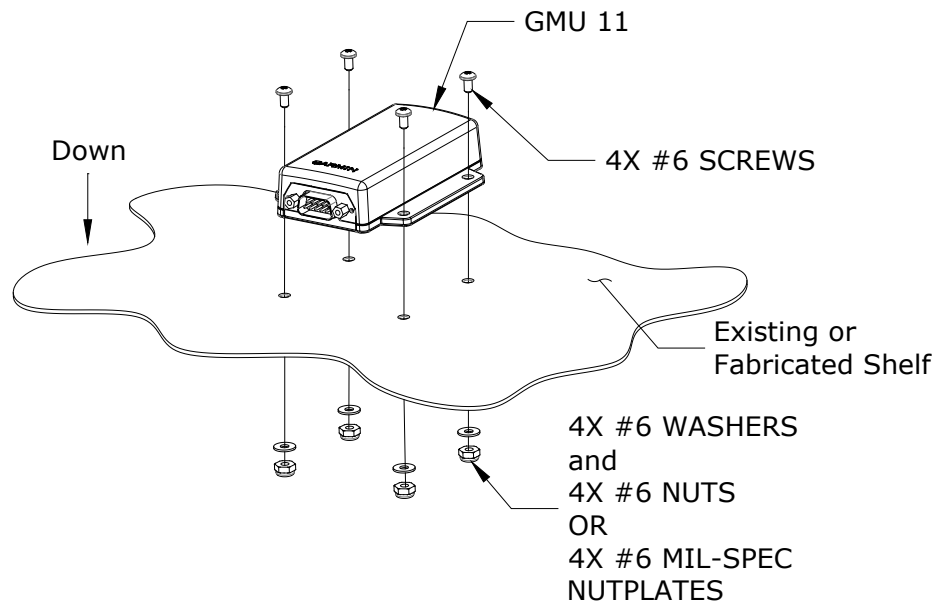

**Figure 6-5 – GMU 11 Magnetometer**

### 6.4 GTP 59 Temperature Probe

Removal:

1. Ensure power is removed from the GSU 25D.
2. Remove the mounting nut and washer from the GTP 59 probe.
3. Pull the GTP 59 from the mounting hole.

Reinstallation:

1. Place the GTP 59 on the previous installation location.
2. Install the washer and nut.
3. Torque nut to 100 +/- 20 in-lbs.
4. Continue to section 7.4 for checkout procedures.



**NOTE**

Reference the G3X Touch EFIS Part 23 AML STC Installation Manual (190-02472-01) for installation of new GTP 59.

1	5		DOUBLER, GTP 59 OAT PROBE
5	4	MS20470AD4-2	RIVET, SOLID, UNIVERSAL HEAD
1	3	494-00022-00	GTP 59 OAT PROBE
1	2	212-00026-00	WASHER, LOCK, SELF-SEALING Ø0.3125 IN
1	1	210-00055-00	NUT, HEXAGONAL, SKIRT 0.3125-32 UNEF-2B
QTY.	ITEM	PART NUMBER	DESCRIPTION

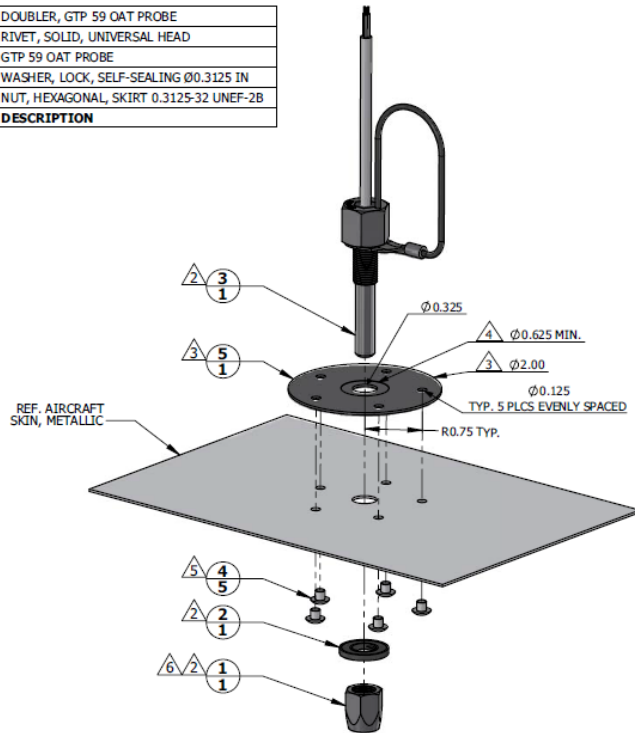

**NOTES**

1. DIMENSIONS ARE IN INCHES UNLESS OTHERWISE SPECIFIED.
2. NUT ITEM 1, WASHER ITEM 2, AND PROBE ITEM 3 ARE PART OF GTP 59 OAT PROBE ASSEMBLY (KIT), GARMIN P/N 011-00978-00.
3. MINIMUM DOUBLER SIZE SHOWN. CIRCULAR SHAPE OPTIONAL. DOUBLER THICKNESS IS ONE GAUGE THICKER THAN AIRCRAFT SKIN.
4. SPOT FACE TO REMOVE COATING AS REQUIRED TO MAINTAIN ELECTRICAL BOND.
5. RIVETS ARE INSTALLED PER MIL-R-47196 (NASM47196) RIVET, BUCK TYPE, *PREPARATION FOR AND INSTALLATION, OR PER MIL-STD-403 PREPARATION FOR AND INSTALLATION OF RIVETS AND SCREWS, ROCKET MISSILE, AND AIRFRAME STRUCTURES.*
6. TORQUE .3125-32 UNEF-2B NUT 100.0±20.0 LBF-IN.

**Figure 6-6 – GTP 59 Temperature Probe**

### 6.5 GAD 27 Electronic Adapter Unit

Removal:

1. Gain access to the GAD 27. Refer to the location information recorded in APPENDIX A of this document and maintained with the aircraft records.
2. Disconnect the GAD 27 connector and ring terminals from the terminal block. Note the location of each ring terminal on the terminal block for proper reinstallation.
3. Remove the four screws and washers and nuts (as applicable) that secure the GAD 27 to the mounting location.
4. Lift the GAD 27 off the mounting location.

Reinstallation:

1. Place the GAD 27 in its mounting location and align its holes with the mounting holes.
2. Insert the four mounting screws and secure the GAD 27 in place with washers and nuts or on

nutplates as applicable.

3. Inspect the electrical connector to ensure there are no bent or damaged pins. Repair any damage.
4. For a newly installed GAD 27, install the d-sub cover plate on unused connector.
5. Connect the connector and ring terminals to the GAD 27.
6. Continue to section 7.5 for configuration and checkout procedures

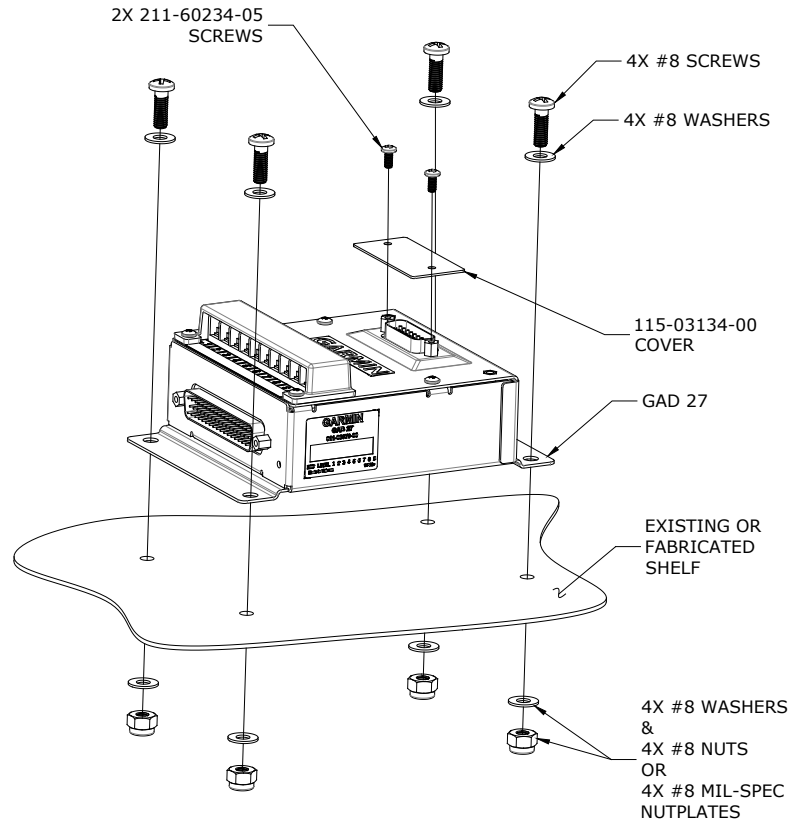

**Figure 6-7 – GAD 27**

### 6.6 GEA 24(B) Engine Indicating System

**Removal:**

1. Gain access to the GEA 24(B). Refer to the location information recorded in APPENDIX A of this document and maintained with the aircraft records.
2. Disconnect the GEA 24(B) electrical connectors.
3. Remove the four screws that hold the GEA to the mounting location.
4. Lift the GEA 24(B) off its mounting location.

**Reinstallation:**

1. Place the GEA 24(B) in its mounting location and align its holes with the mounting holes.
2. Insert the four mounting screws and secure the GEA 24(B) in place.
3. Inspect the electrical connectors and pins for signs of damage. Repair any damage.
4. Connect the wiring harness connectors to the GEA 24(B).
5. Continue to section 7.6 for configuration and checkout procedures.

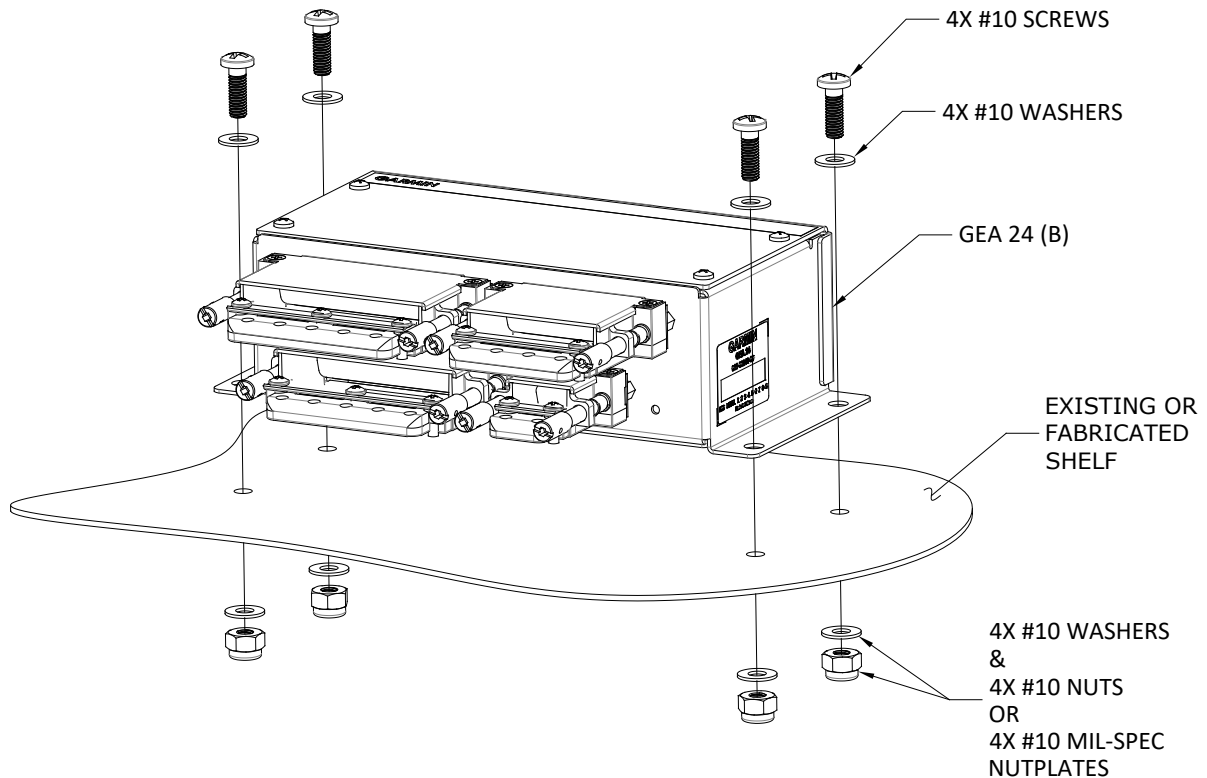

Figure 6-8 – GE A 24(B)

### 6.6.1 EIS Sensors

In addition to the data in this manual and the *G3X Touch EFIS Part 23 AML STC Installation Manual (190-02472-01)*, replacement or re-installation of each probe/sensor and wire must be accomplished in accordance with the sensor manufacturer instructions or as recommended by the engine manufacturer. Wire routing and clamping must follow procedures defined in the aircraft maintenance manual, standard practices manual, or practices defined in *Chapter 11, Electrical Systems, of advisory circular AC 43.13-1B, Aircraft Inspection and Repair*.

Sensors must be connected using hoses and fittings approved as part of aircraft or engine type certificated design or standard aircraft parts (AN/MS) or the *G3X Touch EFIS Part 23 AML STC Installation Manual (190-02472-01)*.

After removing or replacing any EIS sensor, perform the EIS ground checkout procedure for the specific sensor that was affected in Section 8.12

#### 6.6.1.1 Pressure Sensors (Oil, Manifold and Fuel)

Manifold pressure, oil pressure, and fuel pressure sensor installations are similar.

When replacing existing sensors:

- Do not remove engine and fuel fittings with an intentionally reduced orifice. It may limit fluid loss and fire damage in the event of a hose failure.
- Do not remove previously installed devices designed to absorb pressure shock/surge such as a snubber.
- Reuse manifold tubing if it has a vent hole and install the manifold pressure sensor so it is not at the low point in the line.
- Inspect the condition of all existing tubes, hoses, and fittings that are being reused; replace if necessary.

- Verify that the supply voltage and sensor configuration are correct if a different sensor is installed (e.g. if a brass sensor is replaced by a GPT sensor). Refer to Table B-7 for configuration settings.

Install pressure sensors as described in Figure 6-9 or Figure 6-10. When installing pressure sensors:

1. New fuel and oil hoses in the engine compartment must meet TSO-C53a Type C or D (fire resistant). Only use approved aircraft fittings (e.g. AN/AS-spec or Mil-spec) and hoses (e.g. Aeroquip 303 or Aeroquip AE 466). All hoses must be rated for the pressure, temperature, and be compatible with the fuel or oil.
2. Do not install sensors directly below fittings or components that may leak flammable fluid.
3. Thread sealant must be used for the NPT threads. To reduce the risk of system contamination, a minimal amount of sealant should be applied leaving at least two threads at the end of the fitting clear of sealant.
4. Sensor hoses must be routed as far away from the aircraft exhaust system as practical and no closer than 6 inches.
5. Line fittings, routing, alignment, bonding, and support spacing must be installed as defined in the aircraft maintenance manual or section 8-31 of AC 43.13-1B, Aircraft Inspection and Repair.

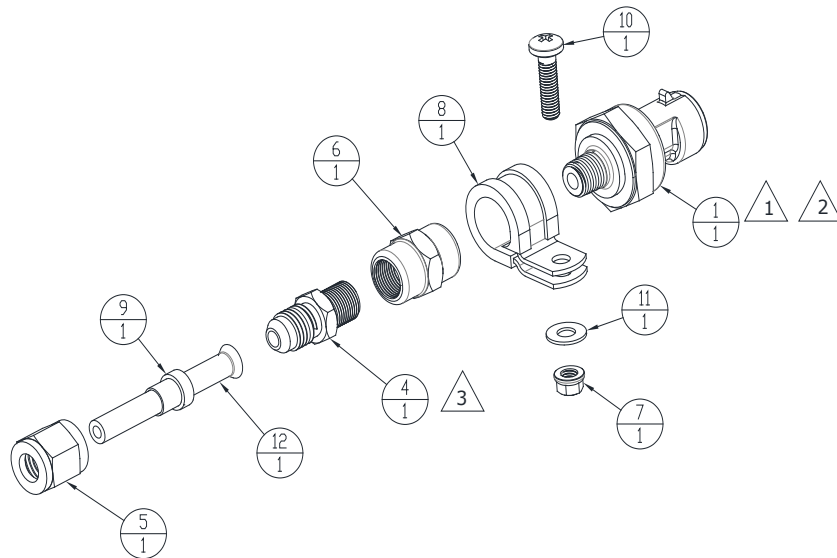

1	12		TUBE, Ø0.190 IN OD
1	11	NAS1149F0332P	WASHER, FLAT, STEEL, CAD PLATED, 0.032 INCH THICK, ID 0.203, OD 0.438
1	10	MS51958-65	SCREW, MACHINE, PAN HEAD, CROSS RECESSED 0.190-32UNF-2A, 3/4 INCH LONG
1	9	MS51533B3	SLEEVE, COMPRESSION, TUBE FITTING, 37° FLARED, Ø3/16 TUBE OD
1	8	MS21919WDG9	CLAMP, LOOP TYPE, CUSHIONED, Ø9/16 TUBE
1	7	MS21042L3	NUT, SELF-LOCKING, REDUCED HEXAGON, REDUCED HEIGHT, RING BASE 0.1900-32UNF-3B
1	6	AN910-1W	COUPLING, PIPE, 1/8-27 ANPT
1	5	AN818-3	NUT, TUBE COUPLING, SHORT, Ø0.1875 TUBE OD 0.3750-24UNJF-3B
1	4	AN816-3	ADAPTER, STRAIGHT, PIPE TO TUBE, 1/8-27 NPT TO 0.3750-24 UNJF-3A
		AN822-3	ADAPTER, ELBOW 90 DEG, PIPE TO TUBE, 1/8-27 NPT TO 0.3750-24 UNJF-3A
		AN823-3	ADAPTER, ELBOW 45 DEG, PIPE TO TUBE, 1/8-27 NPT TO 0.3750-24 UNJF-3A
1	1	011-04202-XX	PRESSURE SENSOR
QTY	ITEM	PART NUMBER	DESCRIPTION

## NOTE

1 TO PREVENT FLUID ENTRAPMENT, ORIENT THE SENSOR SO IT IS NOT STRAIGHT UP.

2 PRESSURE SENSOR HAS 1/8-27 NPT PIPE THREAD. SEE ADDITIONAL LOCATION AND INSTALLATION INFORMATION IN THIS SECTION.

3 EITHER ALUMINUM OR STEEL ADAPTERS ARE ACCEPTABLE. REFER TO APPLICABLE STANDARD FOR MATERIAL OPTIONS.

4 IF HOSE OR TUBING IS PREVIOUSLY INSTALLED, USE APPROVED AIRCRAFT FITTING (E.G. AN/AS-SPECIFICATION OR MIL-SPEC) TO CONNECT THE SENSOR

**Figure 6-9 – Brass Pressure Sensor (Coupling Mount Example)**

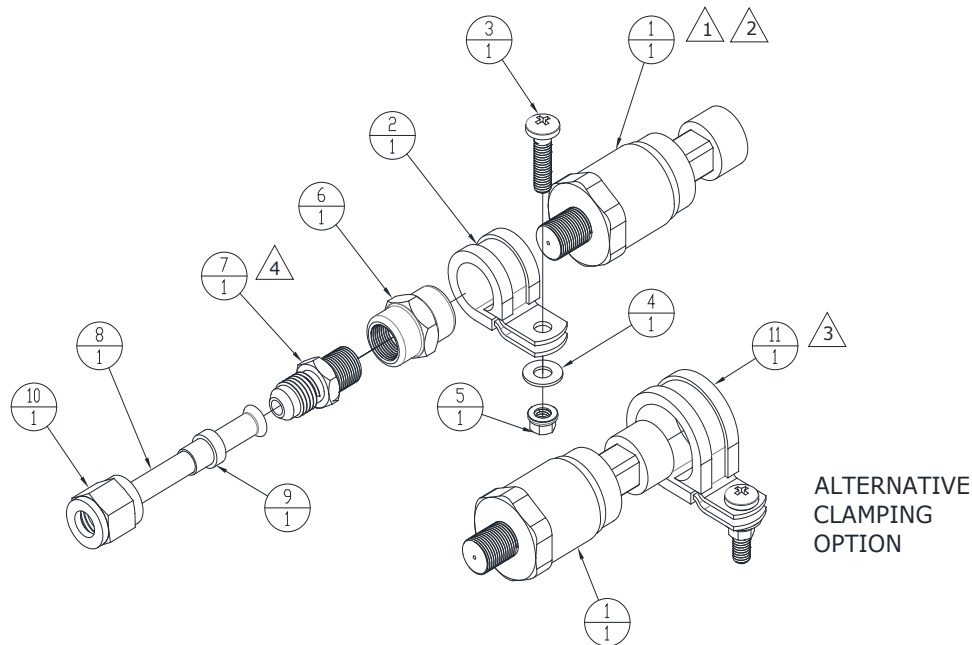

1	11	MS21919WDG14	CLAMP LOOP TYPE, CUSHIONED, SUPPORT, Ø7/8 TUBE
1	10	AN818-3	NUT, TUBE COUPLING, SHORT, Ø0.188 TUBE OD, 0.3750-24 UNJF-3B
1	9	MS51533B3	SLEEVE, COMPRESSION, TUBE FITTING, 37° FLARED, Ø3/16 TUBE OD
1	8		TUBE, Ø0.190 IN OD
1	7	AN816-3	ADAPTER, STRAIGHT, PIPE TO TUBE 1/8-27 NPT TO 0.3750-24 UNJF-3A
		AN822-3	ELBOW. PIPE TO TUBE, 90°, 1/8-27 NPT TO 0.3750-24 UNJF-3A
		AN823-3	ELBOW, PIPE TO TUBE, 45°, 1/8-27 NPT TO 0.3750-24 UNJF-3A
1	6	AN910-1W	COUPLING. PIPE, 1/8-27 ANPT
1	5	MS21042L3	NUT, SELF-LOCKING, 450°F, REDUCED HEXAGON, REDUCED HEIGHT, RING BASE, NON-CORROSION RESISTANT STEEL, 0.190-32 UNF-3B
1	4	NAS1149F0332P	WASHER, FLAT, STEEL, CAD PLATED, 0.032 INCH THICK, ID 0.203, OD 0.438
1	3	MS51958-X	SCREW, MACHINE PAN-HEAD, CROSS-RECESSED, CORROSION RESISTING STEEL, 0.190-32 UNF-2A
1	2	MS21919WDG9	CLAMP LOOP TYPE, CUSHIONED, SUPPORT, Ø9/16 TUBE
1	1	011-05783-XX	PRESSURE SENSOR, GPT
QTY	ITEM	PART NUMBER	DESCRIPTION

**NOTES**

- 1 TO PREVENT FLUID ENTRAPMENT ORIENT THE SENSOR SO IT IS NOT STRAIGHT UP.
  - 2 PRESSURE SENSOR HAS 1/8-27 PIPE THREAD, SEE ADDITIONAL LOCATION AND INSTALLATION INFORMATION IN THIS SECTION.
  - 3 ALTERNATIVE METHOD, CLAMP AROUND THE SENSOR BODY (ITEM 1)
  - 4 EITHER ALUMINUM OR STEEL FITTINGS ARE ACCEPTABLE. REFER TO APPLICABLE STANDARD FOR MATERIAL OPTIONS.
- 5 IF HOSE OR TUBING IS PREVIOUSLY INSTALLED, USE APPROVED AIRCRAFT FITTINGS (E.G. AN/AS-SPECIFICATION OR MIL-SPEC) TO CONNECT THE SENSOR

**Figure 6-10 – GPT Pressure Sensor (Housing & Coupling Mount Examples)**



#### 6.6.1.1.1 Garmin Restrictor Fitting

The Restrictor fitting may be removed for inspection and cleaning in the event of erroneous or lagging manifold pressure indications.

##### Removal and Cleaning

1. Disconnect the tubing or hose from the Restrictor fitting.
2. Remove the Restrictor from the manifold pressure port.
3. Using #80 (0.0135-inch) drill size or welding tip cleaning tool, ensure that no foreign objects are trapped in the orifice. Take care while cleaning to not break off the welding tip inside the orifice.

##### Re-installation

Clean and re-install the Restrictor. Do not exceed two full turns past finger-tight. Re-connect the manifold pressure sensor tubing or hose in accordance with AC 43.13-1B.

#### 6.6.1.2 Oil Temperature

When installing the oil temperature sensor, the unbroken side of the crush washer must face the sensor flange. The sensor is torqued finger tight plus one-half turn and safety wired in accordance with practices defined in Section 7, *Safetying*, of Chapter 7, *Aircraft Hardware, Control Cables and Turnbuckles*, of advisory circular AC 43.13-1B, *Aircraft Inspection and Repair*.

#### 6.6.1.3 Carburetor Air Temperature

The sensor location will vary for different carburetors. Reinstall the carburetor temperature sensor as described in Figure 6-11.



##### **CAUTION**

*Fuel and air passages must remain free of contaminants during work near and around the carburetor.*

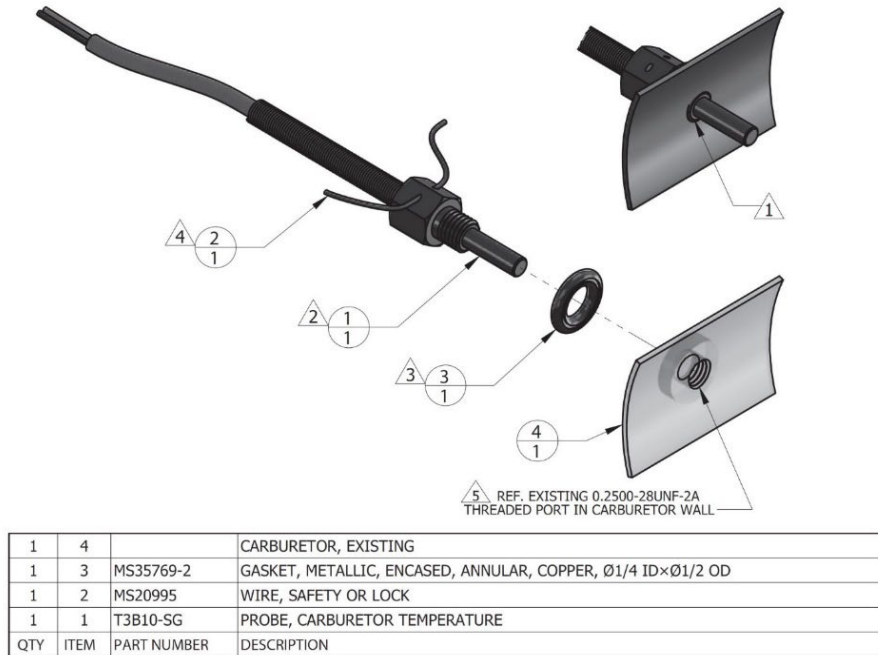

NOTES

- 1 WHEN INSTALLED, FACE OF THE SENSOR THREADED BOSS IS FLUSH WITH THE INSIDE OF CARBURETOR BARREL. USE WASHER(S) IF REQUIRED TO SPACE THE SENSOR ACCORDINGLY.
- 2 T3B10-SG TEMPERATURE SENSOR HAS 0.2500-28UNF-2A THREAD. INSTALL WITH MEDIUM STRENGTH THREADLOCKER. EXERCISE CAUTION TO PREVENT FUEL CONTAMINATION.
- 3 SPLIT FACE OF THE GASKET FACES NON-ROTATING SURFACE.
- 4 SAFETY WIRE PROBE IN ACCORDANCE WITH SECTION 7, SAFETYING OF CHAPTER 7, AIRCRAFT HARDWARE, CONTROL CABLES AND TURNBUCKLES OF AC43-13-1B, AIRCRAFT INSPECTION AND REPAIR.
- 5 SENSOR INSTALLATION IN EXISTING CARBURETOR PORT ONLY. ADDITION OF NEW TAPPED HOLES TO CARBURETOR BARREL NOT ALLOWED.

**Figure 6-11 – Carburetor Air Temperature Sensor Mounting**

**6.6.1.4 Fuel Flow**

The fuel flow transducer may be mounted with a bracket or clamps on the hoses. Reinstall the fuel flow transducer as follows:

- Install the mounting clamps (if used) within six inches of the nearest face of the transducer.
- Install it with the fuel flow direction matching the direction marked on the ports and the wires are not pointing downward.
- Ensure the hose connected to the IN port are straight for a minimum of four inches.
- Ensure the length of hose connected to the OUT port should be level or slope up. It must not slope down more than four inches per foot.

The hoses and fittings connected to fuel flow transducer must meet the following requirements:

- Fuel hoses must not be subject to engine or other movement that could loosen the fittings.
- Replacement hoses must have the same internal diameter as the hose being replaced and meet TSO-C53a Type C or D fire resistant specifications.
- Use fuel compatible thread sealant for the NPT threads. To reduce the risk of fuel system contamination, a minimal amount of sealant should be applied, leaving at least two threads at the end of the fitting clear of sealant. Before connecting any hoses, thoroughly clean and flush the transducer and hoses to insure they are free of any loose material.

- Fitting torque must not exceed 12 ft-lbs., or two full turns past finger tight, whichever occurs first.
- Install the transducer and fuel hoses routed as far away from the aircraft exhaust system as practical. Securely wrap and the transducer with Aeroquip AE102-( ) fire-sleeve if within six inches of any exhaust component.
- Line fittings, routing, alignment, bonding, and support spacing must be installed as defined in the aircraft maintenance manual or section 8-31 of AC 43.13-1B, "Aircraft Inspection and Repair".



**WARNING**

Ensure the fuel flow transducer installation does not introduce thread sealant or debris into the fuel system.



**CAUTION**

Do not blow pressurized air through the flow transducer.

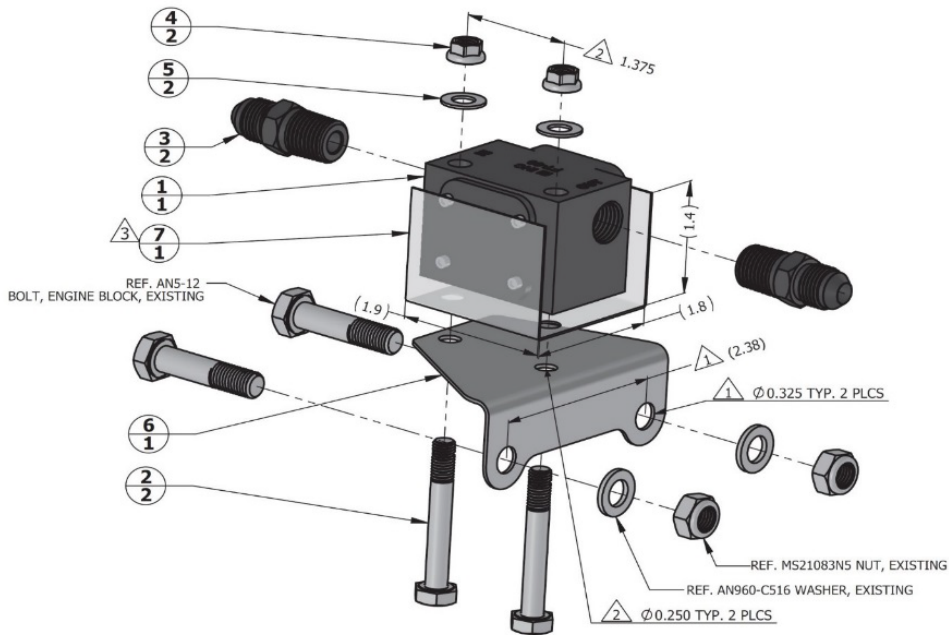

QTY	ITEM	PART NUMBER	DESCRIPTION
1	7		SHIELD, FUEL SENSOR, 5052H2 ALUMINUM, 0.025 IN THICK
1	6		BRACKET, FUEL FLOW SENSOR
2	5	NAS1149F0432P	WASHER, FLAT, STEEL, CAD PLATED, 0.032 INCH THICK, ID 0.265, OD 0.5
2	4	MS21042L4	NUT, SELF-LOCKING, REDUCED HEXAGON, REDUCED HEIGHT, RING BASE .2500-28UNJF-3B
2	3	AN816-5-4	ADAPTER, STRAIGHT, PIPE TO TUBE, 1/4-18 NPT TO .5000-20 UNJF-3A
2	2	AN4-16	BOLT, MACHINE, AIRCRAFT, .2500-28 UNF-3A, 1-5/16 IN GRIP, DRILLED SHANK
1	1	FT-60	FUEL FLOW TRANSDUCER, 68000 PULSES/GAL, ELECTRONICS INTERNATIONAL

**NOTES**

- 1 HOLE SIZE AND SPACING TO MATCH ENGINE CASE BOLTS.
- 2 HOLE SIZE AND SPACING TO MATCH FUEL FLOW TRANSDUCER.
- 3 TRANSDUCER SHIELD IS REQUIRED ONLY IF FUEL FLOW INDICATION FAILS EMI CHECK.

**Figure 6-12 – Fuel Flow Transducer Installation Example**

**6.7 GAD 29B/29D ARINC 429 Adapter**

Removal:

1. Gain access to the GAD 29B/29D. Refer to the location information recorded in APPENDIX A of this document and maintained with the aircraft records.

2. Disconnect the GAD 29B/29D connectors.
3. Remove the four screws that hold the GAD 29B/29D to the mounting location.
4. Lift the GEA 24(B) off its mounting location.

**Reinstallation:**

1. Place the GAD 29B/29D in its mounting location and align its holes with the mounting holes.
2. Insert the four mounting screws and secure the GAD 29B/29D in place.
3. Inspect the electrical connectors and pins for signs of damage. Repair any damage.
4. Connect the wiring harness to the GAD 29B/29D.
5. Continue to section 7.7 for configuration and checkout procedures.

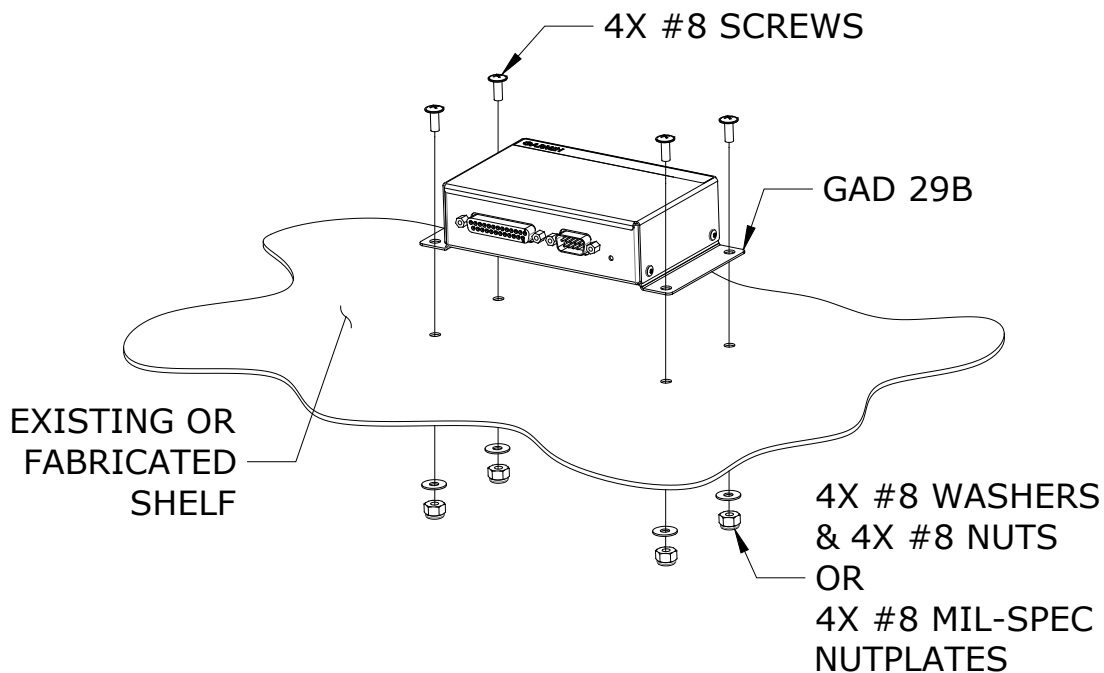

**Figure 6-13 – GAD 29B/29D**

**6.8 GDL 5XR Datalink**

**Removal:**

1. Gain access to the GDL 5XR. Refer to the location information recorded in APPENDIX A of this document and maintained with the aircraft records.
2. Disconnect the GDL 5XR electrical and coax cable connectors as applicable.
3. Remove the four screws that secure the GDL 5XR to the mounting location.
4. Lift the GDL 5XR off the mounting location.

**Reinstallation:**

1. Place the GDL 5XR in its mounting location and align its holes with the mounting holes.
2. Insert the four mounting screws and secure the GDL 5XR in place with washers and nuts (as appropriate).
3. Inspect the electrical connector to ensure there are no bent or damaged pins. Repair any damage.
4. Connect the electrical and coax connectors as applicable to the GDL 5XR.

5. Continue to Section 7.8 for configuration and checkout procedures.

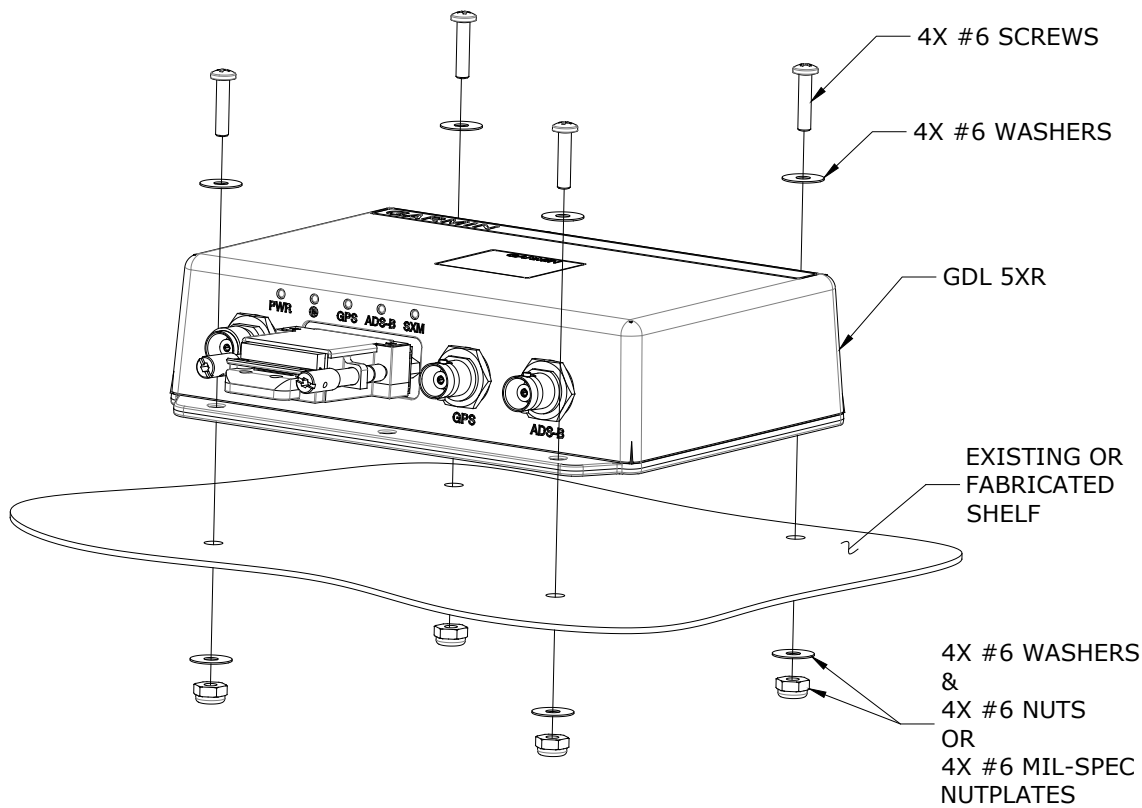

**Figure 6-14 – GDL 5XR (GDL 52R Shown)**

**6.9 GPS Antenna (P/N 011-04036-00 or 011-04036-10)**

Removal:

1. Remove power from the aircraft.
2. Disconnect the GPS antenna coax cable from the back of the PFD.
3. Remove the screws (if applicable) or pull on antenna to separate the fastener tape (hook & loop material) securing the antenna on the glareshield.
4. Lift up on the GPS antenna from the glareshield to remove it.

Reinstallation:

1. Place the antenna on the mounting location on the glareshield.
2. Secure the antenna as applicable with screws or hook & loop material.
3. Connect the GPS antenna coax cable to the back of the PFD.
4. Coil any excess coax cable and secure with cable ties.
5. Conduct return to service procedures in Section 8 as applicable.

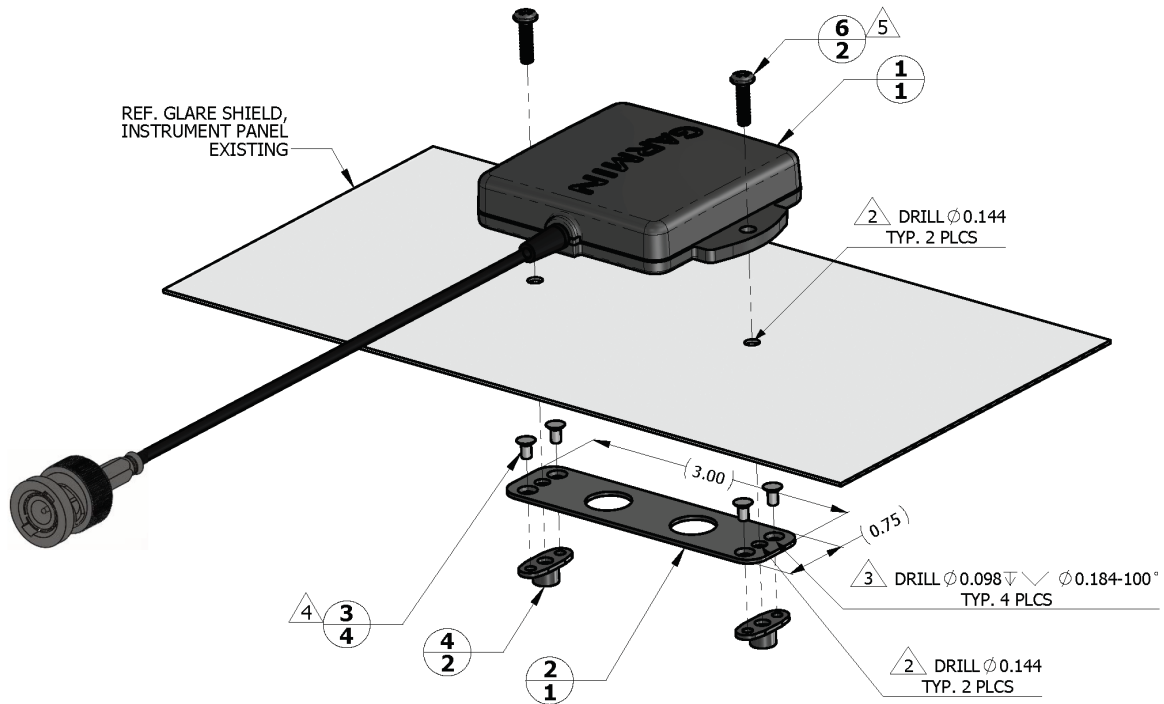

2	6	MS35206-229	SCREW, MACHINE, PAN HEAD, CROSS RECESSED, CAD PLATED .1380- 32 UNC-2A, 0.438 IN LONG
		MS35214-26	SCREW, MACHINE, PAN-HEAD, CROSS RECESSED, BLACK OXIDE FINISH .1380- 32 UNC-2A, 0.438 IN LONG
2	4	MS21069L06	NUT, SELF-LOCKING, PLATE, TWO-LUG, REDUCED RIVET SPACING, LOW HEIGHT, STEEL .138-32 UNJC-3B
4	3	MS20426AD3-3	RIVET, SOLID, COUNTERSUNK 100 DEG, PRECISION HEAD, 3/32 IN OD, 3/16 IN LONG
1	2	PLATE DETAIL	SHEET, 6061-T6 AL, 0.040 INCH THICK PER AMS 4025, AMS 4027, AMS-QQ-A-250/11
1	1	011-04036-10	BACKUP GPS ANTENNA
<b>QTY</b>	<b>ITEM</b>	<b>PART NUMBER</b>	<b>DESCRIPTION</b>

**NOTES**

1. DIMENSIONS ARE IN INCHES UNLESS OTHERWISE SPECIFIED.
2. FASTENER HOLES ARE LOCATED TO MATCH BACKUP GPS ANTENNA ITEM 1.
3. FASTENER HOLES ARE LOCATED TO MATCH NUTPLATE ITEM 4.
4. RIVETS ARE INSTALLED PER MIL-R-47196 (NASM47196) RIVET, BUCK TYPE, *PREPARATION FOR AND INSTALLATION*, OR PER MIL-STD-403 *PREPARATION FOR AND INSTALLATION OF RIVETS AND SCREWS, ROCKET MISSILE, AND AIRFRAME STRUCTURES*.
5. USE FASTENER WITH BLACK OXIDE FINISH IF ANTENNA LOCATION IS SUCH THAT FASTENERS ARE VISIBLE TO THE PILOT OR COPILOT AND MIGHT BECOME A SOURCE OF ACCIDENTAL GLARE. TORQUE .1380-32 UNC-2A SCREWS HAND TIGHT.

**Figure 6-15 – GPS Antenna (Screw-mounted Installation Example)**

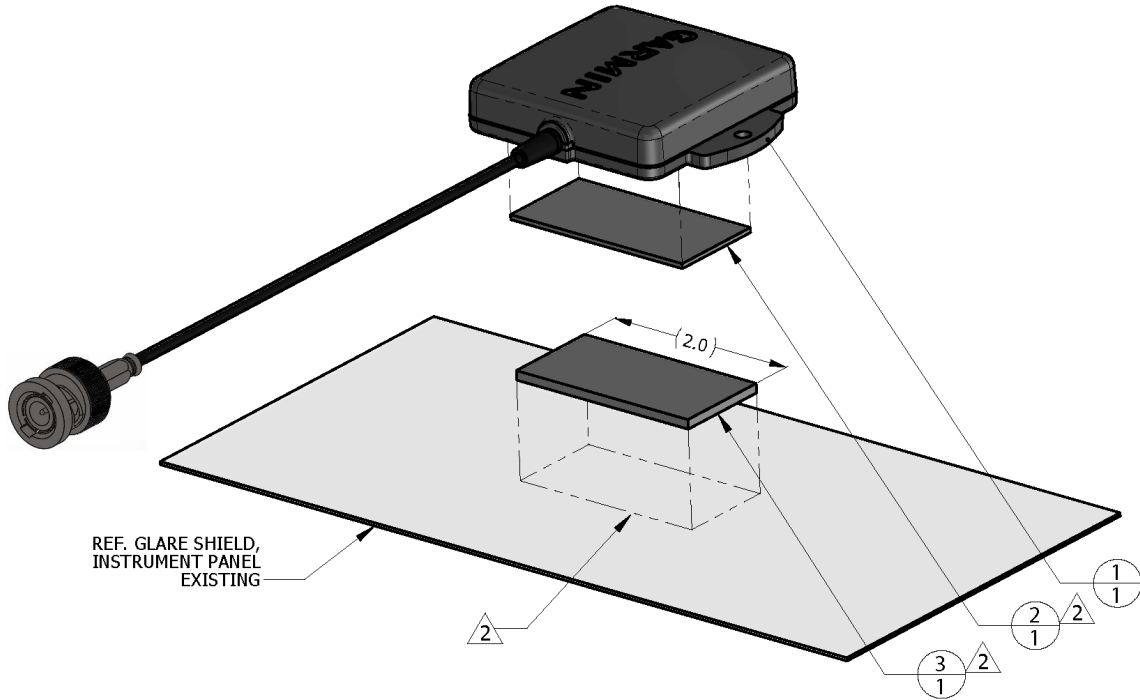

QTY	ITEM	PART NUMBER	DESCRIPTION
1	3	A-A-55126 <sup>△</sup> 3	FASTENER TAPE, SYNTHETIC, ADHESIVE BACKED, A-A-55126 CLASS 1/2, TYPE 1, LOOP 1.0 INCH WIDE
	2		FASTENER TAPE, SYNTHETIC, ADHESIVE BACKED, A-A-55126 CLASS 1/2, TYPE 1, HOOK 1.0 INCH WIDE
1	1	011-04036-10	BACKUP GPS ANTENNA

**NOTES**

1. DIMENSIONS ARE IN INCHES UNLESS OTHERWISE SPECIFIED.
- <sup>△</sup>2 PEEL OFF ADHESIVE PROTECTING FILM AND PRESS THE FASTENER TAPE IN TO BOND. SURFACES MUST BE CLEAN AND FREE FROM OIL OR OTHER CONTAMINANTS. LOOP FASTENER IS BONDED TO GLARE SHIELD AND HOOK FASTENER IS BONDED TO ANTENNA. TAPE FASTENER MUST BE 2.0 INCHES OR LONGER.
- <sup>△</sup>3 GPS ANTENNA KIT, GARMIN PART NO. 010-12444-00 INCLUDES DUAL LOCK FASTENER, GARMIN PART NO. 252-00433-00 WHICH CAN BE USED INSTEAD OF A-A-55126 FASTENER TAPE.

**Figure 6-16 – GPS Antenna (Hook and Loop Installation Example)**

**6.10 GTR 20 Remote-Mount VHF COM**

Removal:

1. Gain access to the GTR 20. Refer to the location information recorded in APPENDIX A of this document and maintained with the aircraft records.
2. Disconnect the GTR 20 electrical and coax connectors.
3. Remove the four screws, washers and nuts (as applicable) that secure the GTR 20 to the mounting location.
4. Remove the GTR 20 unit.

Reinstallation:

1. Place the GTR 20 in its mounting location and align its holes with the mounting holes.
2. Insert the four mounting screws and secure the GTR 20 in place with washers and nuts or nutplates as applicable.
3. Inspect the electrical connector to ensure there are no bent or damaged pins. Repair any damage.
4. Connect the electrical and coax connectors to the GTR 20.
5. Continue to section 8 for configuration and checkout procedures

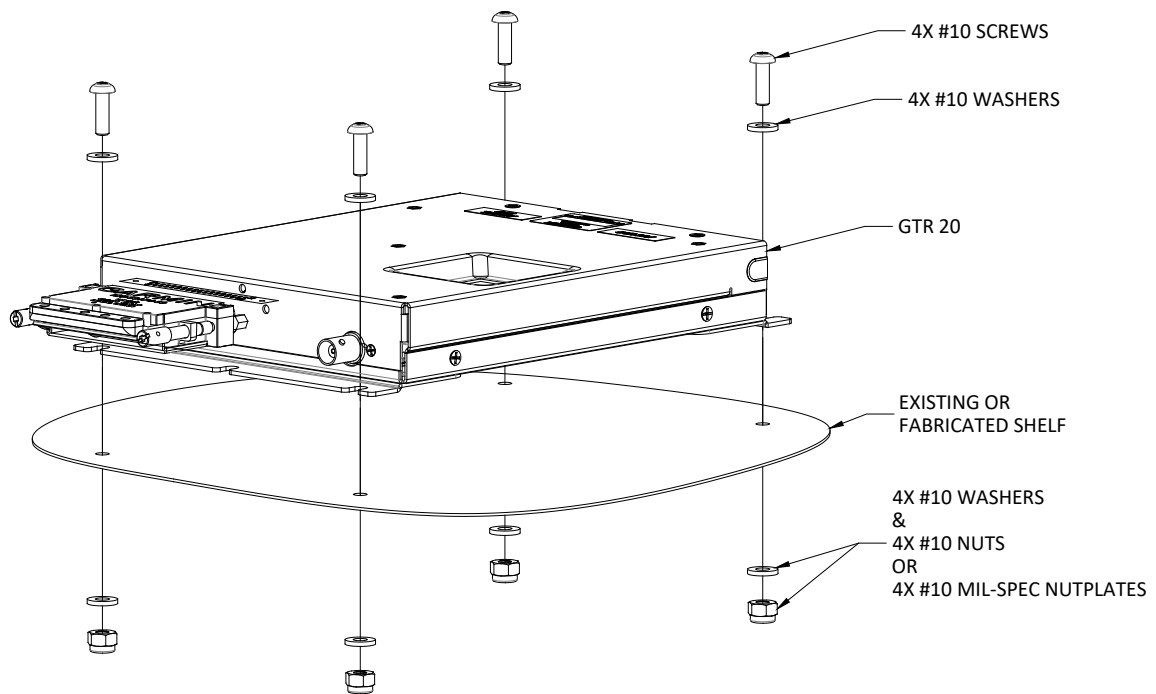

**Figure 6-17 – GTR 20 VHF COM Radio**

**6.11 GTR 200B VHF COM Radio**

Removal:

1. GTR 200B is installed on the instrument panel in a rack.
2. Insert a 3/32" hex drive tool into the access hole on the lower right corner of the face of the unit.
3. Turn the tool counterclockwise until it stops.
4. Pull the unit from the rack.

Reinstallation:

1. Slide unit into the rack or panel cutout until it stops.
2. Insert a 3/32" hex drive tool into the access hole on the lower right corner of the face of the unit.
3. Push on the GTR 200B bezel while turning the tool clockwise until the unit is securely seated in the rack. Do not exceed 15 in-lbs. of torque.
4. Continue to Section 8.14 for configuration and checkout procedures.

**6.12 GMA 245R w/Marker Beacon Audio Panel**

Removal:

1. Gain access to the GMA 245R. Refer to the location information recorded in APPENDIX A of this document and maintained with the aircraft records.
2. Disconnect the GMA 245R connectors.
3. Remove the six screws, washers and nuts (as applicable) that secure the GMA 245R to the mounting location.



4. Remove the GMA 245R unit.

**Reinstallation:**

1. Place the GMA 245R in its mounting location and align its holes with the mounting holes.
2. Insert the six mounting screws and secure the GMA 245R in place with washers and nuts or nutplates as applicable.
3. Inspect the electrical connectors to ensure there are no bent or damaged pins. Repair any damage.
4. Connect the electrical connectors to the GMA 245R.
5. Continue to section 8.5 for configuration and checkout procedures

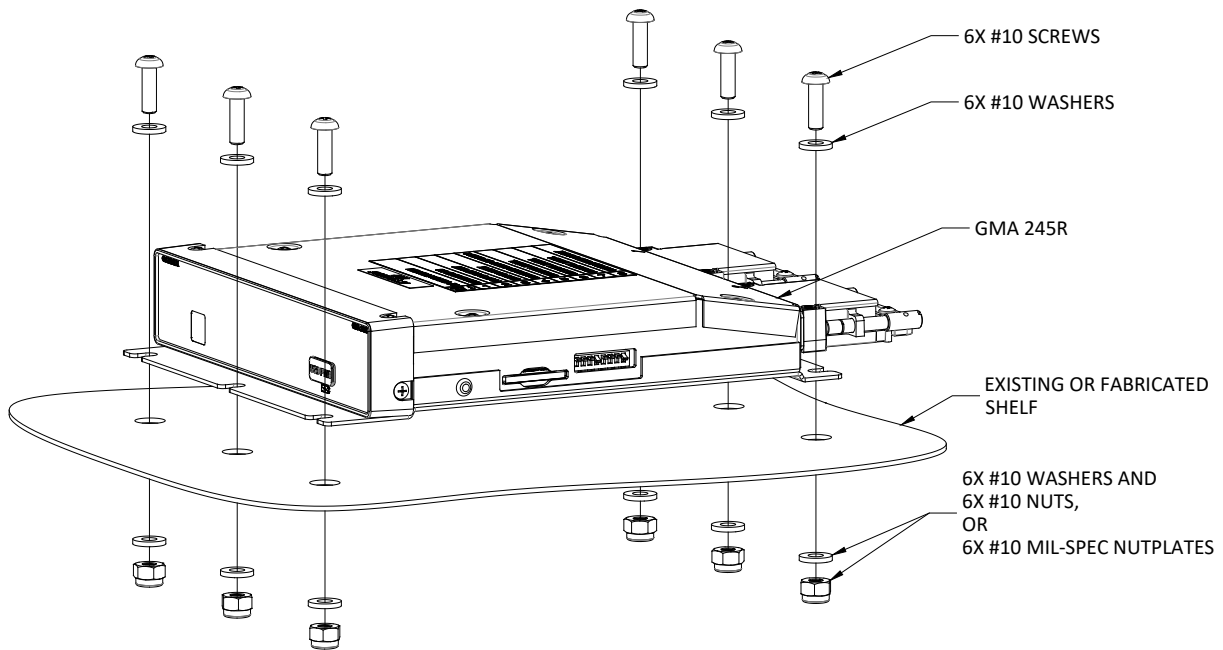
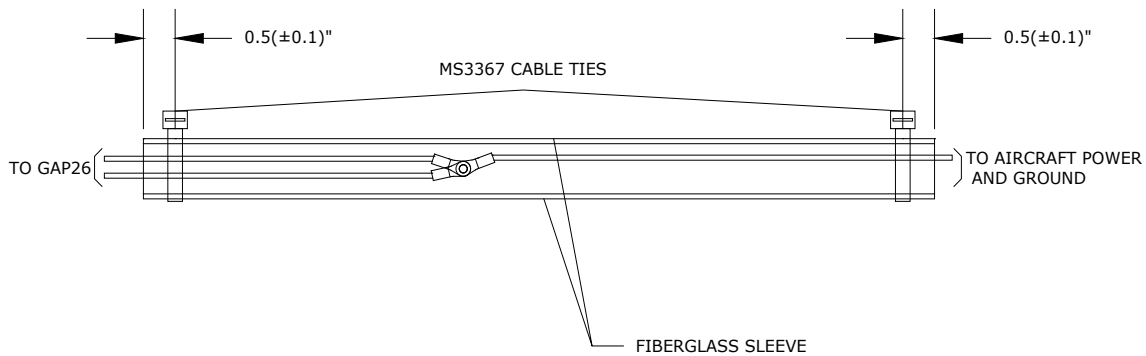

**Figure 6-18 – GMA 245R Audio Panel**

**6.13 GAP 26 AOA Probe**

**Removal:**

1. Locate the GAP 26 AOA probe on the underside of either wing. Place an aligning mark on the inspection panel and wing to allow correct reinstallation.
2. While supporting the AOA probe, remove the screws from the inspection panel attached to the probe.
3. Carefully lower the probe from the wing and while supporting the AOA probe, disconnect AOA tube from tube inside wing and the electrical wires from the mechanical splice. Shown below is splice if 10 AWG wire is used on 14-volt aircraft.



**Figure 6-19 – GAP 26 Mechanical Splice Detail (14-volt Aircraft with 10 AWG Wire)**

4. With the probe disconnected from the aircraft, place an aligning mark on the probe and mount bracket to ensure it is reinstalled in the correct orientation.
5. Remove the four screws from the mount tube to separate from the probe.



**NOTE**

*AOA and pitot tubes are flexible and may require straightening to allow to slide out of the mount tube.*

6. Pull the probe from the mount tube.

**Reinstallation:**

1. Insert probe on the mount tube and align its holes with holes on the mount tube. Ensure the mark on the probe aligns with mark on mounting tube.
2. Insert the four mounting screws and secure the GAP 26 probe on mount tube.
3. While supporting the inspection panel with probe assembly, connect the mechanical splice and AOA tube to tube inside the wing.



**NOTE**

*Ensure pitot tube is capped, reference G3X Touch EFIS Part 23 AML STC Installation Manual (190-02472-01) for details.*

4. Ensuring proper orientation of the inspection panel and AOA probe assembly on the wing, insert the screws on the inspection panel holes and secure to aircraft structure.
5. Continue to section 8.18 for configuration and checkout procedures

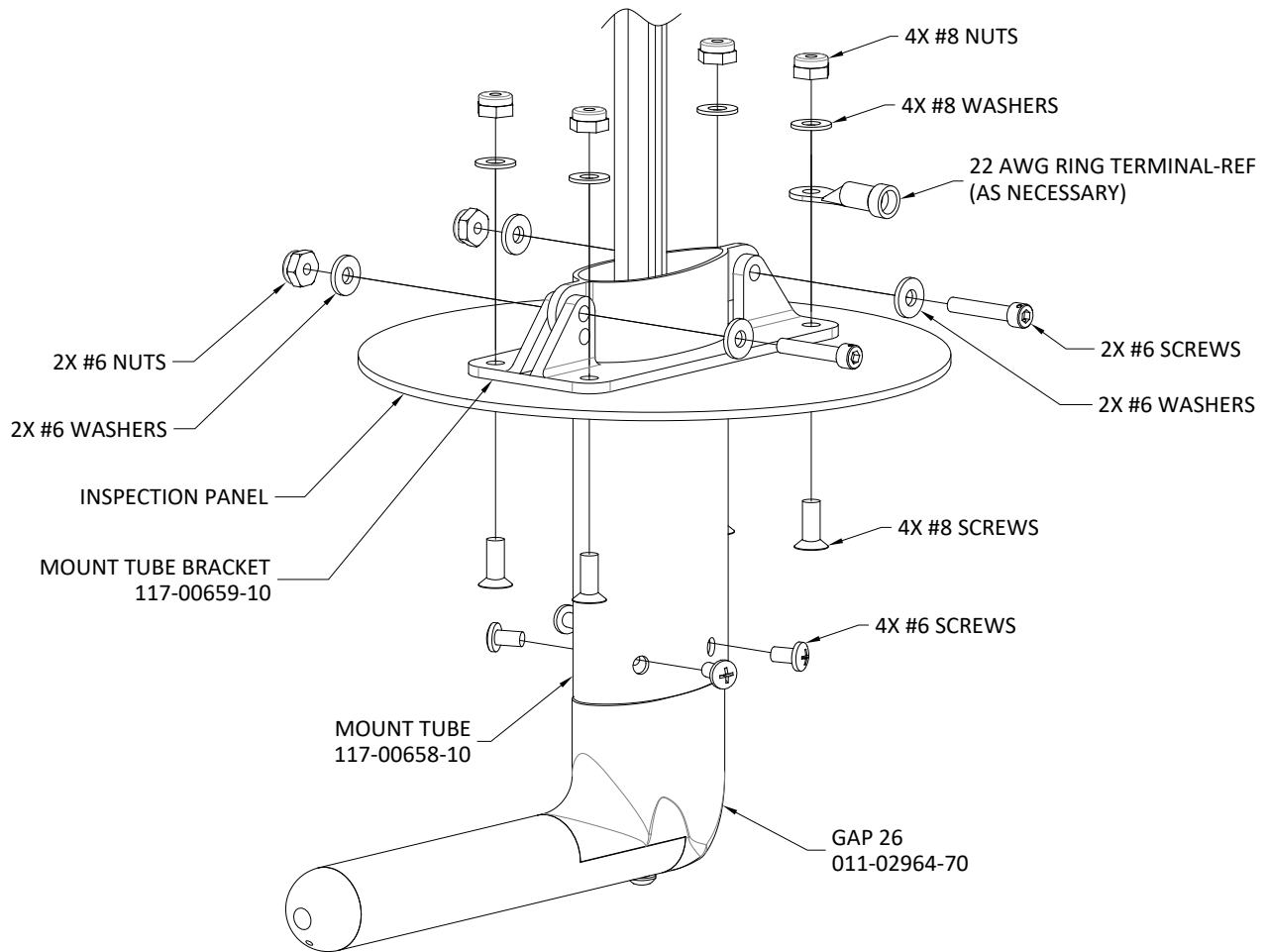

Figure 6-20 – GAP 26 AOA Probe Assembly

### 6.14 EIS Annunciator Lights

There are two indicator lights one with a red lens and one with amber lens and must not be interchanged. Remove and replace/reinstall one light at time to prevent swapping them



**CAUTION**

To avoid erroneous indication of the EIS gauges, the position of each color-coded lens must be noted and reinstalled in its original position. Reference the G3X Touch Part 23 AML STC Installation Manual (190-02472-01) for the correct location of each indicator.

Removal

1. Locate the EIS annunciator lights on the instrument panel. Ensure the forward side of the instrument panel is accessible.
2. Loosen and remove the lens holder from the assembly and note the position of each on the instrument panel.
3. While holding the jam nut on the forward side of the instrument panel, loosen and remove the jam nut and washer on the aft side of the instrument panel (lens side).
4. Pull the indicator forward away from the instrument panel.

Reinstallation:

1. Insert the indicator from the forward side of the instrument panel.
2. While supporting the jam nut and pushing the indicator against the panel, insert the washers and nut on the indicator.
3. Fasten the nut on the aft side of the panel against the lock washer.
4. Install and secure the lens holder on the indicator.

#### **6.14.1 EIS Annunciator Lamp Replacement.**

1. Loosen the remove the lens holder.
2. Pull the lamp from base flange on the opposite end of the lens.
3. Install new lightbulb 28 VDC P/N MS25237-327 (GE or JKL lamp number 327) or 14 VDC P/N MS25237-330 (GE or JKL lamp number 330 in the lens holder.
4. Install and secure lens holder on the indicator.

## 7. G3X EQUIPMENT CONFIGURATION & TESTING

This section provides procedures to be performed after a G3X unit is removed and reinstalled or replaced. At the beginning of each LRU section, instructions are given to guide the technician for various removal/replacement scenarios. These instructions define necessary procedures to be followed for situations where original equipment was reinstalled as well as for situations where new equipment (new serial number) is installed.

### 7.1 GDU 4X0

#### Original GDU 4X0 is Reinstalled

No software or configuration loading is required if an original GDU 4X0 is reinstalled. This does not include units that were returned for repair as their software and configuration files are deleted during the repair testing process. Continue to Section 7.1.3.

#### New, Repaired, or Exchanged GDU 4X0 is Installed

If a new, repaired, or exchange GDU 4X0 is installed, the correct software must be loaded to the unit. Continue to Section 7.1.2.

#### 7.1.1 New PFD Configuration Module Installed

If a new configuration module is installed and no change is made to the PFD, the required configuration information will be written to the new module by the PFD. If both the PFD and configuration module are replaced with new modules, configuration of the system is required. Reference Section 5 of *G3X Touch EFIS Part 23 AML STC Installation Manual* (190-02472-00) for configuration information.



#### NOTE

*Do not use a used GDU configuration module as a replacement. Data that may reside on a used configuration module may cause system configuration errors.*

#### 7.1.2 GDU Software Loading

Continue to section 7.13 for GDU software loading procedures.

#### 7.1.3 GDU Display Testing

1. Apply power to the aircraft and allow the displays to initialize for approximately one minute. Verify proper display of data and no red-x's.
2. If no other service is to be performed, continue to the return-to-service procedures in Section 8.

### 7.2 GSU 25D ADAHRS and GMU 11 Magnetometer

#### Original GSU 25D is Reinstalled

No software or configuration loading is required if the removed GSU 25D is reinstalled.

#### New, Repaired or Exchange GSU 25D is Installed

If a new, repaired or exchange GSU 25D is installed, the correct software will be loaded automatically by the G3X GDU when power is applied to the system.

#### Original GMU 11 is Reinstalled

No software or configuration loading is required if the removed GMU 11 is reinstalled. Continue to Section 7.2.1.

New, Repaired, or Exchange GMU 11 is Installed

If a new, repaired, or exchange GMU 11 is installed, the correct software will be loaded automatically by the G3X GDU when power is applied to the system. Continue to Section 7.2.1.

**7.2.1 GSU 25D/GMU 11 Testing and Calibration**

Table 7-1 describes the calibration procedures to be performed for GSU 25D and/or GMU 11 units after maintenance is performed.

For new GSU 25D and/or GMU 11, or if the mounting bracket/shelf and/or pitot/static/AOA lines have been disturbed, perform the following tests/procedures.

1. Perform a pitot-static leak check in accordance with the aircraft manufacturer's specification and/or applicable regulations.



**CAUTION**

*To avoid damaging the ADAHRS pressure sensors, the pitot and static and GAP 26 (if installed) must all be connected to the test set. Note that the GAP 26 has drain holes on the underside of the probe which must be covered during the test.*



**NOTE**

*If excessive leakage is detected while the test set is connected to the GAP 26, verify that there are no leaks where the test set connects to the AOA port or drain hole. If the test set connection also includes the GAP 26 pitot opening, verify that it covers the pitot drain hole as well. Verify that the unused pitot line coming out of the GAP 26 is securely capped in accordance with the G3X Touch EFIS Part 23 AML STC Installation Manual (190-02472-01). If leakage is still suspected from the GAP 26, disconnect the probe from the AOA line and connect the test set directly to the AOA line (or directly to the AOA port on the GSU 25D).*

2. Pitch/Roll Offset Compensation by Aircraft Leveling (Section 7.2.1.1)
3. Magnetometer Calibration (Section 7.2.1.2).
4. Magnetometer interference test (Section 5.4.4)
  - The addition, removal, or modification of components that are ferrous (magnetic), or electrical changes to the installation that affect components within 10 feet of the GMU 11 magnetometer location after the Magnetometer Interference Test (Section 8.13.1) or Magnetometer Calibration (Section 7.2.1.2) were completed, requires a repeat of the Magnetometer interference test procedures. If new magnetic interference is detected, it must be resolved, then the Magnetometer Calibration (Section 7.2.1.2) must be repeated.
5. Altimeter Check (Section 8.13.1).
  - If the altimeter check (Section 8.13.1) fails, ADAHRS Static Pressure Calibration (Section 7.2.1.3) must be performed.
6. Engine run-up vibration test (Section 7.2.1.4).
7. Compass swing (Section 8.13.3). *Must be performed after magnetometer calibration to verify the ADAHRS/GMU 11 heading accuracy.*



**NOTE**

*For a new GSU 25D or GMU 11 and if the mounting screws that secure the mounting rack is loosened for any reason affecting the orientation of the unit, ADAHRS Unit Orientation and Magnetometer Orientation respectively, must be repeated in accordance with the G3X Touch EFIS Part 23 AML STC Installation Manual (190-02472-01).*

**Table 7-1 – GSU 25D/GMU 11 Recalibration Criteria**

Condition	Calibrations Required		
	GSU Pitch/Roll Offset Calibration	GSU 25D/GMU 11 Magnetometer Calibration	Engine Run-up Vibration Test
GMU 11 was removed and reinstalled. (no change in serial number)	None Required. Continue to GSU 25D/GMU 11 Checkout Procedures		
GMU 11 was replaced with new unit. (New serial number)		X	
GSU 25D was removed and reinstalled. The mounting bracket was NOT removed, and the mounting bracket bolts were NOT loosened. (same serial number)	None Required. Continue to GSU 25D/GMU 11 Checkout Procedures		
GSU 25D was removed and reinstalled. The mounting bracket WAS removed and/or mounting bracket bolts WERE loosened.	X	X	X
GSU 25D was replaced with new unit. (New serial number)	X	X	X

**7.2.1.1 Pitch/Roll Offset Compensation by Aircraft Leveling**



**NOTE**

*Prior to performing the following procedure, the aircraft must be leveled using the procedures in the aircraft maintenance manual.*

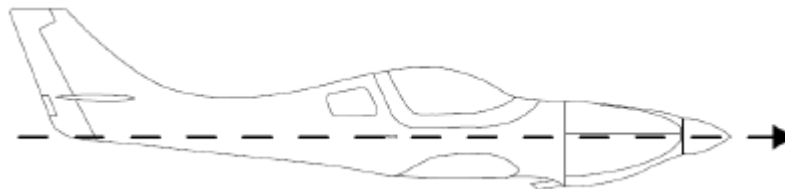

**Figure 7-1 – Aircraft Level Attitude**

Use the following procedure to set GSU 25D pitch and roll compensation on the aircraft;

1. Select the ADAHRS Calibration Page.
2. Ensure that all the required status boxes are checked.
3. Select Pitch/Roll Offset.
4. Ensure that aircraft and ADAHRS comply with all on-screen instructions, then select the START button.

5. "Pitch/roll offset calibration in progress" will appear on the display along with calibration information.

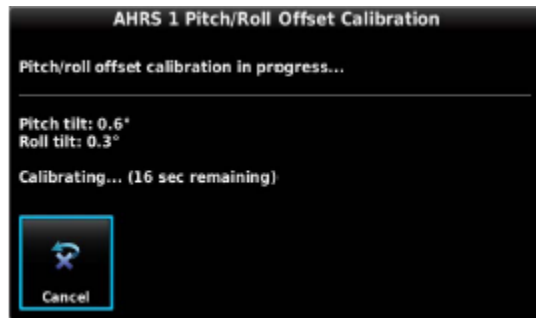

Figure 7-2 – Pitch/Roll Offset Calibration in Progress



**NOTE**

*The GSU 25D pitch/roll offset procedure has a 30 second countdown timer that resets if the aircraft moves.*

6. When the calibration has completed "Success" or "Failure" will be displayed; select the DONE softkey to return to the ADAHRS Calibration screen.

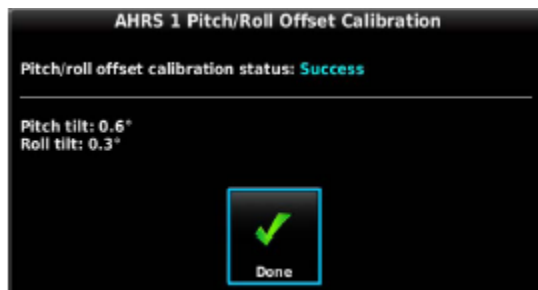

Figure 7-3 – Pitch/Roll Offset Completion Status



**NOTE**

*Magnetometer Calibration must be completed after each ADAHRS pitch/roll offset calibration.*



**NOTE**

*The subsequent ADAHRS and magnetometer procedures are carried out with the aircraft engine running. Start and operate the aircraft engines in accordance with Pilot's Operating Handbook (POH) or Aircraft Flight Manual (AFM).*

**7.2.1.2 Magnetometer Calibration**



**NOTE**

*The Pitch/Roll Offset Compensation procedure in section 7.2.1.1 must be completed prior to performing this procedure.*



Use a compass rose or calibrated magnetic sight compass to calibrate the magnetometer. Ensure that the aircraft and compass are located away from magnetic interference sources including buildings. The accuracy of the ADAHRS cannot be guaranteed if the calibration is not performed in an area that is free of metallic structure or objects.

With the aircraft stationary, initiate the magnetometer calibration procedure as follows:

1. Start the aircraft engine per the POH/AFM.
2. Taxi the aircraft to a desired calibration area.



**NOTE**

*Ensure that there are no nearby magnetic materials on or near the perimeter of the site. If unavoidable, maneuver the aircraft to keep the magnetometer from passing within 20 feet of such objects. Ensure that vehicles or other aircraft are a minimum of 40 feet away from the aircraft during this procedure.*

3. At the site, align the aircraft to a heading of magnetic north (+/- 5°). It is best to offset the aircraft position to the left (west) of the North/South axis to allow turning clockwise around the site as indicated below.

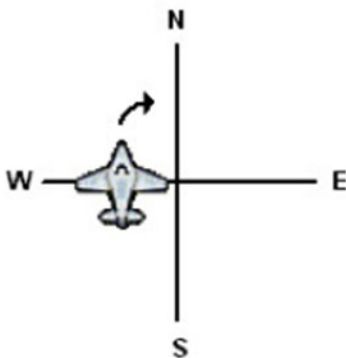

**Figure 7-4 – Compass Rose Starting Position**

4. Power on the display(s) in Configuration Mode.
5. Select the Magnetometer Calibration Page.
6. Select Magnetometer Calibration.
7. Ensure that all on-screen instructions have been complied with and select the Start button to begin the calibration.



Figure 7-5 – Magnetometer Calibration On-Screen Instructions

8. Follow the on-screen instructions, the dots at the end of the text will be removed as the test progresses.

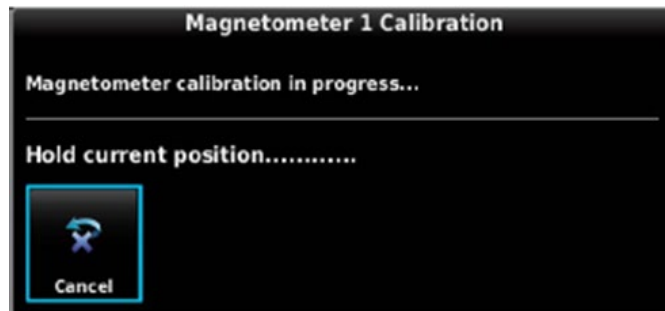

Figure 7-6 – Magnetometer Calibration Progress

9. Follow the on-screen instructions by slowly turning the aircraft to the right, the dots at the end of the text will be removed as the aircraft rotates 30 degrees. When all dots have been removed, and the text changes to 'Hold Position', stop turning the aircraft, and wait for further instructions.
10. Continue following the on-screen instructions until the calibration is completed. The calibration will go through twelve cycles of holding, then turning to the right, before completing a full circle.
11. When the calibration is finished, ensure that a Calibration Status of "Success" is displayed, then press the Done softkey to return to the Magnetometer Configuration Page.



**NOTE**

*If smooth accurate turns are not made, the ADAHRS may incorrectly interpret a station and instruct to "Hold current position..." prior to or after completion of the heading change. If this scenario is encountered, it is best for the operator to temporarily ignore the "Hold current position..." command and instead use compass rose references to complete the heading change. Dwelling at these 30° increments for the time recommended by the ADAHRS should result in successful calibration.*

**7.2.1.3 ADAHRS Static Pressure Calibration**

The ADAHRS Calibration page, in configuration mode, has a selection for ADAHRS Static Pressure Calibration. This procedure is used to perform an altimeter re-calibration.



**NOTE**

*This calibration is only used when an ADAHRS fails a periodic altimeter test and should only rarely, if ever, be used. Prior to using this procedure, all possible sources of leakage in pneumatic lines, fittings, and GAP 26 should be ruled out (if necessary, connect the test set directly to the pitot/static/AOA ports on the GSU 25D to verify).*

The static pressure calibration requires the use of a pressure control system (test set) with an altitude accuracy of at least +/- 5 ft at sea level and +/- 20 ft at 30,000 ft. It is necessary to re-calibrate to sea level (0 ft), 10,000 ft, 20,000 ft, and optionally to 30,000 ft. Calibration to 30,000 ft is only required for aircraft that may reach that displayed altitude.



**CAUTION**

*To avoid damaging the ADAHRS pressure sensors, the pitot and static ports and GAP 26 (if installed) must be connected to the test set. Note that the GAP 26 has drain holes on the underside of the probe which must be covered during the test.*

1. Connect the pressure test set to the pneumatic ports on the aircraft skin.
2. Power on the PFD in configuration mode if it is not already in configuration mode.
3. Select the ADAHRS Calibration Page.
4. Select Static Pressure Calibration.

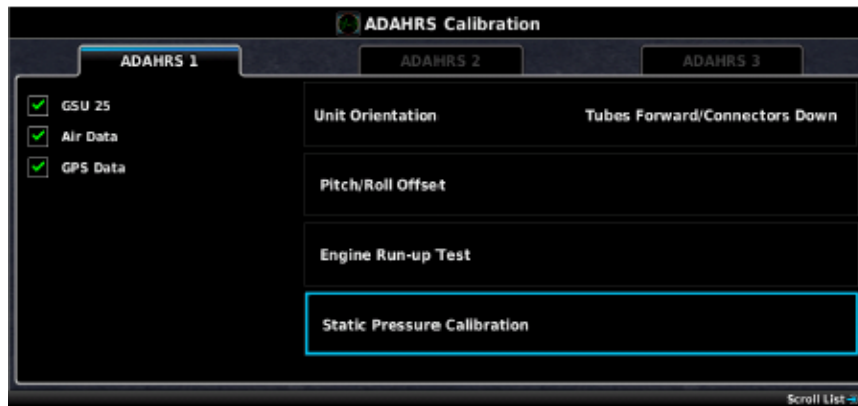

**Figure 7-7 – Static Pressure Calibration**

5. Select “OK” to continue the calibration.

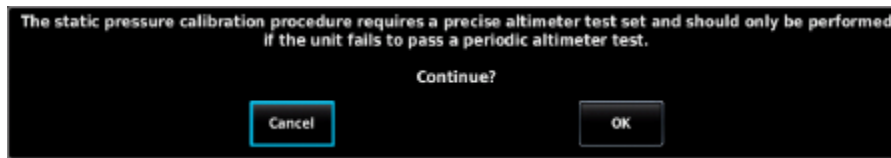

**Figure 7-8 – Static Pressure Calibration Warning**

6. Ensure that all on-screen instructions have been complied with and all information displayed is correct, then select the “Start” button to begin the calibration.

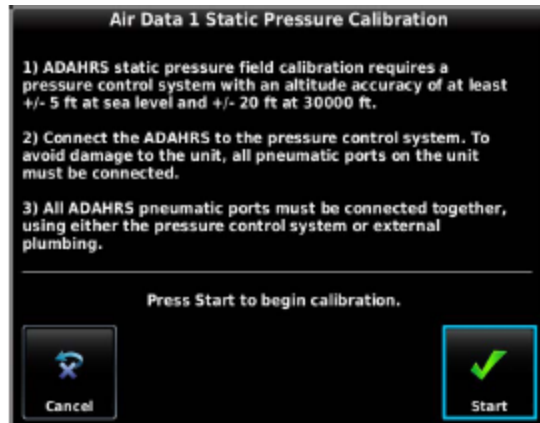

Figure 7-9 – Static Pressure Calibration Instructions

- At each calibration point (sea level, 10K, 20K, and optionally 30K ft), the display will present a screen that allows time to establish the calibration pressure before continuing.

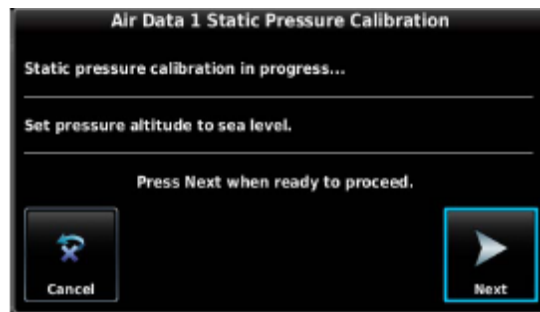

Figure 7-10 – Static Pressure Calibration in Progress

- Select "Next" to continue and calibrate each pressure.
- During the calibration at each pressure, the pressure must be held constant for 30 seconds for the calibration step to be successful. The calibration may be cancelled at any point should the test setup require adjustment before repeating.
- When the static pressure calibration is complete, a status screen will show that the procedure was successful.

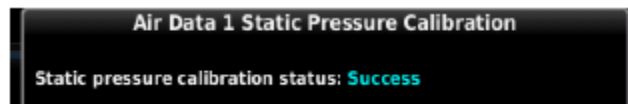

Figure 7-11 – Static Pressure Calibration Completion Status

#### 7.2.1.4 Engine Run-up Vibration Test



**NOTE**

*The Engine Run-Up Vibration Test is required for all installations to validate the vibration characteristics of the installation. The ADAHRS Unit Orientation and Pitch/Roll Offset Compensation (Section 7.2.1.1) are not required prior to this procedure.*

- Power on the PFD in configuration mode if it is not already in configuration mode.
- Select the ADAHRS Calibration Page.
- Ensure that all the required status boxes are checked.
- Select Engine Run-Up Test.

5. Ensure that the aircraft has been properly positioned per the on-screen instructions, then select the Start button to begin the test.
6. Gradually increase power from idle to full-throttle and back to idle over the course of one to two minutes; the test data is displayed as the test progresses.

**NOTE**

*If failures are indicated, the engine run-up test may be repeated up to three times. If the test does not pass after three attempts, the installation should be considered unreliable until the source of the vibration problem is identified and remedied. If the engine run-up test fails repeatedly, record the values that are reported to be out of range for future reference.*

7. Select the Done softkey when engine run-up has been completed; the test results will be displayed.
8. Ensure that test results indicate Passed, then select the Done button to return to the ADAHRS page.

The following are potential causes for failure of the engine run-up test:

- Excessive flexing of GSU 25D with respect to airframe.
- Vibration or motion of the GSU 25D caused by neighboring equipment and/or supports.
- Mounting of GSU 25D at a location that is subject to severe vibrations such as near engine mounts.
- Mounting screws and other hardware for GSU 25D and/or GMU magnetometer not properly attached.
- GSU 25D connector not firmly attached to unit.
- Absence of recommended mounting support.
- Cabling leading to the GSU 25D not firmly secured to supporting structure.
- An engine/propeller combination that is significantly out of balance.

**NOTE**

*Some aircraft may have difficulty passing this test if performed in windy conditions. Windy conditions do not provide evidence that the test would otherwise pass successfully; an actual pass is required before the installation can be considered adequate.*

### 7.3 GMU 11 Magnetometer

Reference Section 7.2.

### 7.4 GTP 59 Temperature Probe

#### Original GTP 59 Reinstalled

No software or configuration loading is required when an original GTP 59 is reinstalled.

#### New, Repaired, or Exchange GTP 59 Installed

If a new, repaired, or exchange GTP 59 is installed, no software or configuration required.

#### 7.4.1 GTP 59 Testing

1. Verify OAT operation by observing the PFD for a valid value for OAT.
2. Apply heat to the GTP 59 probe and observe OAT value rises by at least 5° Celsius.

### 7.5 GAD 27

#### Original GAD 27 Reinstalled

No software or configuration loading is required if the removed GAD 27 is reinstalled. Continue to Section 7.5.1.

New, Repaired, or Exchange Display(s) Installed

If a new, repaired or exchange GAD 27 is installed, the correct software will be loaded automatically by the G3X GDU when power is applied to the system.

### 7.5.1 GAD 27 Testing

Apply power to the aircraft and with all the circuit breakers closed, ensure **ECS FAIL** is not displayed on the GDU.

## 7.6 GEA 24(B) Engine and Airframe Unit

Original GEA 24(B) Reinstalled

No software or configuration loading is required if the removed GEA 24(B) is reinstalled. Continue to Section 7.6.1

New, Repaired, or Exchange GEA 24(B) Installed

If a new, repaired or exchange GEA 24(B) is installed, the correct software version and EIS configuration will be loaded automatically by the G3X GDU when power is applied to the system. Continue to Section 7.6.1.



### NOTE

*For most interfaces the GEA 24 and GEA 24B are interchangeable with the same wiring and configuration settings, however the GEA 24 interface to resistive fuel probes must use a pair of 2.2kΩ resistors and be configured as 'Voltage' interfaces (refer to Garmin SB 2134 and Installation Manual Rev.9 or later). If a GEA 24 is replaced by a GEA 24B, any fuel quantity interfaces to resistive probes must be recalibrated regardless of whether the 2.2kΩ resistors in the harness are retained or removed. For new installations with a GEA 24B, the resistors are not required, reference the STC Installation Manual Rev 14 (or later).*

### 7.6.1 GEA 24(B) Test

Verify all engine instruments are displayed and indicate valid values and markings. Reference Section 8.12 for checkout procedures.

## 7.7 GAD 29B/29D

Original GAD 29B/29D Reinstalled

No software or configuration loading is required if the removed GAD 29B/29D is reinstalled. Continue to Section 7.7.1.

New, Repaired, or Exchange GAD 29B/29D Installed

If a new, repaired or exchange GAD 29B/29D is installed, the correct software version will be loaded automatically by the G3X GDU when power is applied to the system. Continue to Section 7.7.1.

### 7.7.1 GAD 29B/29D Testing

Verify external LRUs that are connected to the GAD 29B/29D such as compatible navigators and non-Garmin autopilots are operating as intended:

1. GPS receiver check (Section 8.3)
2. Nav receiver check (Section 8.4)
3. Non-Garmin Autopilot interface check (Section 8.16)

## 7.8 GDL 5XR

### Original GDL 5XR Reinstalled

No software or configuration loading is required if the removed GDL 5XR is re-installed. Continue to Section 7.8.1

### New Repaired or Exchange GDL 5XR Installed

If a new repaired or exchange GDL 5XR is installed, the software will be loaded to the unit automatically by the G3X GDU when power is applied to the system. Continue to Section 7.8.1

## **7.8.1 GDL 5XR Functional Check**

Perform functional tests as applicable in Section 8.

1. Activate SiriusXM Radio and Weather (Section 7.14) – for newly installed GDL 51R/52R.
2. ADS-B Traffic interface check (Section 8.5) (GDL 50R/52R).
3. GDL 51R/52R SXM weather check (Section 8.10).
4. GDL 51R/52R SXM audio interface check (Section 8.11).

## **7.9 GTR 20 Remote-Mount VHF COM**

### Original GTR 20 Reinstalled

No software or configuration loading is required when an original GTR 20 is reinstalled.

### New, Repaired, or Exchange GTR 20 Installed

If a new, repaired, or exchange GTR 20 is installed, the software will be loaded to the unit automatically by the G3X GDU when power is applied to the system.

## **7.10 GTR 200B VHF COM**

### Original GTR 200B Reinstalled

No software or configuration loading is required when an original GTR 200B is reinstalled.

### New, Repaired, or Exchange GTR 200B Installed

If a new, repaired, or exchange GTR 200B is installed, the software will be loaded to the unit automatically by the G3X GDU when power is applied to the system.

### **7.10.1 GTR 200B Test**

Verify proper operation of the GTR 200B audio panel. Reference Section 8.14 for checkout procedures.

## **7.11 GMA 245R Audio Panel**

### Original GMA 245R Reinstalled

No software or configuration loading is required when an original GMA 245R is reinstalled.

### New, Repaired, or Exchange GMA 245R Installed

If a new, repaired, or exchange GMA 245R is installed, the software will be loaded to the unit automatically by the G3X GDU when power is applied to the system.

### **7.11.1 GMA 245R Test**

Verify proper operation of the GMA 245R audio panel. Reference Section 8.5 for checkout procedures.

## **7.12 GAP 26 AOA Probe**

### Original GAP 26 Reinstalled

No software or configuration loading is required when an original GAP 26 is reinstalled.

### New, Repaired, or Exchange GAP 26 Installed

If a new, repaired, or exchange GAP 26 is installed, no software or configuration required.

## 7.12.1 GAP 26 Testing

Reference Section 8.18 for checkout procedures.

## 7.13 G3X Software Information

All software files are certified by Garmin and are considered part of FAA-approved Type Design data. System software version 8.00 and later are approved for this STC.

The installer shall create this software loader card by downloading the approved software image in accordance with Section 7.13.1.



### NOTE

*G3X system software loaded via the GDU includes the latest approved software for all G3X LRUs and also includes software for the G5 standby instrument, GSA 28 autopilot servos, and the GMC 507 mode controller. The GTR 200B features a dedicated microSD slot for software updates, however this should not be used to load software when installed with G3X. If the G5 AML STC (SA01818WI) has an approved software version that is later than the one included with the G3X software, the later software version can be loaded directly into the G5 standby instrument.*



### NOTE

*Only SanDisk brand 8GB SD cards or smaller are recommended for use with the G3X system. If another brand of card is used and software loading problems occur, replace the card with a SanDisk brand card and reattempt the software load.*

### 7.13.1 Software Loader Card Creation

The software image is an executable self-extracting file which builds the correct file structure onto an SD card for use in loading software to the G3X. To obtain the current file, follow the procedures outlined below.

1. Go to [www.garmin.com](http://www.garmin.com) and navigate to the G3X Touch for Certificated Aircraft page, then click on the 'Software' link. Do not download software from the Experimental Aircraft web page.
2. Insert a FAT32-formatted (empty) SD card in to the card reader.
3. Double-click the .exe file to download the self-extracting update file onto the hard drive. A window similar to the image below will pop-up while extracting.

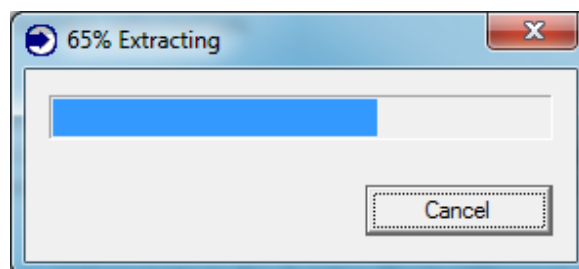

### NOTE

*When the extraction begins, the program automatically deletes all current files on the SD card and copies the selected files to it, regardless of the file format on the SD card. Ensure files are not necessary or card is empty before proceeding.*



- When extraction is complete, a window similar to one below will appear on the screen. Verify "GDU 4xx" is correct and an SD card is in the card reader, and then select "Next". Follow instructions provided by the installer application.



- Select from the drop-down list the correct drive letter of the SD card to be used for the update. Click next.

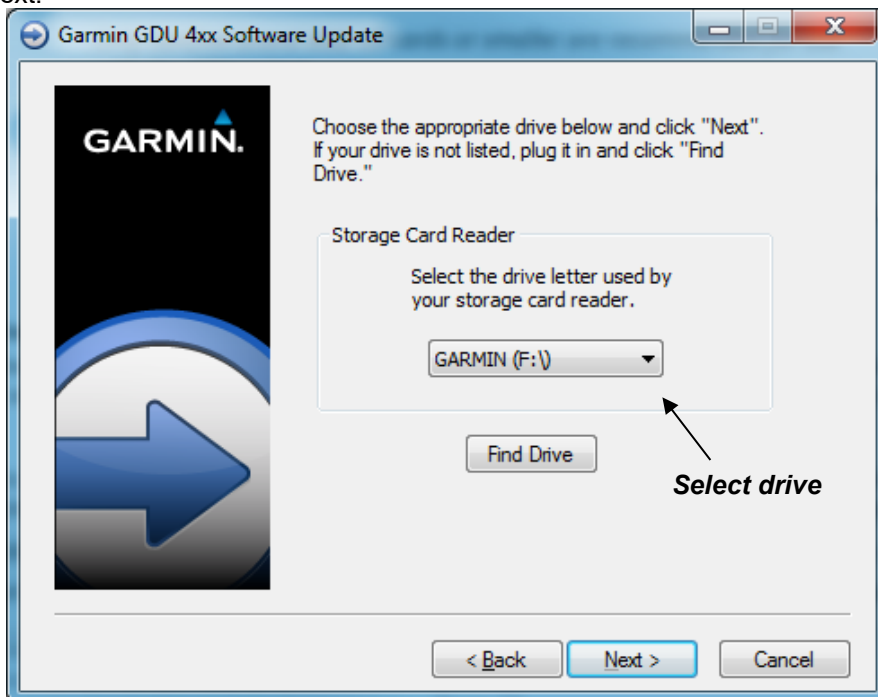

- A window will pop-up on the screen to indicating file progress.

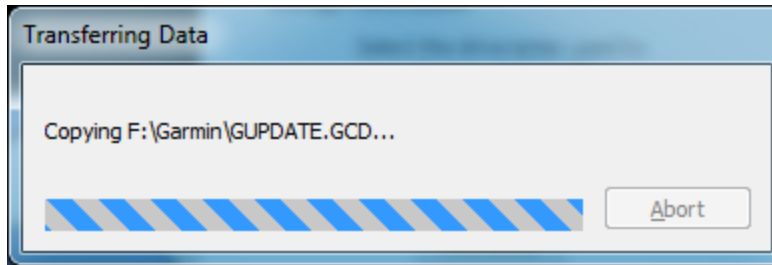

- Once successfully completed, a message/window similar to below will pop-up. Click Finish to finalize SD card.



- Remove SD card from card reader.



**NOTE**

*If necessary, 'eject' or un-mount the SD card prior to removal.*

**7.13.2 Software Loading Procedure**

Software loading is performed in normal mode. Obtain the software loader card as formatted and loaded with software per section 7.13.1. This section describes the procedures needed to load software to Garmin LRUs as part of configuring the G3X system for use.



**NOTE**

*Perform software updates on the ground only and remain on the ground while a software update is in progress*

**7.13.2.1 GDU Software Loading Procedure**

- Connect external power to the aircraft to energize the aircraft and avionics electrical buses.



**CAUTION**

**DO NOT RELY ON THE AIRCRAFT BATTERY TO LOAD SOFTWARE. DO NOT USE A BATTERY CHARGER AS AN EXTERNAL POWER SOURCE.** Power loss during a software upgrade may cause an LRU to become corrupted and unresponsive requiring replacement.

2. Power on the PFD in normal mode, then insert the properly formatted SD card into the SD card slot.



**NOTE**

*It is also acceptable to insert the SD card before powering on the unit.*

3. A Software update window will appear on the screen; select YES to begin the update. Figure 7-12 is an example image and may not represent the current software version.

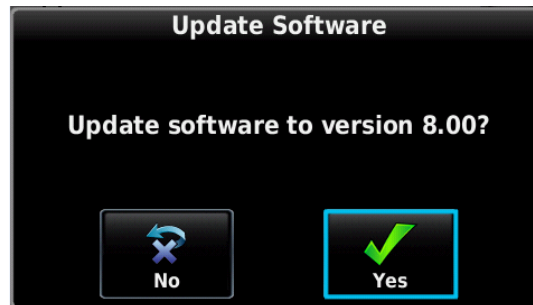

**Figure 7-12 – Update Software Window (Example)**

4. The unit will reboot, then GDU software update will begin automatically.
5. Ensure power is not removed while the update is being performed. The screen will display progress of the software load.
6. The unit will reboot after the update is complete.
7. Software update of other G3X LRUs will begin and a “Software update in progress- Do not remove power” message will be displayed on the message window. Touch **Messages** to view message and progress. The message will be removed once software loading to G3X LRUs is completed.

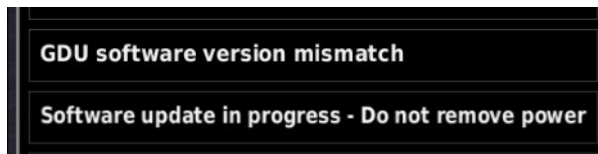

8. Repeat steps 1 through 5 on all other installed GDUs. A “GDU software version mismatch” message will be displayed until software has been loaded on all GDUs .

**7.13.2.2 LRU Software Loading Information**

G3X LRUs (except for GDUs) will automatically receive software updates from the PFD following a software update. Software for the G5 standby instrument, GSA 28 autopilot servos, and GMC 507 autopilot mode controller (if installed) is also updated automatically by the PFD. This process may take up to ten minutes for all LRUs connected to the high-speed CAN bus. The GDL 5XR is connected via RS-232 and may take up to 30 minutes to update software.



**NOTE**

*Approved software for PMA GDL 5XR units can only be loaded via the G3X GDU. The ability to update GDL 5XR software via Bluetooth connections has been disabled for PMA GDL 5XR units.*

Progress of LRU software updates can be monitored using the System Information page in configuration mode. In normal mode, touching the flashing amber 'Message' indication at the bottom of the GDU will bring up a system message 'Software update in progress – Do not remove power' which will persist until all LRU software updates are complete. Functionality provided by an LRU will be unavailable during a software update, therefore, all LRU software updates should be allowed to complete before flight after a GDU software update.

The current LRU software versions included with a GDU software update can be found in the change notes on the software download page.

### **7.13.3 Software Load Confirmation**

Perform software load confirmation after the software has been loaded to the G3X GDU(s) and LRUs.

1. Start the G3X GDUs in configuration mode (reference Section 3.2.2) as required.
2. Use the Touch Panel or a Move Selector Knob to select and view the System Information Page.
3. Ensure there is a green checkmark  next to all installed G3X LRUs.
4. Scroll the Device List box and select device's info by using the Touch Panel or a Move Selector Knob as necessary to verify the software and version numbers installed in the system.

### 7.14 Activation of GDL 51R/52R SiriusXM Radio and Weather

Before SiriusXM Weather and Radio is accessed, service must be activated by SiriusXM. Service is activated by providing SiriusXM with a Radio ID. Following the following activation steps.

#### Activation Steps

1. Contact SiriusXM at 1-855-796-9847 or at [www.siriusxm.com/sxmaviation](http://www.siriusxm.com/sxmaviation) to activate.
2. Obtain the Radio ID from the data tag on the unit or from the Datalink page in normal mode. To access the datalink page on the GDU, press “MENU” key twice for the main menu, then select Data Link.
3. Position the aircraft in an area with an unobstructed view of the southern sky. It is highly recommended that the aircraft be positioned outside and at least twenty five feet away from the hangar.
4. Connect an external power unit and apply power to the aircraft and avionics.
5. Navigate to the Data Link page in the main menu section and verify signal quality has green bars.
6. When the subscribed product is displayed by “Service Level”, the activation is complete. For example, in the screenshot below “Pilot Pro” is the subscribed product.



#### NOTE

*Do not remove power from the aircraft during the activation process.*



Figure 7-13 – Data Link Page

## 8. SYSTEM RETURN TO SERVICE PROCEDURE

This section provides checkout procedures to be completed after maintenance and/or repair has been performed in accordance to this manual, in order to verify the proper operation and function of G3X Touch systems.

Perform the procedures as applicable to the specific installation. Procedures not applicable may be skipped.

### 8.1 Recommended Test Equipment

The following test equipment is recommended to conduct and complete all post installation checkout procedures in this section:

- Ground power cart (capable of supplying power to the aircraft systems and avionics)
- Calibrated Air data test set
- Calibrated VHF NAV test set
- Low resistance ohmmeter
- Calibrated Digital Level
- Digital Multi-Meter (DMM)
- Calibrated Optical Tachometer

#### 8.1.1 LRU Status and Software Check

Perform LRU status and software check. The “System Information” page in the configuration mode of the GDU 4X0 PFD has a “Devices Online” tab that reports the status of installed LRU’s and their currently installed software part numbers and versions. The icon/checkbox next to each LRU reports a green checkmark, a ‘red x’ or blank checkbox to indicate the status of each LRU as described in Table 8-1.

To access the System Information Page, perform the following steps on the primary GDU:

1. In configuration mode, select the System Information Page. Scroll the Device List box and the selected device’s info by using the Touch Panel or a Move Selector Knob.
2. Verify that all LRUs connected or configured to each display have a green indicator and correct software part numbers and version numbers are reported.
3. Press the Back key to return to the Configuration Mode page when finished. Return the GDU to normal mode.

**Table 8-1 – LRU Status Indicators**

Color	LRU Condition
Green	The LRU is online & no faults found.
Red ‘X’	The LRU is online & a fault, warning, or error has been detected.
Blank	The LRU is not online.

## 8.2 Transponder Check

The GNX 375, all GTX 335(R)/345(R) transponders, and GTX 33/33ES/330/330ES transponders with software version 8.00 or later are compliant with RTCA/DO-181D, which specifies that the selection of transponder ALT and GND modes may not be controlled by the pilot. To allow the transponder to be operated in ALT mode while on the ground, for the purposes of performing periodic testing in accordance with the requirements of 14 CFR Part 91.413, a special transponder ground maintenance test mode is provided.

To access ground maintenance mode in a G3X Touch system:

1. Access the Transponder page, press the Menu key twice to access the main menu.
2. On the Main menu, select Setup to access setup page.
3. On the Setup page, select XPDR to access the transponder page.
4. On the transponder page, select “Enabled” under Ground Maintenance Test to force the transponder into ALT mode.



**Figure 8-1 – Transponder Setup Page (Normal Mode)**

Transponder ground maintenance mode will be cancelled following a power cycle, or if the aircraft is determined to be airborne.

## 8.3 GPS Receiver Check

### 8.3.1 GPS Receiver Signal Acquisition Test

The following steps constitute a simple test of the GPS receiver’s ability to acquire a GPS signal from satellites. This test needs to be performed outside, away from obstructions such as buildings, unless a known working GPS signal repeater has been installed in the hangar for this type of testing.

1. Power on unit in normal mode and select the Info Page.
2. Verify that the GPS receiver is functional and able to calculate its present position

### 8.3.2 GPS Receiver COM Interference Test



#### NOTE

GPS Status may also be monitored on the Info page in normal mode. The signal strength bars are a real-time representation of GPS signal strength which may be useful for troubleshooting a failed COM interference test.

This test must be conducted outside, as the use of a GPS repeater inside a hangar may result in a failed test. After the preceding signal acquisition test has been completed successfully, perform the following steps:

1. Apply power to the aircraft and G3X system and allow systems to initialize and the G3X system and/or GPS navigator (if installed) to acquire sufficient satellites for a GPS solution.
2. On the MFD (in dual GDU installations) or on the multi-function pane in split format mode (in a single GDU (PFD) installation); navigate to the info page to view the GPS status.
3. Monitor GPS status on the Main Page. Possible GPS status indications include:
  - No Antenna
  - Autolocate
  - Lost GPS Fix
  - 2D GPS Fix
  - 3D GPS Fix\*
  - Searching the Sky
  - Acquiring
  - No GPS Fix
  - 2D Differential
  - 3D Differential\*

*\*Indicates valid GPS position fix for this test*

4. Select 121.150 MHz on the COM transceiver.
5. Transmit for a period of 30 seconds while monitoring GPS status.
6. During the transmit period, verify that GPS status does not lose a valid GPS position fix on the Main Page in configuration mode.
7. Repeat steps 3 through 5 for the following frequencies:
  - 121.175 MHz
  - 121.200 MHz
  - 131.250 MHz
  - 131.275 MHz
  - 131.300 MHz
8. Repeat steps 3 through 6 for other installed COM transceivers if applicable.
9. If an installed COM supports 8.33 MHz channel spacing, repeat steps 3 through 5 while transmitting for a period of 35 seconds, for the following frequencies:
  - 121.185 MHz
  - 121.190 MHz
  - 130.285 MHz
  - 131.290 MHz
10. Repeat step 8 for other installed COM transceivers supporting 8.33 MHz channel spacing if applicable.

This COM interference test should be repeated if a second GDU is installed in the aircraft and paired with GPS antenna.



### 8.3.3 GPS Receiver Interface Check



#### NOTE

*GPS satellite reception is required for the following steps. Perform the test in an outdoor area with a clear view of the sky. The check may also be performed in a hangar with a good known GPS repeater.*

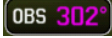
1. Verify the PFD is in Normal mode.
2. On the PFD options page under FPL Source, select “External GPS”.
3. On the PFD options page under CDI Source, select “GPS” (or “GPS1”) as the navigation source.
4. Verify the external GPS1 Navigator is powered on and if dual GPS navigators are installed, ensure the second GPS navigator (GPS2) is powered off.
  - a. For a GPS 175, GNX 375, GNS 4XXW/5XXW series or GTN 6XX/7XX series navigator, while on the power-up self-test page, verify that the PFD CDI displays the correct lateral and vertical deviation information.
  - b. For a GNS 480 unit, while it is going through its power-up sequence, verify that the PFD CDI displays the correct lateral and vertical deviation information.
5. Continue in normal mode after self-test and wait until the navigator acquires a position before proceeding.
6. Review the active alerts on the PFD (if any) and verify that there are no alerts, service soon, or service required alerts associated with the GPS unit.
7. Create or activate a flight plan on the GPS navigation source.
8. Verify that the active waypoint displayed in the PFD WPT field of the GDU 4X0 is the same as the active waypoint displayed on the navigator.
9. On the GPS navigator, enter OBS mode.
10. When OBS mode is entered on navigator, the course (CRS) field  on the GDU will activate and change to OBS on a lighter background , and knob that has been configured for course will be activated to change the course.
11. Adjust the course (OBS) using the configured PFD knob. Course may also be changed using the touch screen by pressing the OBS/CRS field and entering the value using the pop-up keypad.
12. Verify that the course to the active waypoint changes on the navigator as the PFD course pointer is rotating.
13. Exit OBS mode on the navigator.
14. If dual GPS receivers are installed power off GPS 1 and power on GPS 2. Select GPS2 on the CDI and repeat the GPS interface check (Steps 1-13).

### 8.4 NAV Receiver Check

1. Verify the external NAV1 receiver is powered on and if dual NAV receivers are installed, ensure the second NAV receiver (NAV2) is powered off.
2. Tune the NAV receiver to a localizer frequency (it is not necessary that a valid localizer signal is being received).
3. Verify that the CDI on the PFD displays “LOC” (or “LOC1”/“LOC2” for installations with dual navigators). The CDI source field in PFD options page should also display “LOC” (or “LOC1”/“LOC2”).
4. If dual navigation receivers are installed, power off NAV 1 and power on NAV 2.
5. Repeat the steps 2 through 4 above.

## 8.5 Audio Panel Interface Check

An in-aircraft checkout may be performed in the aircraft on the ramp with known good microphone, headset, and avionics receivers.

### 8.5.1 Alert Volume Check

This check is performed with GDU in configuration mode to verify proper alert volumes for alert, message, AOA, and Alt Alert as applicable.

1. Apply power to aircraft with GDUs in configuration mode.
2. Connect a headset to the pilot's headset output jack and pilot's mic jack.
3. Navigate to the "Sound Configuration" page.
4. Select the "Test" button;
  - Verify proper sound volume is heard on the headsets.
  - Verify proper sound volume is heard on the cabin speaker (if installed).
5. Repeat step 4 for all applicable alerts.

### 8.5.2 Failsafe Operation Check

1. Remove power to the unit by pulling the AUDIO circuit breaker.
2. Connect a mono headset to the pilot's headset output jack and pilot's mic jack.



#### NOTE

*Use of a true mono headset is required for this test to ensure proper wiring even if a stereo jack is provided in the installation. Wiring left channel (tip contact) and right channel (ring contact) backwards will cause failsafe mode not to function with mono headsets. Use of a true mono headset is required for this test (not a stereo headset with a mono/stereo switch because headset manufacturers differ on how they accomplish this switching). This will guarantee the condition of the right channel (ring terminal) being shorted to the return (sleeve terminal) by the mono headset's plug. This short occurs because of the physical design of the headset plug contacts and is an inevitable consequence of plugging a mono headset into a stereo jack. During power-on operation, this short will not damage the audio panel.*

3. Verify that COM1 transceiver can be heard in the pilot's headset.
4. Verify that COM1 can key and transmit the pilot's mic audio by verifying received sidetone or checking reception of the transmission with another radio tuned to receive this transmission (verify Pilot PTT and mic operation is delivered to this transceiver).
5. Apply unit power by restoring the audio circuit breaker to the normal operating position.

### 8.5.3 Transceiver Operational Check

1. Perform a radio check by exercising the installed transceivers, microphone, microphone key, and audio over the headset.
2. Verify that communications are loud and clear and PTT operation is correct.

### 8.5.4 Intercom System (ICS) Check



#### NOTE

*Stereo headsets are recommended if stereo jacks are installed. If a monaural headset is used in a stereo jack, the audio panel's right channel output is shorted to ground by the mono headset's plug (the audio panel automatically detects the short and turns off the right channel). In the case of passenger positions wired in parallel, any stereo listener will lose right channel audio when another passenger plugs in a mono headset.*

1. Set the intercom to the ALL mode [Pilot and Crew LED off]
2. Plug in headsets at each ICS position.
3. Check Pilot and Copilot ICS positions for isolation and proper operation of volume controls.

### 8.5.5 Aircraft Receivers Check

1. Select the audio source corresponding to each installed avionics unit and check for audio over the headsets.

### 8.5.6 Bluetooth Music System Check

Use the following steps to Pair and wirelessly connect a Bluetooth equipped phone or tablet to the GMA 245R.

1. On the G3X GDU, select the “Audio Panel” page by selecting “Audio” on the data bar or by navigating to the Main Menu page, then select the “Audio Panel” button to display the “Audio/Intercom” page.
2. On the “Audio/Intercom” page scroll to the “Phone & Media” tab.
3. Select “Pair Device” to enable the GMA 245R to be discoverable for two minutes, or until a device is paired or connected. While discoverable the bar below “Pair Device” will be green and will change back to a gray bar once paired or a device is not paired within two minutes.
4. While discoverable, a Bluetooth enabled device (e.g., cellphone or tablet) can find and pair with the GMA. Refer to the device’s instruction manual for information on how to pair and connect to a new Bluetooth device.
5. Once paired, the appropriate details of the device paired will be displayed.
6. Select the “Music Input” tab and select “Music” (green bar will be displayed under “Music”).
7. Play music from a device using the Bluetooth connection or by controlling on the “Phone & Media” tab.
8. With the “Music” button selected and the Bluetooth music source selected, verify music is heard in the connected headsets and that the music volume field adjusts the volume in the headset.
9. Tune the COM Radio to the frequency of a local ground or air traffic control station.
10. From the “Intercom” tab, select “Radio Mutes Music”, and verify music is muted with a transmission from the tuned frequency.

### 8.5.7 Speaker Check

1. If a speaker was installed, select SPKR and receive COM audio on the selected COM. When the speaker is selected, the selected Receivers on the GMA (COM, NAV, AUX ) should be heard from the speaker.



#### NOTE

*To ensure the music audio is not being muted by ICS or by COM audio, disable radio and ICS muting. Also, deselect the PILOT or CREW buttons so that there is no ICS Isolation.*

### 8.5.8 Marker Beacon Operation (if installed)

1. Using a ramp tester, simulate the outer marker, middle marker and inner marker signals by following the test equipment manufacturer’s instructions. Verify that each marker audio signal is present over the pilot headset and cockpit speaker (if installed).
2. From the pilot headset position, verify that marker audio can be heard when selected.
3. Verify that the outer, middle, and inner annunciations appear on the G3X GDU when the corresponding signal is applied.



#### NOTE

*Outer Marker – Blue Lamp – 400 Hz (AM or received audio tone)  
 Middle Marker – Amber Lamp – 1300 Hz (AM or received audio tone)  
 Inner Marker – White Lamp – 3000 Hz (AM or received audio tone).*



#### NOTE

*For instructions to configure Marker RF threshold sensitivity and audio volume settings,*

see the Installation Manual for the avionics system to which it is integrated for User Interface control.

4. Verify that during HI SENS operation, the RF threshold is more sensitive (marker audio/indication occurs as a lower RF power) when in HI SENSE mode.



## 8.6 ADS-B Traffic Interface Check



### NOTE

The following steps may be performed as a ground check as long as the aircraft is within range of an FAA ground station with available targets of opportunity. If this is not the case, it is recommended that these checks be performed in flight within range of an FAA ground station.

If the installed system is configured to receive ADS-B In data through an interface with an ADS-B In capable unit (GNX 375, GTX 3X5 or GDL 50R/52R), the interface is verified as follows:

1. Verify the GDU is in normal mode.
2. Select the Traffic page on the home screen of the MFD or the multi-function pane on the PFD.
3. Turn on the interfacing ADS-B In capable equipment.
  - a. If the installation includes TAS/TCAS correlated traffic, turn on the TAS/TCAS source.
4. Make sure an amber NO DATA or TRAFFIC FAIL messages are not displayed over or below the “ownship” icon.
5. Make sure there are no FAIL annunciations in the upper left-hand corner of the traffic status window. Depending on installation either  or  should be displayed if ADS-B Interface is correct.
  - a. If the installation includes TAS/TCAS correlated traffic, verify that the TAS/TCAS status is either OPER or STBY.
6. Observe targets of opportunity from ADS-B equipped aircraft, or an FAA ground station.
7. Apply power to any installed L-band equipment such as transponders, DME or TCAS, ensure there is no interference with ADS-B data reception.

### 8.6.1 TCAS Traffic Interface Check

1. Verify the GDU is in normal mode.
2. Select the Traffic page on the home screen of the MFD or the multi-function pane on the PFD.
3. Verify that no TAS/TCAS failure annunciations (“NO DATA”, “TRFC FAIL”, “NO TRFC DATA”, “DATA FAILED”, “FAILED”) are shown on the traffic map.
4. In the upper left corner of the Traffic Map page, verify that the Traffic Status is either TAS/TCAS: OPER or TAS/TCAS: STBY (“TIS: FAIL” or “TAS/TCAS: FAIL” must not be displayed).
5. Select the Traffic Status button and change the mode between Operate and Standby.
6. Verify that the mode of the traffic system is updated accordingly.
7. Put the traffic system in Standby mode.
8. Initiate a traffic system self-test by selecting the Test button at the bottom of the page. Note: The Self-Test button will not be selectable if the traffic system is not powered on or is in a failed status.
9. Verify that the traffic system runs a self-test and the self-test traffic pattern is displayed.

### 8.7 TIS-A Traffic Interface Check

If a Garmin GTX 3X5(D) transponder is connected to the G3X Touch system and no other traffic systems covered in this manual is installed, the traffic interface is verified as follows:

1. Verify the PFD is in normal mode. For a dual GDU installation verify both are in normal mode, and test is performed on the MFD.
2. For single GDU installations, select the Traffic page in split screen format on PFD.

3. Turn on the GTX 3X5(D) by pressing ALT on the GTX.
4. Verify that the Traffic Status is not TIS Fail.
5. Verify that the amber NO DATA is not displayed over the “ownship” symbol.
6. Verify that the Traffic Status is in Standby mode. (i.e., TAS should not be displayed).
7. Attempt to place the system in Operate mode, if the aircraft is within TIS-A coverage, the system will display Operate, if the aircraft is not within TIS-A coverage, the unit will display ‘Unavailable’.

**8.8 WX-500 Stormscope Interface Check**

1. Verify the GDU is in normal mode. For a dual GDU installation verify both are in normal mode.
2. Allow up to five minutes for the system to obtain a GPS position fix.
3. On the PFD/MFD (GDU that Stormscope is connected to) Map page, select MENU.
4. Touch Lightning Detection button on the screen to activate the lightning system.
5. Verify bar on the lower part of the ‘button’ turns to green. On the Map page, the following symbol  will be displayed on the lower left corner of the map.
6. From the Map page, press the MENU button, and select Set Up Map.
7. Scroll tabs as necessary to the Lightning Tab.
8. On the Lightning tab, ensure ‘On’ is selected under Lightning Detector Data field.
9. Select the Self Test button to determine if there are any faults on the WX-500 system.
10. Select the desired range to be displayed under Lightning Symbol field.



**Figure 8-2 – Lightning Tab**

11. Select between Cell and Strike modes under Lightning Detector Mode field.
12. Refer to the WX-500 *Installation Manual* for specific post installation test procedures to simulate and view strike data on the Map page.

**8.9 FIS-B Weather via ADS-B In**



**NOTE**

*The following steps may be performed as a ground check as long as the aircraft is within range of an FAA ground station. If this is not the case, it is recommended that these checks be performed in flight within range of an FAA ground station.*

1. Verify the G3X Touch EFIS is in normal mode.
2. Verify the GPS and FIS-B source is in normal mode.
3. Allow up to five minutes for the system to obtain a GPS position fix.
4. On each installed GDU, select the Weather page. If more than one data sources are installed, press MENU then select the FIS-B under the “Data Source” field, otherwise, the data source selection will be automatic.

**NOTE**

*It may take up to 10 minutes after power-on for the system to begin receiving FIS-B weather products.*

5. Verify there are no warnings displayed.
6. Push the GDU knob (right knob on GDU 460), then select several FIS-B weather products to display.
7. Verify at least one of the selected products displays a valid time stamp.
8. Verify there are no status fail messages regarding FIS-B weather.

**8.10 GDL 51R/52R SXM Weather Check**

SiriusXM weather and radio activation is required for this check, reference Section 7.14 for instructions.

Position the aircraft where there is a clear view of the southeastern or southwestern sky. XM Satellite Radio satellites are located above the equator over the eastern and western coasts of the continental United States.

1. Verify the G3X Touch system is in normal mode.
2. Allow up to five minutes for the system to obtain a GPS position fix and the GDL 5XR to obtain data.
3. On each GDU, select the Weather page from the multi-function pane.
4. Verify there are no warnings displayed.
5. Push the GDU knob (right knob on GDU 460) to display weather data page.
6. Verify weather data associated with the subscribed service level is available. Examples of weather data available are "NEXRAD, METAR, Winds Aloft, Lightning etc.

**8.11 GDL 51R/52R SXM Audio Interface Check**

This procedure only verifies correct installation and activation of G3X Touch system functions. It does not activate the GDL 5XR Series XM data link radio. SiriusXM weather and radio activation is required for this check, reference Section 7.14 for instructions.

1. Position the aircraft where there is a clear view of the southeastern or southwestern sky. (XM Satellite Radio satellites are located above the equator over the eastern and western coasts of the continental United States.)
2. Verify the G3X Touch system is in normal mode.
3. Allow up to five minutes for the system to obtain a GPS position fix and the GDL 5XR to obtain data.
4. On each GDU's Multi-function pane, select the SXM page.
5. Verify Audio signal bars are in the Green and that the displayed subscription level is accurate.
6. Verify that under Artist "XM DATA LINK FAIL" is not displayed.
7. Using the inner knob, scroll the channels.
8. Verify that music plays on multiple channels.

**8.12 EIS Check**

This section contains procedures to verify proper installation, operation, and gauge markings of the EIS. Complete the following applicable checkouts if EIS sensor or gauge settings may have been affected by maintenance.

**CAUTION**

*Check hose routing for sharp bends. Check sensors and fittings for leaks during and after engine run-up and correct prior to flight.*

### 8.12.1 EIS Annunciator Light Check (If installed)

If EIS annunciator lights are installed on a G3X Touch system with a standalone MFD, perform the procedures below in configuration mode to verify proper operation of the annunciator discrete outputs from the GEA:

1. Apply power to the aircraft.
2. Press and hold down the MENU key while powering on the GDU 4X0, until the Configuration Mode page appears.
3. Select the “Systems Information” page.
4. On the “Device List” tab, navigate to the EIS field.
5. On the “Engine Information System Info” tab, select the “Annunciator Test” button while observing the EIS annunciator lights.
  - Verify the lights illuminate.
6. Remove power from the aircraft.



**NOTE**

*If the annunciator lights do not illuminate, verify lamp operation (Section 8.12.4). If lamp check is good, remove power from the aircraft and inspect wiring.*

### 8.12.2 EIS Ground Check

Conducted with the engine off and at ambient temperature.

1. Verify the G3X Touch system in normal mode.
2. Navigate to the engine page on the MFD or multi-function pane of the PFD in split format.
3. Verify that no red or amber X marks are present on any EIS gauge.
4. EGT/CHT- Apply heat to each EGT/CHT sensor to verify the corresponding cylinder is connected correctly.



**NOTE**

*If the temperature decreases when heat is applied, the wire polarity may be reversed.*

5. Oil and fuel pressure(s)- Verify the corresponding gauge(s) read 0 +/-1 PSI.
6. Manifold Pressure - With engine not running, verify that the Manifold Pressure Gauge reads ambient pressure +/-1 inHg. To determine ambient pressure at your location, multiply the current altimeter setting by the Field Elevation (FE) Factor below. For example, if the altimeter setting is 30.10 and the field elevation is 1700 ft, the FE Factor is 0.9400 (30.10 x 0.9400 = 28.29 local ambient pressure). If out of tolerance, replace the Manifold Pressure sensor.

Field Elev.	FE Factor		Field Elev.	FE Factor		Field Elev.	FE Factor
-500	1.0182		2000	0.9298		4500	0.8477
-400	1.0145		2100	0.9264		4600	0.8445
-300	1.0109		2200	0.9230		4700	0.8414
-200	1.0073		2300	0.9196		4800	0.8382
-100	1.0036		2400	0.9162		4900	0.8351
0	1.0000		2500	0.9129		5000	0.8320
100	0.9964		2600	0.9095		5100	0.8289
200	0.9928		2700	0.9062		5200	0.8258
300	0.9892		2800	0.9028		5300	0.8227

Field Elev.	FE Factor		Field Elev.	FE Factor		Field Elev.	FE Factor
400	0.9856		2900	0.8995		5400	0.8196
500	0.9821		3000	0.8962		5500	0.8165
600	0.9785		3100	0.8929		5600	0.8135
700	0.9750		3200	0.8896		5700	0.8104
800	0.9714		3300	0.8863		5800	0.8074
900	0.9679		3400	0.8830		5900	0.8043
1000	0.9644		3500	0.8798		6000	0.8013
1100	0.9609		3600	0.8765		6100	0.7983
1200	0.9574		3700	0.8733		6200	0.7953
1300	0.9539		3800	0.8700		6300	0.7923
1400	0.9504		3900	0.8668		6400	0.7893
1500	0.9469		4000	0.8636		6500	0.7863
1600	0.9435		4100	0.8604		6600	0.7833
1700	0.9400		4200	0.8572		6700	0.7804
1800	0.9366		4300	0.8540			
1900	0.9332		4400	0.8508			

If the manifold pressure appears slow to respond or is reporting an incorrect value during operation, check the Garmin Restrictor fitting (if installed) to ensure the orifice is not blocked. Refer to Section 6.6.1.1.1 for cleaning procedure.

7. Current or Voltage- Verify the corresponding gauge(s) display the correct measurement(s).
8. Fuel Quantity- Verify the indicated fuel quantities are accurate for each tank when the aircraft is leveled in accordance with the aircraft manufacturers instructions.



#### NOTE

*The GEA 24 interface to resistive fuel probes must use a pair of 2.2kΩ resistors and be configured as 'Voltage' interfaces (refer to Garmin SB 2134 and Installation Manual Rev.9 or later). If a GEA 24 is replaced by a GEA 24B, any fuel quantity interfaces to resistive probes must be recalibrated regardless of whether the 2.2kΩ resistors in the harness are retained or removed. For new installations with a GEA 24B, the resistors are not required, reference the STC Installation Manual Rev 14 (or later).*

### 8.12.3 EIS Engine Run-Up Check

Always follow engine startup procedures as described in the Aircraft POH.



#### CAUTION

*If the engine indications are not within operating specifications shortly after starting, IMMEDIATELY shut down the engine and troubleshoot the problem. Failure to do so may cause engine damage.*

Obtain an optical tachometer to monitor propeller RPM.

1. Place the aircraft in an open and clear area appropriate for an extended engine run-up.



2. Follow the engine start-up procedure as outlined in the aircraft POH. Adhere to the required observations immediately following the start such as oil pressure within 30 seconds.
3. Verify the EIS RPM gauge(s) match the optical tachometer reading +/- 50 RPM.
4. Allow the engine to warm up and oil temperature to increase to at least 100°F.
5. Verify the alternator load meter (if installed) and battery charge/discharge ammeter (if installed) indicate a positive load.
6. Perform individual magneto checks as specified by the aircraft POH. If the RPM does not drop as expected when switching from both magnetos to one, the P-lead, ignition switch wiring, or magneto timing is incorrect. Discontinue the test immediately and repair the ignition system.
7. Verify all EIS readings are consistent with normal operation performance in accordance with aircraft type design, engine type design, and/or aircraft POH/AFM.
8. Verify the accuracy of the fuel flow indication.
9. Verify all installed sensors and fittings are free of leaks.

#### 8.12.4 EIS Annunciator Lamp Check (If installed)

Perform a check of the EIS annunciator lamps as follows:

1. Apply power to the aircraft.
2. Ensure the lens is not dimmed by rotating the lens holder counter clockwise.
3. Momentarily press the lens with light pressure, and verify light is illuminated.
  - If light does not illuminate, replace the lamp. Reference Section 6.14.1 for lamp replacement instructions.
4. Remove power from the aircraft.

#### 8.13 ADAHRS and Magnetometer Ground Checks

This section contains the ground checks that may be performed on the magnetometer for ADAHRS aspects of the G3X system.



##### CAUTION

*To avoid damaging the ADAHRS pressure sensors, the pitot and static ports and GAP 26 (if installed) must be connected to the test set. Note that the GAP 26 has drain holes on the underside of the probe which must be covered during the test.*

##### 8.13.1 Altimeter Check

The GDU 4X0 altitude displays must be verified per Title 14 CFR 91.411 and 14 CFR Part 43 Appendix E, with the following exception to 14 CFR Part 43 Appendix E, paragraph (b)(1):

- The tests of sub-paragraphs (iv) (Friction) and (vi) (Barometric Scale Error) are not applicable because the digital outputs of the GSU 25D are not susceptible to these types of errors.

This procedure is recommended when the GSU 25D is removed and reinstalled/replaced or the pitot and static system connections are disturbed.

##### 8.13.2 Pitot-Static and Airspeed Tape Settings Checks

The following section verifies the correct operation of the GDU 4X0 altitude and airspeed display functions. These tests require the use of a Calibrated Air data test set. When using a Calibrated Air data test set, only simulate normal aircraft operating conditions, as defined in the aircraft Type Data (POH/AFM) or other approved STC to avoid component damage.

Airspeeds above Vne should not be checked.

*The aircraft or instrument manufacturer's data should be referenced for tolerances for this test where available.*

1. Connect the calibrated air data test set to the aircraft.
2. Apply power to the aircraft.

3. Verify all self-tests pass on the main startup screen.
4. Using the air data test set, increase the airspeed until the PFD airspeed tape pointer is at the bottom of the white band (Vs0).
5. Verify that the pitot and static pressure settings used on the test set match what is displayed on the GDU.
6. On the pitot static test set, change the airspeed until the PFD airspeed tape pointer is at the bottom of the green band (Vs1).
7. Verify that the bottom of the green arc/band on the standby ASI and PFD airspeed tape are at the same airspeed value.
8. Change the airspeed until the PFD airspeed tape pointer is at the top of the white band (Vfe).
9. Verify that the top of the white arc/band on the standby ASI and PFD airspeed tape are at the same airspeed value.
10. Change the airspeed until the PFD airspeed tape pointer is at the top of the green band/bottom of the yellow band (Vno).
11. Verify that the top of the green arc/band on the standby ASI and PFD airspeed tape are at the same airspeed value.
12. Increase the airspeed to the upper red radial/top of yellow arc (Vne).
13. Verify that the red radial on the standby ASI and PFD airspeed tape are at the same airspeed value.
14. Starting at the current airspeed, decrease the airspeed to zero, stopping at each of the airspeeds listed in Table 8-2. verifying that the PFD and standby ASI airspeed values are within the tolerances indicated in Table 8-2.



**NOTE**

*The aircraft or instrument manufacturer's data should be referenced for standby tolerances, if available.*

**Table 8-2 – Airspeed Test Points**

Test Set (KTS)	Allowed Tolerance (+/- KTS)	Recorded Result GDU	Recorded Result for installed Standby ASI
50	5.0		
80	3.5		
100	2.0		
120	2.0		
150	2.0		

**8.13.3 Compass Swing**

After the Magnetometer Calibration Procedure is completed, a compass swing must be performed to verify the ADAHRS/GMU 11 heading accuracy.

1. Verify 'Auto Mag. Variation' is selected.
  - o With the PFD in Normal mode, navigate to the Position Setup Page (Menu → Main Menu → Setup → Position).
  - o Under Heading tab, ensure 'Auto Mag. Variation' is selected.
  - o Return to the main screen.
2. With the PFD in normal mode, all of the aircraft and avionics systems powered and operating normally, position the aircraft on a known compass rose at a heading 360° (North), or select a

level and magnetically clean location and use a sight compass to position the aircraft to a heading of 360° (North)

3. Record the HDG value displayed on the PFD as indicated in Table 8-3, below. Also record the heading displayed on the standby compass. Verify or correct the standby compass deviation card.
4. Repeat step 2 for each of the headings listed in Table 8-3.
5. Calculate the heading errors by subtracting the displayed (B) value from the actual (A) value for each of the headings in Table 8-3.
6. If all calculated heading errors displayed on the PFD are at or within +/-10° from the surveyed heading, the installation is acceptable, and no further work is required to correct the GMU 11 installation.
7. If a Heading Error (A-B) is greater than +/- 10°, calculate the average error by adding all errors and dividing by 12. This is the angle by which the GMU 11 must be physically rotated to correct the installation.
8. Modify the installation to rotate the GMU 11 by the amount calculated in the previous step. When looking down at the GMU 11, rotate clockwise for positive values, and counterclockwise for negative values.
9. After physically correcting the GMU 11 installation, repeat the procedures in Section 7.2.1.2 and 8.13.3.

**Table 8-3 – Heading Verification – ADAHRS Check**

Heading (A)	Displayed ADAHRS Heading (B)	Heading Error (A-B)	Standby Compass Heading
360° (North)			
30°			
60°			
90°(East)			
120°			
150°			
180°(South)			
210°			
240°			
270°(West)			
300°			
330°			

#### 8.14 GTR 20/200B Ground Checks



#### NOTE

*To enter configuration mode on the GTR 200B, remove power from the unit and with unit powered off, press and hold the SMALL knob and apply power by turning the PWR VOL knob clockwise. Release the SMALL knob when the display activates, and config mode is displayed.*

##### 8.14.1 Headset Tests Page (Configuration Mode) (GTR 200B Only)

The Headset Tests page allows the installer to test the operation of the headset outputs:

1. Enter configuration mode on the GTR 200B, from the Configuration Mode Home page, turn the LARGE Knob to highlight the Headset Tests page and press the SMALL Knob to display.

Stereo headsets with the stereo setting selected must be used with 3D audio. Stereo headsets are shipped set to mono. Make sure the headsets used for this test are set to the stereo position.

A true mono headset will work correctly with the GTR 200B, but only mono audio will be heard, and 3D audio will not be available. The GTR 200B will detect the mono headset and automatically switch to mono operation. A mono headset plug can be identified by the absence of the RING. Perform the below procedure to verify proper headset configuration.

2. Connect a stereo headset to the pilot headset position.
3. Move to the HEADSET TEST subpage.
4. Verify that none of the HS SHORT checkboxes are checked.
  - If the HS SHORT L checkbox is checked it is likely that there is an installation wiring problem.
  - If the HS SHORT R checkbox is checked it is likely that a mono headset is plugged in or there is an installation wiring problem.
  - If both the HS SHORT L and R checkboxes are checked it is likely that a stereo headset set to mono is plugged in.
  - If any of the HS SHORT checkboxes are checked, and no headset is plugged in, check for an installation wiring problem.
5. Use the SMALL Knob to move through the TEST TONE positions. The positions are:
  - PIL LEFT – A tone should be heard in the left ear speaker of the pilot headset.
  - PIL RIGHT – A tone should be heard in the right ear speaker of the pilot headset.
  - COP LEFT – A tone should be heard in the left ear speaker of the copilot headset.
  - COP RIGHT – A tone should be heard in the right ear speaker of the copilot headset.
6. Verify that the test tone is heard in the correct headset ear speaker and the tone is not heard in any other position.
7. Repeat steps 2 through 6 for the copilot headset position.

#### **8.14.2 COM Tests Page (Configuration Mode) (GTR 200B Only)**

The COM Tests page allows the installer to test the operation of the COM functions.

Perform the below procedure to verify proper COM configuration:

1. Enter configuration mode on the GTR 200B, from the Configuration Mode Home page, turn the LARGE Knob to highlight the COM Tests page and press the SMALL Knob to select the COM TESTS subpage.
2. Connect a headset to the pilot headset jacks.
3. Verify the following checkboxes are not checked:
  - TX – Indicates the radio is transmitting.
  - RX – Indicates the radio is receiving.
  - SQ – Indicates the radio squelch is overridden. Radio squelch can be overridden by pushing the volume knob.
  - LO VOLT - Indicates the radio input voltage is low. The radio will reduce TX power or stop transmitting completely depending on the voltage level.
  - HI TEMP – Indicates the transmitter temperature is high. If transmitter temperature is high the radio will reduce TX power until the temperature lowers.
  - TX AMPS – This is not a checkbox. This indicates how much current (in Amps) is supplied to the transmitter. When the GTR 200B is transmitting the current draw will be approximately 3.0 Amps under ideal load conditions. When the GTR 200B is not transmitting the current draw will be around 0.01 Amps.
4. If the LO VOLT checkbox is checked this indicates a low battery condition or wiring fault that is preventing the radio from receiving proper voltage. Correct this condition before proceeding with this test.
5. Select a frequency that is transmitting. An ATIS, ASOS, or other continuously transmitting frequency is a good choice. Frequency tuning works differently in configuration mode. The

SMALL Knob changes the highlighted frequency field and the LARGE Knob moves the highlighted field.

6. Verify the RX checkbox is checked, and the received audio can be heard in the headset.
7. Select a frequency that is safe for transmission. The antenna and coaxial cable must be properly connected to the radio before attempting to transmit.
8. Key the transmitter and verify the TX checkbox is checked while transmitting. If the checkbox does not check, there is a wiring fault. If the checkbox is always checked there is a wiring fault.
9. If the radio is tuned to a frequency that is appropriate for a radio check, one can be performed as part of this test.
10. If the copilot position is wired for transmission repeat steps 2 through 9 for the copilot position.

### 8.14.3 Receiver/Transmitter Check (Normal Mode)

Tune the unit to a local VHF frequency and verify the receiver output produces a clear and understandable audio output. Verify the transmitter functions properly by contacting another station and getting a report of reliable communications.

### 8.14.4 Alert Volume Check

This check is performed with GDU in configuration mode to verify proper alert volumes for alert, message, AOA, and Alt Alert as applicable.

1. Apply power to aircraft with GDUs in configuration mode.
2. Connect a headset to the pilot's headset output jack and pilot's mic jack.
3. Navigate to the "Sound Configuration" page.
4. Select the Test button
  - Verify proper sound volume is heard on the headsets.
5. Repeat step 4 for all applicable alerts.

## 8.15 Garmin GFC 500 Autopilot

For aircraft equipped with Garmin GFC 500 autopilot system, perform interface checkout of the autopilot in accordance with procedures outlined in *GFC 500 Part 23 AML STC Installation Manual 190-02291-00*.

## 8.16 Non-Garmin Autopilot Interface

Before proceeding with the autopilot interface tests, verify the G3X system and non-Garmin autopilot have been properly configured. For configuration instructions reference Appendix B.5. and the *G3X Touch EFIS Part 23 AML STC Installation Manual (190-02472-01)*. Only those interfaces which are directly affected by the G3X Touch STC are covered by this manual; if any other autopilot modifications were performed, they are outside the scope of this STC and must be checked in accordance with the autopilot installation manual.



### WARNING

*It is important that the PFD be properly configured in order to prevent damage to the autopilot computer.*



### NOTE

*The following procedures are general in nature and it may be necessary to reference the autopilot manufacturers testing instructions to allow the autopilot to be tested properly. A calibrated VHF NAV test set is required for some tests in this section.*

### 8.16.1 Autopilot Engagement Check

This section verifies that the autopilot can be engaged.

1. Verify the G3X Touch system is in normal mode. Allow the PFD to obtain a valid heading, attitude, altitude, and GPS location.

2. Verify the GPS navigator is in normal mode.
3. Engage the autopilot. If the autopilot cannot be engaged, troubleshoot using the instructions in the autopilot installation manual.
4. If step 3 was successful, disengage the autopilot.

### 8.16.2 Heading and Course Error Check

This section verifies that the heading and course error interface between the GDU 4X0 and autopilot computer is functional. For dual GDU G3X Touch installations, the following instructions apply only to the PFD.

#### 8.16.2.1 Heading Error

1. Verify the G3X Touch system is in normal mode.
2. On the PFD set the heading bug to the current aircraft heading.
3. On the PFD, verify HDG/CRS Valid.
4. Engage the autopilot in HDG mode.
5. Adjust the heading bug to the right.
6. Verify that the control yoke or stick moves to the right.
7. Adjust the heading bug to the left.
8. Verify that the control yoke or stick moves to the left.
9. Adjust the heading bug to the aircraft heading.
10. Disengage the autopilot.



#### NOTE

*If the control yoke or stick moves in the opposite direction of what is expected, reverse the LEFT/RIGHT HDG Polarity on the Autopilot Calibration page and continue the checkout process.*

#### 8.16.2.2 VOR Course Error

Some autopilot systems might not have course error capability; and this step is not necessary for those systems.

1. Apply power to the aircraft and aircraft systems and allow the aircraft systems to initialize.
2. Tune the VHF NAV to the NAV/COM Test Set frequency for VOR operation.
3. Set the Course pointer on the PFD HSI 15 degrees to the left of aircraft heading and ensure that the PFD CDI is displaying VOR navigation information.
4. Simulate a VOR signal with a "TO" course equal to the aircraft heading.
5. Slowly adjust the course pointer on the PFD CDI toward the aircraft heading until VOR captures.
6. Center PFD CDI course pointer on the aircraft heading.
7. Engage the autopilot in NAV mode.
8. Adjust the NAV ramp tester course and the PFD CDI course pointer 20 degrees to the left of current aircraft heading.
9. Verify that the flight controls move toward the left.
10. Adjust NAV ramp tester course to aircraft heading.
11. Adjust the NAV ramp tester course and the PFD HSI CDI course pointer 20 degrees to the right of current aircraft heading.
12. Verify that the flight controls move toward the right.
13. Adjust the NAV ramp tester course to aircraft heading.
14. Disengage the autopilot.

#### 8.16.2.3 Localizer

1. Tune the VHF NAV to the NAV/COM Test Set frequency for LOC operation.
2. On the NAV ramp tester simulate centered LOC needle presentation.
3. Set the Course pointer on the PFD HSI to the current aircraft heading.
4. Verify the PFD CDI displays centered deviation for LOC.

5. On the NAV ramp tester simulate 0.093 DDM Left LOC.
6. Verify PFD CDI deviation bar is one dot left.
7. Verify that the flight controls turn to the left.
8. On the NAV ramp tester simulate 0.093 DDM Right LOC.
9. Verify PFD CDI displays one dot right.
10. Verify that the flight controls turn to the right.
11. On the NAV ramp tester simulate centered LOC needle presentation.
12. Disengage the autopilot.

### 8.16.3 GPSS Course

This test is only performed for installations that are interfaced to a GPS navigation source and the interfaced autopilot did not previously have a GPSS function. Conduct this test with the aircraft positioned where it can receive GPS signal.

1. On the GPS navigator, enter a simple Direct-To flight plan with a waypoint that is on the current aircraft heading and select the PFD CDI to display GPS. If the navigator has the capability to enter user waypoints, a user waypoint can be entered to facilitate this test. It is suggested that the waypoint be within 5 miles of the current aircraft position for best results.
2. On the PFD, press the MENU button to display the 'PFD Options' page, and select GPSS. A green bar is displayed at the bottom of the GPSS box to indicate it is selected(enabled).
3. Verify the following:
  - On the PFD Attitude field
    - GPSS field is displayed to the right of the airspeed tape.
  - On the PFD CDI
    - The heading bug is a hollow cyan bug on the CDI.
4. On the navigator select OBS to enter GPS OBS mode.
5. Set the OBS course for the current aircraft heading (it is assumed the waypoint is on the current aircraft heading).
6. Engage the autopilot in HDG mode.
7. Adjust the OBS course 20 degrees to the left of current aircraft heading.
8. Verify that the flight controls move toward the left.
9. Adjust the OBS course 20 degrees to the right of current aircraft heading.
10. Verify that the flight controls move toward the right.
11. Adjust the OBS course to aircraft heading.
12. Disengage the autopilot.

### 8.17 G5 Miscompare Check

This test is only performed on installations with G5 ADI as a standby instrument.

1. Apply power to the aircraft and G3X system and allow G5 to initialize.
2. Verify heading, altitude and IAS values on the G3X PFD match the values on the G5, and heading, altitude and IAS miscompare messages are not displayed on the PFD.
3. Rotate G3X PFD knob that has been configured for controlling heading and verify “HDG xxx°” is displayed on the G5 and matches the value on the G3X PFD, and the heading bugs move at the same rate on both the G5 and G3X PFD.
4. Press the G5 knob then rotate to highlight “Heading” field, press the knob to make selection and rotate to adjust:
  - Verify the values on the heading field on the G3X PFD incrementally change at the same rate and values match the G5 ADI.
  - Verify the heading bugs move at the same rate on both the G5 and G3X PFD
5. Rotate G3X PFD knob that has been configured for controlling the altitude bug and verify the bugs move, values match and incrementally change at the same rate on both the G5 and G3X PFD altitude tape.
6. Press the G5 knob then rotate to highlight “Altitude”, press the knob to make selection and rotate to adjust:
  - Verify the altitude bugs move, values match and incrementally change at the same rate on both the G5 ADI and G3X PFD altitude tape.
7. Rotate G3X PFD knob that has been configured for controlling “Baro” and verify the barometric pressure and pressure altitude values incrementally change at the same rate and values match on both the G5 ADI and G3X PFD.
  - Verify the “Baro” field on the G5 changes to a cyan color and the digits change to black color but revert to black field with cyan digits, once the knob is no longer rotated.
8. Rotate G5 ADI knob and verify the barometric pressure and pressure altitude values incrementally change at the same rate and values match on both the G5 ADI and G3X PFD.
  - Verify the “Baro” field on the G3X PFD changes to a cyan color and the digits change to black color but revert to light background with cyan digits, once the knob is no longer rotated.

### 8.18 GI 275 Miscompare Check

This test is only performed on installations with GI 275 ADI as a standby instrument.

1. Apply power to the aircraft and G3X system and allow GI 275 to initialize.
2. Verify heading, altitude and IAS values on the G3X PFD match the values on the GI 275, and heading, altitude and IAS miscompare messages are not displayed on the PFD.
3. Rotate G3X PFD knob that has been configured for controlling heading and verify “HDG xxx°” is displayed on the GI 275 and matches the value on the G3X PFD, and the heading bugs move at the same rate on both the GI 275 and G3X PFD.
4. On the GI 275, tap the selected heading display box (lower left corner below the airspeed tape). Rotate the knob to adjust the selected heading:
  - Verify the values on the heading field on the G3X PFD incrementally change at the same rate and values match the GI 275.
  - Verify the heading bugs move at the same rate on both the GI 275 and G3X PFD.
5. Rotate G3X PFD knob that has been configured for controlling the altitude bug and verify when the bugs move, values match and incrementally change at the same rate on both the GI 275 and G3X PFD altitude tape.
6. Rotate G3X PFD knob that has been configured for controlling “Baro” and verify the barometric pressure and pressure altitude values incrementally change at the same rate and values match on both the GI 275 and G3X PFD.



- Verify the “Baro” field on the GI 275 changes to a cyan color and the digits change to black color but revert to black field with cyan digits, once the knob is no longer rotated.
7. Rotate GI 275 knob and verify the barometric pressure and pressure altitude values incrementally change at the same rate and values match on both the GI 275 and G3X PFD.
- Verify the “Baro” field on the G3X PFD changes to a cyan color and the digits change to black color but revert to black field with cyan digits, once the knob is no longer rotated.

### 8.19 GAP 26 AOA Probe Checks

The following inspection points should be checked after the re-installation of the GAP 26 is complete:

#### 8.19.1 AOA Probe Heater Check



**WARNING**

*When checking the operation of the GAP 26 heater, do not touch the probe.*

1. Verify the proper operation of the AOA probe heater.
  - Apply power to the aircraft
  - Move the AOA heater switch to the ON position.
  - Check the temperature of the probe heater by placing hand above the probe to feel radiant heat or use a temperature probe to verify the elevated temperature of the probe.
  - Move the AOA heater switch to the OFF position.
  - Remove power from the aircraft.

#### 8.19.2 AOA Probe Leak Check



**NOTE**

*Although 14 CFR Part 91 does not require a leak test, the AOA system leak test is a requirement for this STC.*

Leak testing must be performed to provide assurance that any leakage is within an acceptable range and that the system does not experience inconsistent performance or AOA calibration issues. Perform the AOA system leak test by following the steps below:

- Inspect pitot pressure port, AOA pressure port, and drain holes to ensure that all are undamaged and clear of debris.
- Ensure all mounting points for the GAP 26 and replacement inspection panel are secure and there are no visible signs of damage such as cracks around or extending from mounting holes.
- To prevent burns to the body or damage to test equipment disable the heater functionality by opening the circuit breaker prior to performing the leak test.
- If a pitot-static tester is used to perform this test, the required airspeed input is 150 knots.
- Perform the leak test on the pneumatic system with the probe installed on aircraft and with the drain holes fully sealed.
- Apply 150 knots pressure to the system and measure the pressure loss over one minute. A leak rate of 10 knots/min or less is allowable and still maintains proper functionality.



**NOTE**

*Both pressure chambers on the GAP 26 probe have drain holes that when open during normal operation would constitute a designed-in leak that is several times higher than 250 knots/min but does not add significant error.*

- After the leak test is completed, make sure all pressure ports and drain holes on the GAP 26 are open and clear of debris.



**WARNING**

*Failure to make sure the pressure ports and drain holes on the GAP 26 are open and clear of debris could result in equipment damage or a decrease in safety margins.*

### 8.20 Wig-Wag Landing/Taxi Light Check (if configured)

1. Apply power to the aircraft.
2. Locate the Landing and Taxi Light switches and turn both to Flash.
  - Verify the landing and taxi light alternately flash.
3. Turn both “Switch (On)” switches to on and verify they are on continuously.
4. Remove power from the aircraft

### 8.21 CO Detector Display Check (if configured)

1. Apply power to the aircraft with the GDUs in normal mode.
2. On the GDU, navigate to the “Main Menu”,
3. Select “Setup”
4. Select “Data Bar”, on “Data Fields” select “Change”.
5. Touch the magenta pilot-configurable data bar field and select “Carbon Monoxide (ppm)” on the “Data Bar Setup” page to display CO level on the data bar.
  - Verify a CO readout on the data bar field is between 0 to 9 PPM.
6. Remove power from the aircraft

### 8.22 Weight and Balance (W&B) Update (as required)



#### CAUTION

*It is the installer’s responsibility to verify the accuracy of the data/values entered and the resulting envelope graph depicted on the weight and balance configuration page.*



#### NOTE

*The Pilot Operation Handbook (POH) for the aircraft being configured is required to configure the weight and balance page.*



#### NOTE

*Refer to the G3X Touch Installation Manual for information on configuring the Weight & Balance Page.*

The following procedure must be performed when a weight and balance change is made to the aircraft. This ensures the accuracy of the weight and balance page on the G3X system.

1. Apply power to the aircraft with the GDUs in normal mode.
2. On the GDU, Press the **MENU** Key twice to display the Main Menu.
3. Touch the **Weight & Balance** Button. The **Weight & Balance** Page is displayed.
4. From the **Weight & Balance** page, press the **MENU** Key.
5. Touch the **Empty Aircraft** Button.
6. On the ‘**Empty All Stations?**’ pop-up screen, touch the **Yes** Button to empty the aircraft Weight & Balance page data.
7. On the **Weight & Balance** page, verify the **Weight** and **CG** value match with those listed in the aircraft manufacturer Pilot Operation Handbook (POH) and the associated aircraft weight and balance sheet.

*An ‘Out Of Range’ red message may be displayed due to all aircraft Stations being cleared on previous steps.*

8. If the **Weight** and **CG** value listed on *step 7* are different than those on the aircraft manufacturer Pilot Operation Handbook (POH) and the associated aircraft weight and balance sheet, follow the applicable procedure on the G3X Touch Installation Manual to update the weight and balance information.

### 8.23 EMI / RFI Check

An EMC check must be conducted once the G3X Touch system is installed and all interfaces to external equipment are verified to be working correctly. The EMC check verifies that the G3X system is not producing unacceptable interference in other avionics systems and other avionics systems are not producing unacceptable interference in the G3X system. Table 8-4 below should be used to collect data for this check.

1. Enter equipment installed in the aircraft into the Source row and Victim column of the form.
2. Apply power to all avionics systems except for the components that are part of the G3X system.
3. Verify all existing avionics systems are functioning properly.
4. Apply power to the G3X system.
5. Remove power from all other avionics systems.



#### NOTE

*Wait for the current system start up sequence to finish before applying power to the next system.*

6. Apply power and/or operate the systems listed on the fillable form on Table 8-4, one system at a time. Make sure to pull/push circuit breakers or turn on/off large loads, e.g. heaters, cycling flaps (if electrical) etc.
7. Verify the G3X system functions properly and no related messages are displayed.
8. Verify each radio is functioning properly by completing the following:
  - a. For each VHF COM radio, monitor one local frequency, one remote frequency, and one unused frequency.
  - b. Verify no unintended squelch breaks or audio tones interfere with communications.
  - c. For each VHF NAV radio, monitor one local frequency, one remote frequency, and one unused frequency.
  - d. Verify there are no guidance errors.
  - e. Verify no audio tones interfere with the station ID.
  - f. For each GPS Navigator, enter a simple flight plan and display as appropriate. i.e. Navigator Display, PFD, CDI etc., if installed.
  - g. Verify there are no guidance errors.
9. If an EI FT-60 or an EI FT-90 fuel flow sensor is installed, verify the fuel flow indication is accurate and the indication does not fluctuate or invalidate the display.
  - a. Transmit various modulating tones on each COM radio (e.g. Whistling).
  - b. See section the *G3X Touch EFIS Part 23 AML STC Installation Manual (190-02472-01)* for details if the fuel flow indication fluctuates.



#### NOTE

EMI check of the fuel flow must be performed with the engine running.

10. Verify all other avionic systems are functioning properly.

**Table 8-4 – EMI Victim/Source Matrix**

	GDU #1	GDU #2 (If installed)	GMU 11 (Mag. Heading)	GAD 29B/29D (If installed)	GSU 25D (PIT/ROLL)	GDL 5XR (if installed)	GEA24(B) (if installed)	GTP 59 (OAT indication)	Magnetic compass	Navigation Radio(s)	Communication Radio(s)	Fuel Valve	Pitot Heat	Pulse Light	Generator	Pos Lt	Anti-Collision Lt	Landing Lights	Gov RPM Incr / Decr	Hydraulic System	Radar Altimeter	TAS/TCAS	Transponder	Audio Panel	Autopilot / SAS	GAP 26 Heater	GAD 27 Light Flash
<b>SOURCE</b>	GDU #1																										
	GDU #2 (If installed)																										
	GMU 11 (Mag. heading)																										
	GAD 29B/29D (If installed)																										
	GSU 25D (PIT/ROLL)																										
	GDL 5XR (if installed)																										
	GEA 24(B) (if installed)																										
	GTP 59 (OAT Indication)																										
	Magnetic Compass																										
	Navigation Radio(s)																										
	Communication Radio(s)																										
	Fuel Valve																										
	Pitot Heat																										
	Pulse Light																										
	Generator																										
	Pos Lt																										
	Anti-Collision Lt																										
	Landing Lights																										
	Gov RPM Incr / Decr																										
	Hyd System																										
	Radar Altimeter																										
	TAS/TCAS																										
	Transponder																										
	Audio Panel																										
	Autopilot / SAS																										
	GAP 26 Heater																										
	GAD 27 Light Flash																										

## **APPENDIX A INSTALLATION SPECIFIC INFORMATION**

A copy of this appendix must be used to record information for a specific installation of the G3X Touch EFIS Part 23 AML STC system. The completed copy must be kept with the aircraft permanent records. This appendix includes the following information:

### **A.1 Maintenance Records**

This Post-Installation Configuration Log should be completed during the initial installation, with any software modifications post initial installation, and maintained with the aircraft permanent records.

- G3X software version used to perform software updates.
- Record part and serial numbers of all LRU's at installation.
- Record Mod Status of all LRU's at installation.
- Record part and serial numbers of any LRU which was replaced.
- Record any database updates which were performed during maintenance.
- Any other applicable information related to the maintenance work performed on the aircraft.
- Capture configuration data and save on an SD card (Refer to Appendix A.4).

Table A-1 – G3X Post-Installation Log

Post-Installation Configuration Log					
Date:		Aircraft Model:		Aircraft Make:	
Aircraft Registration #:		Aircraft Serial #:		Engine:	
Original Software Version:			New Software Version (if applicable):		
Unit/Option	Installed/Enabled? (check if installed or configured)	LRU Part Number	LRU Serial Number	Mod Status	
GDU 460					
GDU 470					
GMU 11					
GSU 25D					
GTP 59					
GAD 29B/29D					
GAD 27					
GEA 24(B)					
GDL 5XR					
GTR 20					
GTR 200B					
GMA 245R					
GAP 26					

## A.2 Equipment Locations

Appendix B contains a documentation sheet for recording G3X Touch EFIS LRU's included in the installation and its location on the aircraft. The document will be completed during the initial installation and maintained with the aircraft records.

**Table A-2 – G3X Equipment Locations**

Date:	Aircraft Make/Model:	Aircraft Reg #/Serial #:
LRU	Station C.G	Description of Location
GDU 460	in.	
GDU 470	in.	
GMU 11	in.	
GSU 25D	in.	
GTP 59	in.	
GAD 29B/29D	in.	
GAD 27	in.	
GEA 24(B)	in.	
GDL 5XR	in.	
GTR 20	in.	
GTR 200B	in.	
GMA 245R	in.	
GAP 26	in.	

## A.3 Wire Routing

Figure A-1 is a generic aircraft drawing to be used for documenting the wire routing for the installation of the G3X Touch EFIS LRUs. The drawing will be completed during the initial installation and maintained with the aircraft records.

Record equipment locations and sketch the approximate location of wire routing, pneumatic line routing, and location of pneumatic drain (if installed) on Figure A-1 below as applicable.

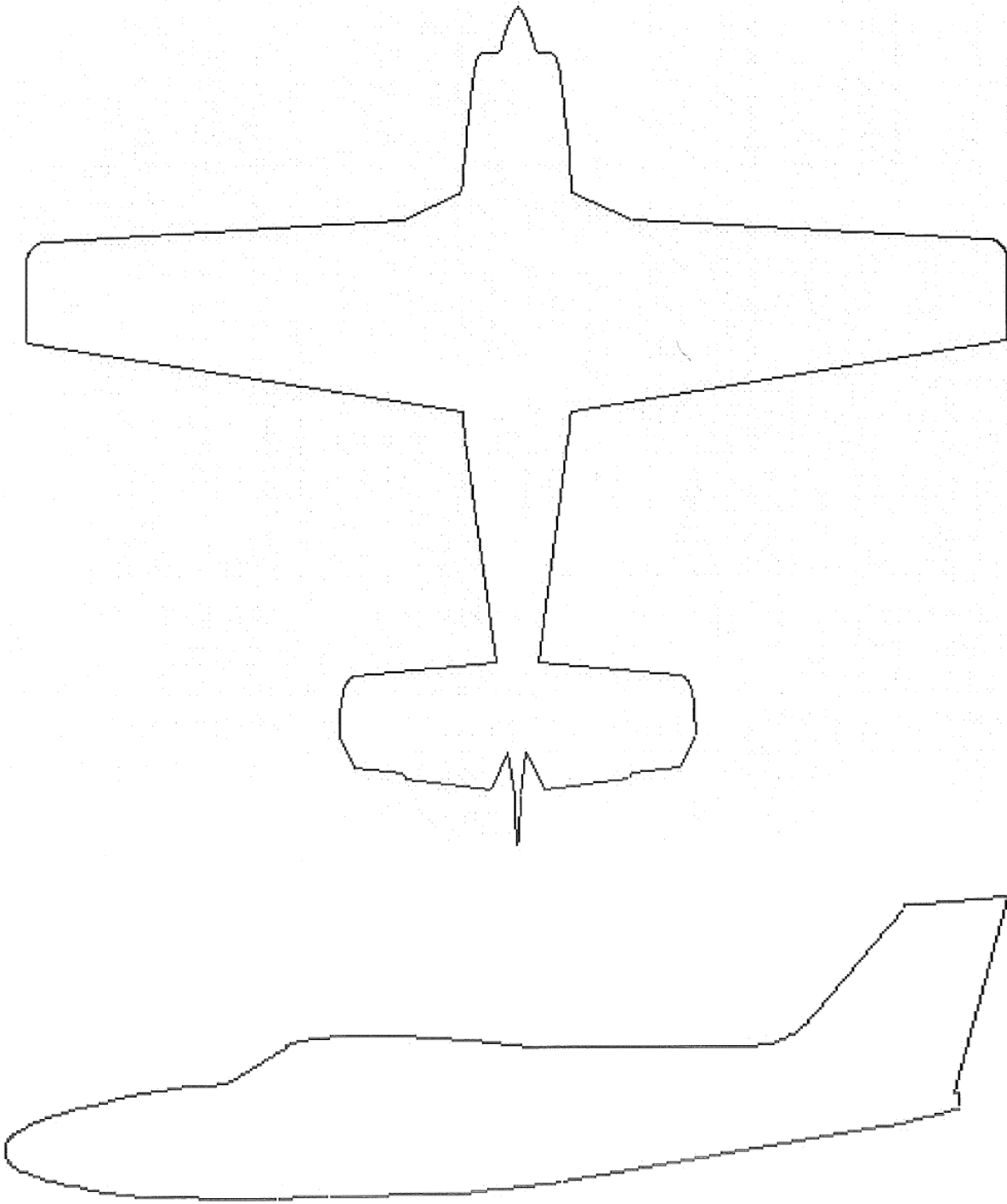

**Figure A-1– Generic Aircraft Figure**



### A.4 Configuration File

The “Config File” page is used to enable uploading and downloading of the G3X System configuration to an SD card. The configuration is written to the loader card in a format which can be uploaded to the system.



**NOTE**

*An SD card must be in the display’s SD card slot for the “Config Files” page to be shown on the Configuration Mode page.*

**To export the configuration:**

1. In configuration mode, navigate to the “Config Files” Page.
2. Press the MENU button.
3. Use the Touch Panel or a Move Selector Knob to select Export System Configuration



4. Message below will appear on the screen, select “Yes” when prompted.



5. The data will be saved on the SD card as a “config.gcb” file in a “config” folder within a “Garmin” folder.



**NOTE**

*The “config.gcb” file can be renamed by the user and it will still be compatible with the G3X system provided the .gcb file extension isn’t changed.*



**NOTE**

*If restoring data to the system from a backup, all previously saved data (including calibration data) will be loaded. If saved configuration data is loaded into a different G3X Touch system, the aircraft specific calibration data will not be overwritten.*

**To import the configuration:**

1. Insert in the display slot an SD card with the “config.gcb” configuration file placed in a folder named “config” within the “Garmin” folder on the SD card.
2. In configuration mode, navigate to the “Config Files” page.

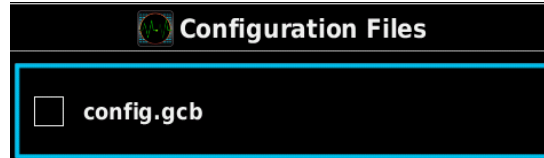

3. Use the Touch Panel or a Move Selector Knob to select the "config.gcb" file.
4. Message similar to one below will appear. Select "Yes" when prompted.

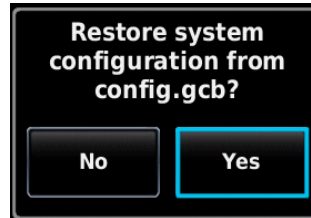

5. When configuration download is complete, a check mark will appear in box next to the "config.gcb" file.

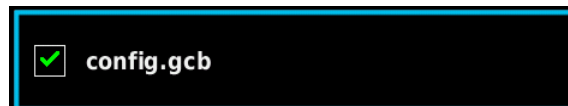

## APPENDIX B EXTERNAL INTERFACE CONFIGURATION

### B.1 GPS/VHF Nav Interfaces

The GPS position sources listed in Table B-1 are compatible with the G3X Touch. Reference Section 3.2.2 for entering configuration and changing data on G3X units.



#### NOTE

*Make configuration changes only as described in this section, changing other configuration settings is not recommended and may significantly alter the unit's operation. Garmin recommends recording all existing configuration settings (before making any changes) for reference.*

**Table B-1 – Compatible Equipment – GPS/VHF Nav Interfaces**

MFR	Model	Data Format	G3X Configuration Setting	Interfacing Equipment Configuration Setting
Garmin	<b>GNS 4XX(W)/5XX(W) Series</b>  Main Software v3.30 or later is required.	ARINC 429	<b><u>ARINC 429 Configuration Page:</u></b> <b>429 Output 1:</b> "EFIS /Airdata Format 1" and "Nav 1" <b>429 Input 1:</b> "Garmin GPS" and "Nav 1" <b>429 Input 2:</b> "Garmin VOR/ILS" and "Nav 1" (GNS 430(W)/530(W))  <i><u>For dual GNS configure #1 GNS as above and #2 GNS as below:</u></i> <b>429 Output 2:</b> "EFIS /Airdata Format 1" and "Nav 2" <b>429 Input 3:</b> "Garmin GPS" and "Nav 2" for GNS #2 (If Applicable) <b>429 Input 4:</b> "Garmin VOR/ILS" and "Nav 2" for GNS #2 (GNS 430(W)/530(W))	<b><u>GNS 4XX(W)/5XX(W) Main ARINC Config Page:</u></b> <b>IN 1 Speed:</b> "LOW" <b>IN 1 Data:</b> "EFIS/Air Data" <b>OUT Speed:</b> "LOW" <b>OUT Data:</b> "GAMA 429" <b>SDI:</b> "LNAV 1" <b>VNAV:</b> "Enable Labels" (WAAS Units Only)  <i><u>When interfaced with Non-Garmin autopilot:</u></i> <b>IN 2 Speed:</b> "LOW" (2) <b>IN 2 Data:</b> "Garmin GAD 42" (2)  <i><u>For dual GNS configure as above and below:</u></i> <b>SDI:</b> "LNAV 2" on #2 GNS ( <i>dual GNS ONLY</i> ) <b>VNAV:</b> "Enable Labels" on #2 GNS (WAAS Units Only)

MFR	Model	Data Format	G3X Configuration Setting	Interfacing Equipment Configuration Setting
		RS-232	<p><b><u>RS-232 Configuration Page</u></b>  <b>Serial Port 'x':</b> "MapMX" (WAAS Unit) or "Aviation In" (Non-WAAS unit)  <b>Serial Port 'x'</b> (Connex bus): "Garmin Instrument Data" (GNS 4XXW/5XXW Only)</p> <p><i>For dual GNS, configure #1 GNS as above and #2 GNS as below:</i></p> <p><b><u>RS-232 Configuration Page</u></b>  <b>Serial Port 'x':</b> "MapMX" (WAAS Unit) or "Aviation In" (Non-WAAS unit) (PFD or MFD)</p> <p><b>NOTE:</b> "x" = Connected Port #            (GNS #1 must be connected to a lower number port than GNS #2. In dual GDU installations GNS, #2 may be connected to any port on the MFD))</p>	<p><b><u>RS-232 Configuration Page</u></b>  <b>CHNL 1 Input:</b> "OFF"  <b>CHNL 1 Output:</b> "MapMX" (WAAS units only) or "Aviation" (Non-WAAS unit)  <b>CHNL 2 Input/Output:</b> "Connex" (When Connex is used)</p>
		Misc.		<p><b><u>Main CDI/OBS Config Page (GNS 430(W)/530(W))</u></b>            Press Menu and select "Ignore SEL CRS for VLOC" Option  <b>Note:</b> Menu will display "Allow SEL Course for VLOC" when set correctly.</p>
				<p><b><u>VOR/ILS ARINC 429 Config Mode Page (GNS 430(W)/530(W))</u></b>  <b>RX and TX Speed:</b> "LOW"  <b>SDI:</b> "VOR/ILS 1" ("VOR/ILS 2" for GNS 2)</p>
	<p><b>GNS 480</b>             Software v2.3 or later is required.</p>	ARINC 429	<p><b><u>ARINC 429 Configuration Page:</u></b>  <b>429 Output 1:</b> "EFIS /Airdata Format 1" and "Nav 1"  <b>429 Input 1:</b> "Garmin GPS" and "Nav 1"  <b>429 Input 2:</b> "Garmin VOR/ILS" and "Nav 1"</p>	<p><b><u>GNS 480 Main ARINC Setup Page:</u></b>  <b>IN 2SEL:</b> "EFIS"  <b>IN 2 Speed:</b> "LOW"  <b>IN 2 SDI:</b> "SYS1"  <b>OUT 1SEL:</b> "GAMA 429"  <b>OUT 1 Speed:</b> "LOW"  <b>OUT 1 SDI:</b> "SYS1"  <b>OUT 2 SEL:</b> "VOR/ILS"  <b>OUT 2 Speed:</b> "LOW"  <b>OUT 2 SDI:</b> "SYS1"</p>
		RS-232	<p><b><u>RS-232 Configuration Page</u></b>  <b>Serial Port 'x':</b> "MapMX"</p>	<p><b><u>GNS 480 Serial Setup Page</u></b>  <b>CHNL 1 Output:</b> "MapMX"</p>

MFR	Model	Data Format	G3X Configuration Setting	Interfacing Equipment Configuration Setting
			NOTE: "x" = Connected Port #	
		Misc.		<b>Resolver Interface Page</b> Resolver: "Not Installed"
				<b>Miscellaneous Setup Page</b> CDI Select: "USE"
	<b>GTN 6XX/ 7XX</b> Software v6.71 or later is required  <b>GTN 6XX/ 7XX Xi</b> Software v20.23 or later is required	ARINC 429	<b>ARINC 429 Configuration Page:</b> <b>429 Output 1:</b> "EFIS /Airdata Format 1" and "Nav 1" <b>429 Input 1:</b> "Garmin GPS" and "Nav 1" <b>429 Input 2:</b> "Garmin VOR/ILS" and "Nav 1"  <i>For dual GTN configure as above (GTN 1) and below (GTN 2):</i> <b>429 Output 2:</b> "EFIS /Airdata Format 1" and "Nav 2" <b>429 Input 3:</b> "Garmin GPS" and "Nav 2" for GTN #2 (If Applicable) <b>429 Input 4:</b> "Garmin VOR/ILS" and "Nav 2" for GTN #2	<b>GTN Main ARINC 429 Config Page:</b> <b>IN 1 Speed:</b> "LOW" <b>IN 1 Data:</b> "GDU Format 2" <b>OUT 1 Speed:</b> "LOW" <b>OUT 1 Data:</b> "Garmin 429" <b>SDI:</b> "LNAV 1"  <i>When interfaced with Non-Garmin autopilot:</i> <b>IN 2 Speed:</b> "LOW" (2) <b>IN 2 Data:</b> "GAD Format 1" (2)  <i>For dual GTN configure as above and below (GTN 2):</i> <b>IN 1 Speed:</b> "LOW" <b>IN 1 Data:</b> "GDU Format 2" <b>OUT 1 Speed:</b> "LOW" <b>OUT 1 Data:</b> "Garmin 429" <b>SDI:</b> "LNAV 2" on #2 GTN (dual GTN ONLY)
		RS-232	<b>RS-232 Configuration Page</b> <b>Serial Port 'x':</b> "MapMX" (PFD) <b>Serial Port 'x':</b> "GTN Connex2" (PFD)  <i>For dual GTN configure as above (GTN 1) and below (GTN 2): (1)</i> <b>Serial Port 'x':</b> "MapMX" (PFD or MFD) for GTN 2  NOTE: "x" = Connected Port # (GTN 1 must be connected to a lower number port than GTN 2. In dual GDU installations GTN, #2 may be connected to any port on the MFD)	<b>GTN RS-232 Configuration Page: On Both GTNs</b> <b>CHNL x Input:</b> "MapMX Format 2" <b>CHNL x Output:</b> "MapMX Format 2" <b>CHNL x Input/Output:</b> "Connex2 Format 2" (When Connex2 is used, #1 GTN Only)  NOTE: "x" = Connected Port
		Misc.		<b>Main Indicator (Analog) Config Page:</b> Selected Course for VLOC: "Ignored"
				<b>VOR/LOC/GS Config Page:</b> Nav Radio: "Enabled"

MFR	Model	Data Format	G3X Configuration Setting	Interfacing Equipment Configuration Setting
				<b>ARINC 429 Config:</b> <b>TX Speed:</b> "LOW" <b>SDI:</b> "VOR/ILS 1" ("VOR/ILS 2" for GTN 2)

**Notes:**

- (1) *In installations with dual GTNs, GTN 1 must be connected to a lower number RS-232 port than GTN 2. In dual GDU installations GTN, #2 may be connected to any port on the MFD)*
- (2) *Only used when a Non-Garmin autopilot is interfaced, reference applicable interconnect diagrams in the G3X Touch EFIS AML STC Installation Manual (190-02472-01).*

## B.2 GPS NAV Interface

The GPS Nav position source listed in Table B-2 is compatible with the G3X Touch. Reference Section 3.2.2 for entering configuration and changing data on G3X units

**Table B-2 – Compatible Equipment – GPS NAV**

MFR	Model	Data Format	G3X Configuration Setting	Interfacing Equipment Configuration Setting
Garmin	<b>GNC 300XL/GPS 155XL</b>	ARINC 429	<b><u>ARINC 429 Configuration Page:</u></b> <b>429 Output 1:</b> "EFIS /Airdata Format 1" and "Nav 1" <b>429 Input 1:</b> "Garmin GPS" and "Nav 1"	<b><u>GNC 300XL/GPS 155XL ARINC 429 Config Page:</u></b> <b>IN:</b> "Course Heading" <b>OUT:</b> "King EFS 40/50"
		RS-232	<b><u>RS-232 Configuration Page:</u></b> <b>Serial Port 'x':</b> "Aviation In"  <i>NOTE: "x" = Connected Port #</i>	<b><u>GNC 300XL/GPS 155XL I/O CHANNEL 1 Config Page:</u></b> <b>IN:</b> "OFF" <b>OUT:</b> "Aviation"
	<b>GPS 175</b>	ARINC 429	<b><u>ARINC 429 Configuration Page:</u></b> <b>429 Output 1:</b> "EFIS /Airdata Format 1" and "Nav 1" <b>429 Input 1:</b> "Garmin GPS" and "Nav 1"	<b><u>GPS 175 ARINC 429 Config Page:</u></b> <b>IN 1:</b> "GDU Format 1", Low Speed <b>OUT 1:</b> "GAMA FORMAT 1", Low Speed <b>SDI:</b> "LNAV 1"
		RS-232	<b><u>RS-232 Configuration Page:</u></b> <b>Serial Port 'x':</b> "MAPMX" <b>Serial Port 'x' (Connex):</b> "CONNEX 57600 BAUD"  <i>NOTE: "x" = Connected Port #</i>	<b><u>GPS 175 RS-232 CHNL 1 Config Page:</u></b> <b>IN &amp; OUT:</b> "MAPMX FORMAT 1"  <b><u>GPS 175 RS-232 CHNL 2 Config Page:</u></b> <b>IN &amp; OUT:</b> "CONNEX 57600"
		Misc.		<b><u>GPS 175 Main Indicator (Analog) Page:</u></b> <b>Selected Course:</b> "Allowed"
	<b>GNC 355(A)</b>	ARINC 429	<b><u>ARINC 429 Configuration Page:</u></b> <b>429 Output 1:</b> "EFIS /Airdata Format 1" and "Nav 1" <b>429 Input 1:</b> "Garmin GPS" and "Nav 1"	<b><u>GNC 355 ARINC 429 Config Page:</u></b> <b>IN 1:</b> "GDU Format 1", Low Speed <b>OUT 1:</b> "GAMA FORMAT 1", Low Speed <b>SDI:</b> "LNAV 1"
		RS-232	<b><u>RS-232 Configuration Page:</u></b> <b>Serial Port 'x':</b> "MAPMX" <b>Serial Port 'x' (Connex):</b> "CONNEX 57600 BAUD"  <i>NOTE: "x" = Connected Port #</i>	<b><u>GNC 355 RS-232 CHNL 1 Config Page:</u></b> <b>IN &amp; OUT:</b> "MAPMX FORMAT 2"  <b><u>GNC 355 RS-232 CHNL 2 Config Page:</u></b> <b>IN &amp; OUT:</b> "CONNEX 57600"
		Misc.		<b><u>GNC 355 Main Indicator (Analog) Page:</u></b> <b>Selected Course:</b> "Allowed"

MFR	Model	Data Format	G3X Configuration Setting	Interfacing Equipment Configuration Setting
	GNX 375	ARINC 429	<b><u>ARINC 429 Configuration Page:</u></b> <b>429 Output 1:</b> “EFIS /Airdata Format 1” and “Nav 1” <b>429 Input 1:</b> “Garmin GPS” and “Nav 1”	<b><u>GNX 375 ARINC 429 Config Page:</u></b> <b>IN 1:</b> “EFIS/AIR DATA”, Low Speed <b>OUT 1:</b> “GAMA FORMAT 1”, Low Speed <b>SDI:</b> “LNAV 1”
		RS-232	<b><u>RS-232 Configuration Page:</u></b> <b>Serial Port ‘x’:</b> “MAPMX” <b>Serial Port ‘x’ (Connex):</b> “CONNEXT 57600 BAUD” (2)  <i>NOTE: “x” = Connected Port #</i>  <i>NOTE: No GSU configuration is required</i>	<b><u>GNX 375 RS-232 CHNL 1 Config Page</u></b> (Connected to GDU) <sub>2</sub> <b>IN &amp; OUT:</b> “MAPMX FORMAT 1”  <b><u>GNX 375 RS-232 CHNL ‘x’ Config Page</u></b> (Connected to GDU for Connex & ADS-B) <sub>2</sub> <b>IN &amp; OUT:</b> “CONNEXT 57600”  <b><u>GNX 375 RS-232 CHNL ‘x’ Config Page</u></b> (Connected to GSU 25D) <sub>2</sub> <b>IN &amp; OUT:</b> “TRANSPONDER FRMT 1”
		Misc.	<b><u>Transponder Configuration Page:</u></b> <b>Transponder Type:</b> “GNX 375” (1) <b>On-screen Controls:</b> “Show” (if desired) or “Hide”	<b><u>GNX 375 Main Indicator (Analog) Page:</u></b> <b>Selected Course:</b> “Allowed”

**Notes:**

- (1) Set type on transponder configuration page of the GDU in configuration mode if remote control of Transponder on G3X GDU is desired.
- (2) Only one ADS-B Source maybe configured at a time.



### B.3 VHF NAV/COM Interface

The navigation receivers listed in Table B-3 are compatible with the G3X Touch system. These receivers transmit data to the G3X Touch system digitally.

**Table B-3 – Compatible Equipment – VHF NAV/COM**

MFR	Model	Data Format	G3X Configuration Setting	Interfacing Equipment Configuration Setting
Garmin	<b>GNC 215</b>	RS-232	<b>RS-232 Configuration Page:</b> <b>Serial Port 'x':</b> "Garmin VHF Nav/Comm" <i>NOTE: "x" = Connected Port #</i>	<b>RS-232 Configuration Page:</b> Format: "NMEA 1"
	<b>GNC 255</b>  <i>GNC software v2.21 or later is required to support remote Nav tuning from G3X.</i>	RS-232	<b>RS-232 Configuration Page:</b> <b>Serial Port 'x':</b> "Garmin VHF Nav/Comm" <i>NOTE: "x" = Connected Port #</i>	<b>Nav Configuration Page:</b> <b>CDI Indicator Type:</b> "Serial" <b>SYS Configuration Page:</b> <b>Serial Port IO Mode:</b> "NMEA"
	<b>SL 30</b>	RS-232	<b>RS-232 Configuration Page:</b> <b>Serial Port 'x':</b> "Garmin VHF Nav/Comm" <i>NOTE: "x" = Connected Port #</i>	<b>Nav Setup Pages:</b> <b>Attitude Config Page:</b> <b>Indicator Head Type:</b> "Serial"
	<b>SL 40</b>	RS-232	<b>RS-232 Configuration Page:</b> <b>Serial Port 'x':</b> "Garmin VHF Comm" <i>NOTE: "x" = Connected Port #</i>	N/A
	<b>GTR 205</b>	RS-232	<b>RS-232 Configuration Page:</b> <b>Serial Port 'x':</b> "Garmin VHF Comm" <i>NOTE: "x" = Connected Port #</i>	<b>RS-232 Configuration Page:</b> Format: "NMEA 1"
	<b>GTR 225</b>	RS-232	<b>RS-232 Configuration Page:</b> <b>Serial Port 'x':</b> "Garmin VHF Comm" <i>NOTE: "x" = Connected Port #</i>	<b>SYS Configuration Page:</b> <b>Serial Port IO Mode:</b> "NMEA"
	<b>GTR 20</b>	CAN	<i>Reference <a href="#">G3X Touch EFIS Part 23 AML STC Installation Manual</a> for configuration information</i>	None
	<b>GTR 200B</b>	CAN	<i>Reference <a href="#">G3X Touch EFIS Part 23 AML STC Installation Manual</a> for configuration information</i>	<i>Reference <a href="#">G3X Touch EFIS Part 23 AML STC Installation Manual</a> for configuration information</i>

## B.4 Traffic and Weather Source

Table B-4 – Compatible Traffic and Weather Sources

MFR	Model	Data Format	G3X Configuration Setting	Interfacing Equipment Configuration Setting
Garmin	GTX 33(ES) GTX 330(ES) GTX 32 GTX 327 GTX 328	RS-232	<p><b>Transponder Configuration Page:</b>  <b>Transponder Type:</b> “GTX 32” or “GTX 33” or “GTX 33ES” or “GTX 327” or “GTX 328” or “GTX 330” or “GTX 330ES” as appropriate (1)</p> <p>(3)  <i>Note: No GSU configuration is required</i></p>	<p><b>GTX 330(ES)/327/328 RS-232 Config Mode Page:</b>  <b>RS-232 Input:</b> “Remote”  <b>RS-232 Output:</b> “Remote+TIS”  <i>Note: No configuration is required for GTX32/33(ES)</i></p> <p><b>GTX 328/330 Squat Switch Config Mode Page:</b>  <b>Squat Switch:</b> “NO”</p>
	GTX 325 GTX 335(D) GTX 335(D)R	RS-232	<p><b>Transponder Configuration Page:</b>  <b>Transponder Type:</b> “GTX 325” or “GTX 335” or “GTX 335D” or “GTX 335R” or “GTX 335DR” as appropriate (1)</p> <p><b>GTX 335(D)R Connected to Garmin Navigator for Position Source for ADS-B Out</b>  <b>Transponder Configuration Page:</b>  <b>RS-232 Port ‘x’:</b> ‘ADS-B+ GPS’</p> <p>(3)  <i>NOTE: No GSU configuration is required</i>  <i>NOTE: “x” = Connected Port #</i></p>	<p><b>GTX 325/335(D) RS-232 Set Up Page:</b>  <b>RS-232 CH 1</b> (Connected to GSU 25D: “XPDR FMT 1”</p> <p><i>For ADS-B</i>  <b>GTX 335(D) RS-232 CH</b> (Connected to Garmin Navigator) Input: “ADS-B+”</p> <p><b>GTN/GNS RS-232 Configuration Page:</b>  <b>RS-232 CH</b> (Connected to GTX) Output: “ADS-B+ Format 1”</p>
	GTX 345(D)  <i>GTX software v2.60 or later is required.</i>	RS-232	<p><b>Transponder Configuration Page:</b>  <b>Transponder Type:</b> “GTX 345” or “GTX 345D” as appropriate (1)</p> <p><b>On-screen Controls:</b> “Show” (if desired) or “Hide”</p> <p><b>RS-232 Configuration Page:</b>  <b>RS-232 Port ‘x’:</b> ‘Connnext 115200 Baud’ (GDU port connected to GTX) (2)  - For Traffic/Weather (if no other source is connected)</p> <p>The GTX 345(D) also provides FIS-B weather data with this interface.</p> <p><i>NOTE: No GSU configuration is required</i>  <i>NOTE: “x” = Connected Port #</i></p>	<p><b>GTX RS-232 Set Up Page:</b>  <b>RS-232 CH 1</b> (Connected to GSU 25D)  <b>Input/Output Format:</b> “XPDR FMT 1”  <b>RS-232 CH ‘x’</b> (Connected to GDU):  <b>Input/output:</b> “Connnext FMT 4”</p> <p><i>For ADS-B</i>  <b>GTX RS-232 CH</b> (Connected to Garmin Navigator) Input: “ADS-B+”</p> <p><b>GNS RS-232 Configuration Page:</b>  <b>RS-232 CH</b> (Connected to GTX) Output: “ADS-B+ Format 1”  <i>NOTE: “x” = Connected Port #</i></p>

MFR	Model	Data Format	G3X Configuration Setting	Interfacing Equipment Configuration Setting
	<b>GTX 345(D)R</b>  <i>GTX software v2.60 or later is required.</i>	RS-232 HSDB (w/ GTN or GTS)	<p><b>Transponder Configuration Page:</b>  <b>Transponder Type:</b> "GTX 345R" or "GTX 345DR" as appropriate (1)</p> <p><b>RS-232 Port 'x':</b> 'Connex FMT 4" (GTX port connected to GDU)</p> <p><b>RS-232 Configuration Page:</b>  <b>RS-232 Port 'x':</b> 'Connex 115200 Baud" (GDU port connected to GTX) (2)            For Traffic/Weather (if no other source is connected)</p> <p><u>ADS-B/TIS-B</u>  <u>GTX 345(D)R Connected to Garmin Navigator for Position Source for ADS-B Out (2)</u>  <b>Transponder Configuration Page:</b>  <b>HSDB Devices:</b> Enable "GTN" or "GTS"</p> <p><i>NOTE: No GSU configuration is required</i>  <i>NOTE: "x" = Connected Port #</i></p>	<p><b>GTX Installed with GTN</b>  <b>GTN Interfaced Equipment Page:</b>  <b>ADS-B IN Source Type:</b> "GTX #1"</p> <p><b>GNS RS-232 Configuration Page:</b>  <b>RS-232 CH (Connected to GTX) Output:</b> "ADS-B+ Format 1"</p>
	<b>GTX 345(D)R w/ Non-Garmin Traffic</b>	RS-232 HSDB (w/ GTN)	<p><b>Transponder Configuration Page:</b>  <b>Transponder Type:</b> "None"</p> <p><b>RS-232 Configuration Page:</b>  <b>RS-232 Port 'x':</b> 'Connex 115200 Baud" (GDU port connected to GTX) (2)</p> <p><i>NOTE: "x" = Connected Port #</i></p>	<p><b>GTN Interfaced Equipment Page:</b>  <b>ADS-B IN Source Type:</b> "GTX #1"</p> <p><b>GTX Install Tool Configuration: (5)</b>  <b>RS-232 CH 1 (Connected to GSU 25D) Input/Output Format:</b> "Transponder R FMT 1"  <b>RS-232 CH 'x' (Connected to GDU):</b> Input/output: "Connex FMT 4"</p> <p><i>NOTE: "x" = Connected Port #</i></p>
	<b>GDL 5XR</b>	RS-232	<p><b>RS-232 Configuration Page:</b>  <b>RS-232 Port 'x':</b> 'Connex 57600 Baud" (GDU port connected to GDL) (2)</p> <p><i>NOTE: "x" = Connected Port #</i></p>	N/A
	<b>GTS 8XX</b>  <i>Software V4.10 and later for GTS 8X0, v3.10 and later for GTS 8X5</i>	RS-232 ARINC 429 (if connected to GTX)	<p><b>RS-232 Configuration Page:</b>  <b>RS-232 Port 'x':</b> GTS Instrument Data</p> <p><i>If a remote GTX that supports TIS-A is installed disable as shown below:</i></p> <p><b>Transponder Configuration Page:</b>  <b>TIS-A Traffic Data:</b> "Disable"</p>	<p><b>GTS 8XX Traffic Display Destination Page:</b>  <b>Enhanced COM Port:</b> "RS-232 Port x" (GTS port connected to GDU)</p> <p><b>GTS 8XX Configuration Page:</b>  <b>ADS-B Receiver:</b> "On"  <b>Allow ADS-B in Standby:</b> Enabled</p> <p><i>If GTX 335(D)(R) is installed:</i></p>

MFR	Model	Data Format	G3X Configuration Setting	Interfacing Equipment Configuration Setting
				<p><b><u>GTS 8XX Transponder 1 Communication Page:</u></b>  <b>A429 Primary TX/RX:</b> set to "TX/RX Channel <u>x</u> and Check HIGH SPEED"            (GTS port connected to GTX)</p> <p><b><u>GTS 8XX GPS Position Velocity Page, Barometric Altitude Source, and Magnetic Heading Source:</u></b>  <b>A429 Primary RX:</b> set to "RX Channel <u>x</u> and Check HIGH Speed" (GTS port connected to GTX)</p> <p>NOTE: "<u>x</u>" = Connected Port #</p>

**Notes:**

- (1) Set type on transponder configuration page of the GDU in configuration mode if remote control of Transponder on G3X GDU is desired. If the transponder will be controlled by another device such as a GTN, set Transponder Type to None on the G3X configuration page.
- (2) Only one ADS-B Source maybe configured at a time.
- (3) If a GDL 50R/52R is installed with a GTX 33ES or GTX 335(D)R, ensure UAT and 1090ES are enabled (green indicator). Reference the G3X Touch EFIS Part 23 AML STC Installation Manual (190-02472-01) for detailed configuration information.
- (4) See Table B.2 for GNX 375 configuration information.
- (5) To configure GTX 345(D)R with a non-Garmin traffic system, the GTX 3X5 Installation Tool must be used. Reference the GTX 3X5 TSO Installation Manual 190-01499-02 for guidance. GTX 345(D)R configuration module must be installed.

## B.5 Non-Garmin Autopilot Systems

Non-Garmin autopilots listed in Table B-5 are compatible with the G3X Touch system.

**Table B-5 – Compatible Equipment – Non-Garmin Autopilots**

MFR	Model	Data Format	G3X Configuration Setting	Interfacing Equipment Configuration Information
Century	1C388*	analog	<b><u>Analog Autopilot Configuration Page:</u></b> Autopilot Type: "Century 1C388" GPS Steering: "Enabled" GPSS Scale Factor: "1.000"	
	1C388M*	analog	<b><u>Analog Autopilot Configuration Page:</u></b> Autopilot Type: "Century 1C388M" GPS Steering: "Enabled" GPSS Scale Factor: "1.000"	
	1C388C*	analog	<b><u>Analog Autopilot Configuration Page:</u></b> Autopilot Type: "Century 1C388C" GPS Steering: "Enabled" GPSS Scale Factor: "1.000"	
	1C388MC*	analog	<b><u>Analog Autopilot Configuration Page:</u></b> Autopilot Type: "Century 1C388MC" GPS Steering: "Enabled" GPSS Scale Factor: "1.000"	
	1C388-2*	analog	<b><u>Analog Autopilot Configuration Page:</u></b> Autopilot Type: "Century 1C388-2" GPS Steering: "Enabled" GPSS Scale Factor: "1.000"	
	1C388-3*	analog	<b><u>Analog Autopilot Configuration Page:</u></b> Autopilot Type: "Century 1C388-3" GPS Steering: "Enabled" GPSS Scale Factor: "1.000"	
	2000	analog	<b><u>Analog Autopilot Configuration Page:</u></b> Autopilot Type: "Century 2000" GPS Steering: "Enabled" GPSS Scale Factor: "1.000"	
	21	analog	<b><u>Analog Autopilot Configuration Page:</u></b> Autopilot Type: "Century 21" GPS Steering: "Enabled" GPSS Scale Factor: "1.000"	
	31	analog	<b><u>Analog Autopilot Configuration Page:</u></b> Autopilot Type: "Century 31" GPS Steering: "Enabled" GPSS Scale Factor: "1.000"	

MFR	Model	Data Format	G3X Configuration Setting	Interfacing Equipment Configuration Information
	41	analog	<b><u>Analog Autopilot Configuration Page:</u></b> Autopilot Type: "Century 41" GPS Steering: "Enabled" GPSS Scale Factor: "1.000"	
	IV	analog	<b><u>Analog Autopilot Configuration Page:</u></b> Autopilot Type: "Century IV" GPS Steering: "Enabled" GPSS Scale Factor: "1.000"	
Cessna	300 IFCS 400 IFCS 800 IFCS	analog	<b><u>Analog Autopilot Configuration Page:</u></b> Autopilot Type: "Cessna 300 (AC)", "Cessna 400 (AC)" or "Cessna 800 (AC)" – as applicable. GPS Steering: "Enabled" GPSS Scale Factor: "1.000"	
	300B IFCS 400B IFCS 800B IFCS	analog	<b><u>Analog Autopilot Configuration Page:</u></b> Autopilot Type: "Cessna 300 (DC)", "Cessna 400 (DC)" or "Cessna 800 (DC)" – as applicable. GPS Steering: "Enabled" GPSS Scale Factor: "1.000"	
Honeywell / Bendix King	KAP 100	analog	<b><u>Analog Autopilot Configuration Page:</u></b> Autopilot Type: "Bendix King KAP 100" GPS Steering: "Enabled" GPSS Scale Factor: "1.000"	
	KAP 140	analog	<b><u>Analog Autopilot Configuration Page:</u></b> Autopilot Type: "Bendix King KAP 140" GPS Steering: "Enabled" GPSS Scale Factor: "1.000"	
	KAP 150	analog	<b><u>Analog Autopilot Configuration Page:</u></b> Autopilot Type: "Bendix King KAP 150" GPS Steering: "Enabled" GPSS Scale Factor: "1.000"	
	KAP 200	analog	<b><u>Analog Autopilot Configuration Page:</u></b> Autopilot Type: "Bendix King KAP 200" GPS Steering: "Enabled" GPSS Scale Factor: "1.000"	
	KFC 150	analog	<b><u>Analog Autopilot Configuration Page:</u></b> Autopilot Type: "Bendix King KFC 150" GPS Steering:	

MFR	Model	Data Format	G3X Configuration Setting	Interfacing Equipment Configuration Information
			“Enabled” <b>GPSS Scale Factor:</b> “1.000”	
	KFC 200	analog	<b><u>Analog Autopilot Configuration Page:</u></b> <b>Autopilot Type:</b> “Bendix King KFC 200” <b>GPS Steering:</b> “Enabled” <b>GPSS Scale Factor:</b> “1.000”	
	KFC 225	analog, ARINC 429 GPSS	<b><u>Analog Autopilot Configuration Page:</u></b> <b>Autopilot Type:</b> “Bendix King KFC 225”	
S-TEC	System 20	analog, discrete	<b><u>Analog Autopilot Configuration Page:</u></b> <b>Autopilot Type:</b> “S-Tec System 20” <b>GPS Steering:</b> “Enabled” <b>GPSS Scale Factor:</b> “1.000”	Must be configured to operate with KI-525 (KCS-55) heading system.
	System 30	analog, discrete	<b><u>Analog Autopilot Configuration Page:</u></b> <b>Autopilot Type:</b> “S-Tec System 30” <b>GPS Steering:</b> “Enabled” <b>GPSS Scale Factor:</b> “1.000”	Must be configured to operate with KI-525 (KCS-55) heading system.
	System 40	analog, discrete	<b><u>Analog Autopilot Configuration Page:</u></b> <b>Autopilot Type:</b> “S-Tec System 40” <b>GPS Steering:</b> “Enabled” <b>GPSS Scale Factor:</b> “1.000”	Must be configured to operate with KI-525 (KCS-55) heading system.
	System 50	analog, discrete	<b><u>Analog Autopilot Configuration Page:</u></b> <b>Autopilot Type:</b> “S-Tec System 50” <b>GPS Steering:</b> “Enabled” <b>GPSS Scale Factor:</b> “1.000”	Must be configured to operate with KI-525 (KCS-55) heading system.
	System 55	analog, discrete	<b><u>Analog Autopilot Configuration Page:</u></b> <b>Autopilot Type:</b> “S-Tec System 55” <b>GPS Steering:</b> “Enabled” <b>GPSS Scale Factor:</b> “1.000”	Must be configured to operate with KI-525 (KCS-55) heading system.
	System 55X	analog, discrete, ARINC 429	<b><u>Analog Autopilot Configuration Page:</u></b> <b>Autopilot Type:</b> “S-Tec System 55X”	Must be configured to operate with KI-525 (KCS-55) heading system.
	System 60	analog, discrete	<b><u>Analog Autopilot Configuration Page:</u></b> <b>Autopilot Type:</b> “S-Tec System 60” <b>GPS Steering:</b> “Enabled” <b>GPSS Scale Factor:</b> “1.000”	Must be configured to operate with KI-525 (KCS-55) heading system.
	System 65	Analog discrete	<b><u>Analog Autopilot Configuration Page:</u></b>	Must be configured to operate with KI-525 (KCS-55) heading system.

MFR	Model	Data Format	G3X Configuration Setting	Interfacing Equipment Configuration Information
			<b>Autopilot Type:</b> "S-Tec System 65" <b>GPS Steering:</b> "Enabled" <b>GPSS Scale Factor:</b> "1.000"	
Piper	Autocontrol III/IIIB/IIIC	analog	<b>Analog Autopilot Configuration Page:</b> <b>Autopilot Type:</b> "Piper AutoControl" <b>GPS Steering:</b> "Enabled" <b>GPSS Scale Factor:</b> "1.000"	
	Altimatec III/IIIB-1/IIIC	analog	<b>Analog Autopilot Configuration Page:</b> <b>Autopilot Type:</b> "Piper Altimatec" <b>GPS Steering:</b> "Enabled" <b>GPSS Scale Factor:</b> "1.000"	

### B.6 Audio Panel

The following audio panels interface with the G3X Touch system. For all other audio panels, refer to installation guidance for the selected audio panel for configuration information.

**Table B-6 – Compatible Equipment – Audio Panel**

MFR	Model	Data Format	G3X Configuration Setting	Interfacing Equipment Configuration Setting
Garmin	GMA 342/345	RS-232	<b>RS-232 Configuration Page:</b> <b>Serial Port 'x':</b> "Garmin Instrument Data" <i>NOTE: "x" = Connected Port #</i>	Refer to the GMA 342/345 Installation Manual for guidance.
			<b>Sound Configuration Page:</b> <b>Alert Source:</b> "PFD" <b>Alert Output:</b> "Mono Only"	
	GMA 245R	CAN	<b>Sound Configuration Page:</b> <b>Alert Source:</b> "PFD" <b>Alert Output:</b> "Mono Only"  <i>NOTE: Reference Section 5 for additional configuration information</i>	None



## B.7 EIS Sensors

G3X EIS gauge displays require data captured by approved sensors that are configured in accordance with Table B-7. EIS Sensors that are authorized as Interface Only require a separate installation approval.

**Table B-7 – Compatible EIS Sensors**

Function	Mfg.	Garmin P/N	Description	G3X Sensor Input Configuration	STC Approval
<b>Cylinder Head Temperature</b>	Alcor	494-70008-00	Alcor 86252 (K type probe)	CHT → Type K	Interface Only
	Varies	N/A	K Type Thermocouple	CHT → Type K	Interface Only
	Varies	N/A	J Type Thermocouple	CHT → Type J	Interface Only
<b>Exhaust Gas Temperature</b>	Alcor	494-70001-00	Alcor 86255 (Type K Thermocouple, Clamp)	EGT → Type K	Interface Only
	Varies	N/A	K Type Thermocouple	EGT → Type K	Interface Only
<b>Turbo Inlet Temperature</b>	Alcor	494-70002-00	Alcor 86245 (Type K probe)	Misc. Temp 1 or 2 → Turbine Inlet Temp 1 or 2 (Type K Thermocouple)	Interface Only
	Varies	N/A	K Type Thermocouple	Misc. Temp 1 or 2 → Turbine Inlet Temp 1 or 2 (Type K Thermocouple)	Interface Only
<b>Oil Pressure</b>	Garmin	011-04202-30	150 PSIG Brass	Oil Pressure → Kavlico P4055-5020-4	Interface & Installation
	Garmin	011-05783-30	GPT 150PSIG Stainless Steel	Oil Pressure → Garmin GPT 150G	Interface & Installation
	Textron Aviation	N/A	Beech 102-389017-1	Oil Pressure → Beech 102-389017	Interface Only
	Textron Aviation	N/A	Beech 102-389017-3	Oil Pressure → Beech 102-389017	Interface Only
	UMA	N/A	T1EU150G	Oil Pressure → UMA T1EU150G	Interface Only
	UMA	N/A	T1EU150G-CS	Oil Pressure → UMA T1EU150G	Interface Only
<b>Oil Temp</b>	UMA	494-70009-00	T3B3-2.5G (K Type probe)	Oil Temp → Type K	Interface & Installation
	UMA	N/A	T3B3	Oil Temp → Type K	Interface Only
	UMA	N/A	T3B3A	Oil Temp → Type K	Interface Only
	UMA	N/A	T3B3-2.5	Oil Temp → Type K	Interface Only
	Mil-Spec	N/A	MS28034	Oil Temp → MS28034	Interface Only
	Varies	N/A	K Type Thermocouple	Oil Temp → Type K	Interface Only
<b>Manifold Pressure</b>	Garmin	011-04202-00	30 PSIA Brass	Manifold Pressure → Kavlico P4055-5020-1	Interface & Installation
	Garmin	011-05783-00	GPT 30PSIA Stainless Steel	Manifold Pressure → Garmin GPT 30A	Interface & Installation
	UMA	N/A	T1EU50A	Manifold Pressure → UMA T1EU50A	Interface Only
	UMA	N/A	T1EU50A-CS	Manifold Pressure → UMA T1EU50A	Interface Only
	UMA	N/A	T1EU050A-[ ] [ ]	Manifold Pressure → UMA T1EU50A	Interface Only
<b>Carb Air Temp</b>	UMA	494-70010-00	T3B10-SG (K Type probe)	Misc. Temp 1 or 2 → Carb Temp (Type K Thermocouple)	Interface & Installation
	Mil-Spec	N/A	MS28034	Misc. Temp 1 or 2 → Carb Temp (MS28034)	Interface Only

Function	Mfg.	Garmin P/N	Description	G3X Sensor Input Configuration	STC Approval
	Varies	N/A	K Type Thermocouple (various manufacturers)	Misc. Temp 1 or 2 → Carb Temp (Type K Thermocouple)	Interface Only
<b>Fuel Press</b>	Garmin	011-04202-20	75 PSIG Brass	Fuel Pressure → Kavlico P4055-5020-3 (0-75 PSI)	Interface & Installation
	Garmin	011-05783-20	GPT 75PSIG Stainless Steel	Fuel Pressure → Garmin GPT 75G (0-75 PSI)	Interface & Installation
	Garmin	011-04202-10	15 PSIG Brass	Fuel Pressure → Kavlico P4055-5020-2 (0-15 PSI)	Interface & Installation
	Garmin	011-05783-10	GPT 15PSIG Stainless Steel	Fuel Pressure → Garmin GPT 15G (0-15 PSI)	Interface & Installation
	UMA	N/A	T1EU70G	Fuel Pressure → UMA T1EU70G (0-70 PSI)	Interface Only
	UMA	N/A	T1EU70G-CS	Fuel Pressure → UMA T1EU70G (0-70 PSI)	Interface Only
	UMA	N/A	T1EU35G	Fuel Pressure → UMA T1EU35G (0-35 PSI)	Interface Only
<b>Shunt</b>	Varies	N/A	AA55524 (various mfr)	Shunt 1 or 2 (manual configuration)	Interface Only
	Lamar	N/A	CS3200	Shunt 1 or 2 (manual configuration)	Interface Only
<b>Voltage</b>	Varies	N/A	N/A (sense Bus Voltage)	Volts 1 or 2 (manual configuration)	Interface Only
<b>Fuel Quantity</b>	Resistive float*	N/A	25-620Ω Resistive float interfaced with dual 2.2k Ω resistors to GEA 24 or 24B	Fuel 1 or 2 or 3 or 4 → Voltage*	Interface Only
	Resistive float*	N/A	25-620Ω Resistive float with direct interface to GEA 24B Only	Fuel 1 or 2 or 3 or 4 → Resistive*	Interface Only
	CIES CORP	N/A	CiES CC284022-XXXX-105 (0-5V Analog)	Fuel 1 or 2 or 3 or 4 → Voltage	Interface Only
	CIES CORP	N/A	CiES CC284022-XXXX-101 (Digital)	Fuel 1 or 2 or 3 or 4 → Digital	Interface Only
<b>Fuel Flow &amp; Return FF</b>	Electronics International	494-10001-00	EI FT-60 (Red Cube)	Fuel Flow → EI FT-60	Interface & Installation
	Electronics International	494-10001-01	EI FT-90 (Gold Cube)	Fuel Flow → EI FT-90	Interface & Installation
	Textron Aviation	N/A	102-389012-11	Fuel Flow → Beech 102-389012	Interface Only
	JPI	N/A	JPI 700900-1 (201)	Fuel Flow → Floscan 201 B6	Interface Only
	JPI	N/A	JPI 700900-2 (231)	Fuel Flow → Floscan 231	Interface Only

Function	Mfg.	Garmin P/N	Description	G3X Sensor Input Configuration	STC Approval	
	Floscan	N/A	Floscan 201 B-6	Fuel Flow → Floscan 201 B6	Interface Only	
	Floscan	N/A	Floscan 231	Fuel Flow → Floscan 231	Interface Only	
	Shadin	N/A	Shadin 680501(XX.X) Shadin 680501-1(XX.X)	Fuel Flow → Floscan 201 B6	Interface Only	
<b>RPM</b>	UMA	N/A	UMA T1A9-1 (Slick Mag)	RPM 1 → UMA T1A9 Mag Port (4 or 6-Cylinder)	Interface Only	
	UMA	N/A	UMA T1A9-2 (Bendix Mag)	RPM 1 → UMA T1A9 Mag Port (4 or 6-Cylinder)	Interface Only	
		N/A	Magneto P-lead, 4-Cylinder	RPM → Magneto P-Lead (1.000 pulse/rev)	N/A (No sensor req'd)	
		N/A	Magneto P-lead, 6-Cylinder	RPM → Magneto P-Lead (1.500 pulse/rev)	N/A (No sensor req'd)	
		N/A	Magneto P-lead, 6-Cylinder, 0.64000:1 Prop Gear Ratio	RPM → Magneto P-Lead (2.344 pulse/rev)	N/A (No sensor req'd)	
		N/A	Magneto P-lead, 6-Cylinder, 0.64167:1 Prop Gear Ratio	RPM → Magneto P-Lead (2.337 pulse/rev)	N/A (No sensor req'd)	
		N/A	Magneto P-lead, 6-Cylinder, 0.64200:1 Prop Gear Ratio	RPM → Magneto P-Lead (2.337 pulse/rev)	N/A (No sensor req'd)	
		N/A	Magneto P-lead, 6-Cylinder, 0.66700:1 Prop Gear Ratio	RPM → Magneto P-Lead (2.249 pulse/rev)	N/A (No sensor req'd)	
		N/A	Magneto P-lead, 6-Cylinder, 0.75000:1 Prop Gear Ratio	RPM → Magneto P-Lead (2.000 pulse/rev)	N/A (No sensor req'd)	
		N/A	Dual Magneto P-lead, 4-Cylinder	RPM → Magneto P-Lead (2.000 pulse/rev)	N/A (No sensor req'd)	
		N/A	Dual Magneto P-lead, 6-Cylinder	RPM → Magneto P-Lead (1.500 pulse/rev)	N/A (No sensor req'd)	
		SureFly	N/A	TACH2 0-5V, 4-Cylinder	RPM → Magneto P-Lead (1.000 pulse/rev)	Interface Only
		SureFly	N/A	TACH2 0-5V, 6-Cylinder	RPM → Magneto P-Lead (1.500 pulse/rev)	Interface Only
		SureFly	N/A	TACH2 0-5V, 6-Cylinder, 0.64000:1 Prop Gear Ratio	RPM → Magneto P-Lead (2.344 pulse/rev)	Interface Only
		SureFly	N/A	TACH2 0-5V, 6-Cylinder, 0.64167:1 Prop Gear Ratio	RPM → Magneto P-Lead (2.337 pulse/rev)	Interface Only
		SureFly	N/A	TACH2 0-5V, 6-Cylinder, 0.64200:1 Prop Gear Ratio	RPM → Magneto P-Lead (2.337 pulse/rev)	Interface Only
		SureFly	N/A	TACH2 0-5V, 6-Cylinder, 0.66700:1 Prop Gear Ratio	RPM → Magneto P-Lead (2.249 pulse/rev)	Interface Only
		SureFly	N/A	TACH2 0-5V, 6-Cylinder, 0.75000:1 Prop Gear Ratio	RPM → Magneto P-Lead (2.000 pulse/rev)	Interface Only

*\* Configure 'Voltage' when the GEA 24 or GEA 24B is wired with dual 2.2k $\Omega$  resistors (ref. G3X Touch EFIS Installation Manual for wiring information). Configure 'Resistive' when the GEA 24B is wired without any in-line resistors. Do not configure 'Resistive' for the GEA 24, it must use the 2.2k $\Omega$  resistors and 'Voltage' configuration. .*

## B.8 Antennas

This section contains general information for interfaced GPS, GPS/WAAS, SXM, ADS-B, COM, and Marker Beacon antennas. This STC provides installation approval only for the Garmin glareshield-mounted GPS Antenna (011-04036-10 and 011-04036-00), refer to the *G3X Touch EFIS Part 23 AML STC Installation Manual* (190-02472-01) for installation guidance. All other antennas are approved as interface only and require separate installation approval.

A minimum of one GPS antenna is required for G3X installations as the connected GDU (PFD) will share GPS data with the second GDU (if installed). Additional GPS antennas may be used for redundancy but are not required.

**Table B-8 – Supported GPS & SXM Antennas**

Make & Model	P/N	Approved G3X Function	LRU Connection	Mounting
Comant 2480-201 (GPS/VHF Com)	CI 2480-201	GPS	GDU 4X0	Blade antenna, external
Garmin Glareshield GPS Antenna (TNC)	011-04036-00 (ordered as 010-12444-00)	GPS	GDU 4X0	Glareshield mounted via hook & loop or screws
Garmin Glareshield GPS Antenna (BNC)	011-04036-10 (ordered as 010-12444-10)	GPS	GDU 4X0	Glareshield mounted via hook & loop or screws
Garmin GA 56	011-00134-00 part of Kit 010-10040-01	GPS	GDU 4X0	Stud mount, teardrop, external
Garmin GA 37 (GPS/SXM)	013-00245-00	SXM	GDL 51R/52R	ARINC 743, external
Garmin GA 55	011-01033-00	SXM	GDL 51R/52R	Stud-mount, teardrop, external
Garmin GA 55A	011-01153-00	SXM	GDL 51R/52R	Through-mount, ARINC 743, external

The GPS antenna interface on the GDL 5XR is not used in this STC.

Only the SXM connection to the GA 37 antenna is approved in this STC. The GPS connection to the GA 37 is not compatible with any G3X LRUs but might be used for other installed equipment under their respective interface approvals.

Also note that if a previously installed G5 is connected to a GPS antenna mounted externally on the airframe, that antenna must be disconnected when the G5 is used as a standby instrument for G3X. It may be possible to repurpose the external antenna for other avionics if it is compatible under their respective interface approvals.

The GPS antenna should provide a gain of 16 to 25 dB. The GDU 4X0 supplies power to the antenna at 4.5-5.5 VDC with a maximum current of 50 mA.

The following information describes antenna performance requirements for proper system functionality.

**Table B-9 – GPS or GPS/WAAS Antenna Minimum Requirements**

Characteristics	Specifications
Frequency Range	1565 to 1585 MHz
Gain	16 to 25 dB typical, 40 dB max.
Noise Figure	<4.00 dB
Nominal Output Impedance	50Ω
Supply Voltage	4.5 to 5.5 VDC
Supply Current	up to 50 mA
Output Connector	BNC or TNC

**Table B-10 – SXM Satellite Radio Antenna Minimum Requirements**

Characteristics	Specifications
Frequency Range	2332.5 to 2345 MHz
Gain	24 dB*
Noise Figure	<1.2 dB
Nominal Output Impedance	50Ω
Supply Voltage	3.5 to 5.5 VDC
Supply Current	55 mA
Operating Temperature Gain	-50° to +85° C

\* - For each 1 dB gain over 24 dB, add 1 dB of attenuation into the antenna cable path between the antenna and the GDU.

### B.9 ADS-B Antenna Interface

The GDL 50R or GDL 52R requires an external monopole or blade-type ADS-B antenna for reception. The antenna should be mounted on the bottom of the aircraft and located at least 3.3 feet from high power transmitting antennas such as VHF Comm, HF transmitter, DME, Transponder, and Radar. The connection is made by attaching the coax cable from the external antenna to the BNC connector on the GDL 50R/52R. The GDL 50R/52R requires a UHF antenna that meets the following specifications:

- Standard 50 Ω vertically polarized antenna with a VSWR < 1.7:1 at 978 MHz and < 1.5:1 at 1090 MHz.
- TSO-C66, TSO-C74, or TSO-C112 antennas that also meet the VSWR specification.

### B.10 COM Antenna Interface

The GTR 20/200B requires an external COM antenna for reception. The COM antenna should be electrically bonded to a flat ground plane over as large an area as possible (at least 18 inches square). The antenna should be located at least 6 feet from other COM antennas, four feet from any ADF sense antennas, two feet from any GPS/SBAS antenna, and as far apart as practical from the ELT antenna for best performance. A configuration of one top-side antenna and one bottom-side antenna is recommended for dual COM installations. The GTR 20/200B requires a VHF antenna that meets the following specifications:

- Standard 50 Ω vertically polarized antenna.
- TSO-C37() and C38() or TSO-C169().

### **B.11 Marker Beacon Antenna Interface**

The GMA 245R may optionally be connected to an external marker beacon antenna for reception. The antenna must meet TSO-C35(). The marker beacon antenna should be mounted on a flat surface on the underside of the aircraft body.

The antenna should be located to minimize the amount of structure between it and the ground radio stations. It should be located as far away as possible from transmitter antennas.

In a composite aircraft, the antenna must have an acceptable ground plane. Conductive wire mesh, radials, or thin aluminum sheets embedded in the composite material provide the proper ground plane.